

PRECISION PLANETARY GEARBOXES

Catalogue



Index

2 TECHNICAL INFORMATION	139 TQFEK SERIES
3 1 General information	140 8 Features of TQFEK series
3 1.1 Symbols, units and definitions	141 8.1 Ordering code
5 1.2 Selecting the Gear unit	142 8.2 Dimensions and technical specifications
9 1.3 Service life of bearings	
11 TQ SERIES	148 SL SERIES
12 2 Features of TQ series	149 9 Features of SL series
13 2.1 Ordering code	150 9.1 Ordering code
14 2.2 Dimensions and technical specifications	151 9.2 Dimensions and technical specifications
24 TQK SERIES	163 LC SERIES
25 3 Features of TQK series	164 10 Features of LC series
26 3.1 Ordering code	165 10.1 Ordering code
27 3.2 Dimensions and technical specifications	166 10.2 Dimensions and technical specifications
37 TQF SERIES	182 LCK SERIES
38 4 Features of TQF series	183 11 Features of LCK series
39 4.1 Ordering code	184 11.1 Ordering code
40 4.2 Dimensions and technical specifications	185 11.2 Dimensions and technical specifications
50 TR SERIES	201 MPE SERIES
51 5 Features of TR series	202 12 Features of MPE series
53 5.1 Ordering code	203 12.1 Ordering code
54 5.1.1 Version and input section	204 12.2 Dimensions and technical specifications
54 5.1.2 Mounting position	
54 5.1.3 Admissible radial and axial forces for MB version	212 MPEK SERIES
55 5.2 Dimensions and technical specifications	213 13 Features of MPEK series
	214 13.1 Ordering code
90 MP SERIES	215 13.2 Dimensions and technical specifications
91 6 Features of MP series	221 KR SERIES
93 6.1 Ordering code	222 14 Features of KR series
94 6.1.1 Version and input section	223 14.1 Versions
94 6.1.2 Mounting position	223 14.2 Mounting position
94 6.1.3 Admissible radial and axial forces for MB version	223 14.3 Coordinated shaft rotation
95 6.2 Dimensions and technical specifications	224 14.4 Ordering code
129 6.2.1 Machine shaft	225 14.5 Technical specification
	226 14.6 Mass moment of inertia
130 TQFE SERIES	226 14.6.1 KR010..KR040 with standard ball bearings – SB
131 7 Features of TQFE series	227 14.6.2 KR020..KR040 with standard ball bearings – HB
132 7.1 Ordering code	228 14.7 Dimensions
133 7.2 Dimensions and technical specifications	236 14.7.1 Gearbox without motor adapter
	237 14.7.2 Machine shaft

**Technical
information**



1 GENERAL INFORMATION

1.1 SYMBOLS, UNITS AND DEFINITIONS

Values depending on the APPLICATION

term	u.m.	definition
A_2	[N]	Axial force on output shaft
A_2 EQU	[N]	Equivalent axial force applying on output shaft
A_2 MAX	[N]	Maximum axial force applying on output shaft
R_2	[N]	Radial force on output shaft
R_2 EQU	[N]	Equivalent radial force applying on output shaft
R_2 MAX	[N]	Maximum radial force applying on output shaft
ED	[s]	Duration of the duty (without brake)
ED%	[%]	Cyclic duration factor
L_{10h} TARGET	[h]	Output shaft bearings' desired basic rating life
M_1 PEAK	[Nm]	Maximum input torque (limited by motor control)
$M_{2(1)} \dots M_{2(n)}$	[Nm]	Output torque at the times $t_1 \dots t_n$
M_2 EQU	[Nm]	Equivalent output torque
M_2 MAX	[Nm]	Maximum output torque in case of emergency
M_{T2} EQU	[Nm]	Equivalent tilting moment applying on output shaft
M_{T2} MAX	[Nm]	Maximum permissible tilting moment applying on output shaft
n_1	[min ⁻¹]	Nominal input speed
n_2	[min ⁻¹]	Output speed
$n_{2(1)} \dots n_{2(n)}$	[min ⁻¹]	Output speed based on the times $t_1 \dots t_n$
n_2 EQU	[min ⁻¹]	Equivalent output speed
n_2 MAX	[min ⁻¹]	Maximum output speed
T	[C°]	Ambient temperature
$t_1 \dots t_n$	[s]	Operating time
t_Σ	[s]	Cycle duration including pause
Z	[1/h]	Number of cycles per hour

Values depending on the **GEAR DRIVE SELECTION**

term	u.m.	definition
$A_{2 \max} / A_{3 \max}$	[N]	Admissible axial force on output shaft
$A_{2 \max} / A_{3 \max}$	[N]	Axial force acting simultaneously with radial force
$R_{1 \max}$	[N]	Admissible radial force at midpoint of input shaft
$R_{2 \max} / R_{3 \max}$	[N]	Admissible radial force at midpoint of output shaft
C_B	[Nm]	Constant for bearing's lifetime calculation
C_t	$\left \frac{1}{\text{arcmin}} \right $	Torsional stiffness
f	—	Factor ratio between axial and radial force
f_n	—	Speed factor
f_z	—	Cycle factor
f_T	—	Temperature adjusting factor
i	—	Gearbox ratio
J_G	[kgcm ²]	Mass moment of inertia of the gearhead
K_n	—	Speed constant
L_{10h}	[h]	Bearings basic rating life
L_z	[mm]	Factor for bearing lifetime calculation
M_{a2}	[Nm]	Maximum acceleration output torque
M_{n2}	[Nm]	Rated output torque
M_{p2}	[Nm]	Emergency stop output torque. Permitted 1000 times during service life of the gearbox
$M_{T2 \max}$	[Nm]	Maximum tilting moment applying on output shaft
$n_{1 \max}$	[min ⁻¹]	Maximum momentary input speed. The speed the unit can be driven at occasionally and in non-repetitive conditions For duty type S5, it cannot be applied continuously for more than 30 seconds
p	—	Bearing lifetime exponent
η	[%]	Gear efficiency
ϕ_R	[arcmin]	Reduced backlash
ϕ_S	[arcmin]	Standard backlash

1.2 SELECTING THE GEAR UNIT

(a)	Ratio	i	—	$i = \frac{n_1}{n_2}$
(b)	Equivalent output torque	$M_{2\text{ EQU}}$	[Nm]	$M_{2\text{ EQU}} = \sqrt[3]{\frac{ n_{2(1)} \cdot t_1 \cdot M_{2(1)} ^3 + \dots + n_{2(n)} \cdot t_n \cdot M_{2(n)} ^3}{ n_{2(1)} \cdot t_1 + \dots + n_{2(n)} \cdot t_n}}$
(c)	Equivalent output speed	$n_{2\text{ EQU}}$	[min ⁻¹]	$n_{2\text{ EQU}} = \frac{ n_{2(1)} \cdot t_1 + n_{2(2)} \cdot t_2 + \dots + n_{2(n)} \cdot t_n}{t_\Sigma}$
(d)	Speed factor	f_n	—	<p>If $\frac{K_n}{n_{2\text{ EQU}} \cdot i} \geq 1 \Rightarrow f_n = 1$</p> <p>If $\frac{K_n}{n_{2\text{ EQU}} \cdot i} < 1 \Rightarrow f_n = \text{Obtain from diagram}$</p>
(e)	Temperature adjusting factor	f_T	—	
(f)	Cyclic duration factor	ED%	[%]	$ED\% = \frac{ED}{t_\Sigma} \cdot 100$
	Duration of the duty	ED	[s]	$ED = t_1 + t_2 + \dots + t_n$
(g)	Number of cycles per hour	Z	[1/h]	$Z = \frac{3600}{t_\Sigma}$
(h)	Cycle factor*	f_z	—	<p>*For Z>6000 please contact us!</p>
(i)	Maximum input torque	$M_{1\text{ PEAK}}$	[Nm]	maximum motor torque

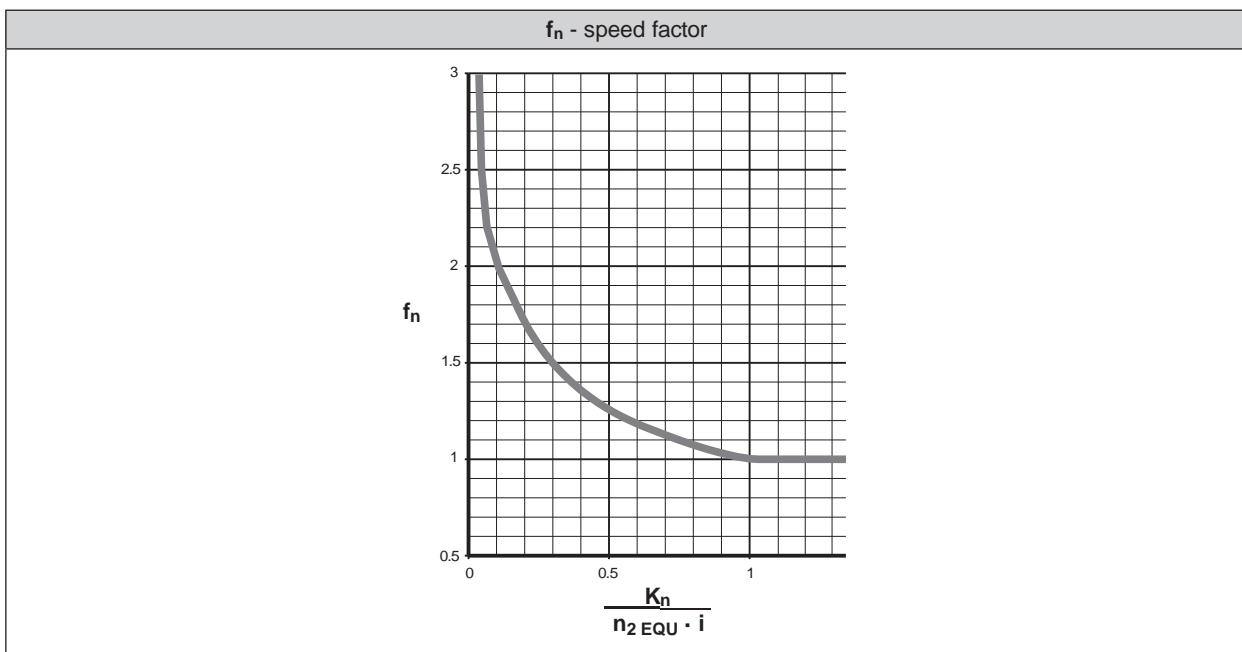

K_n - speed constant

i	TQ 060	TQ 070	TQ 090	TQ 130	TQ 160
3	3500	3100	1050	1800	1100
4	3500	3300	1050	2000	1450
5	3500	3500	1700	2500	1650
7	4000	3500	3000	2800	2500
10	4000	3500	3000	2800	2500
16	4500	3500	3000	2800	2500
20	4500	3500	3000	2800	2500
25	4500	3500	3000	2800	2500
28	4500	3500	3000	2800	2500
35	4500	3500	3000	2800	2500
40	4500	3500	3000	2800	2500
50	4500	3500	3500	3200	2500
70	5000	4500	4000	3500	2500
100	5000	4500	4000	3500	2500

i	TQK 060	TQK 070	TQK 090	TQK 130	TQK 160
6	2400	2400	2000	1600	1600
8	2400	2400	2000	1600	1600
10	2400	2400	2000	1600	1600
14	2400	2400	2000	1600	1600
18	2400	2400	2400	2000	1600
20	2400	2400	2400	1600	1600
24	2400	2400	2400	2000	1600
30	2400	2400	2400	2000	1600
40	2400	2400	2400	2000	1600
50	2400	2400	2400	2000	1600
70	2400	2400	2400	2000	1600
80	2400	2400	2400	2000	1600
100	2400	2400	2400	2000	1600
140	2400	2400	2400	2000	1600
200	2400	2400	2400	2000	1600

i	TQF 060	TQF 070	TQF 090	TQF 130	TQF 160
4	3500	3300	1050	2000	1450
5	3500	3500	1700	2500	1650
7	4000	3500	3000	2800	2500
10	4000	3500	3000	2800	2500
16	4500	3500	3000	2800	2500
20	4500	3500	3000	2800	2500
25	4500	3500	3000	2800	2500
28	4500	3500	3000	2800	2500
35	4500	3500	3000	2800	2500
40	4500	3500	3000	2800	2500
50	4500	3500	3500	3200	2500
70	5000	4500	4000	3500	2500
100	5000	4500	4000	3500	2500

i	TR / MP 053	TR / MP 060	TR / MP 080	TR / MP 105	TR / MP 130	TR / MP 160	TR / MP 190
3	1400	1400	2700	2500	1700	550	1500
4	2000	1600	1500	1600	500	350	1150
5	2300	2050	1750	1850	600	350	1300
6	2300	2500	2500	1050	150	150	1150
7	3800	3000	2100	1350	400	300	1600
9	4000	3300	2900	2500	2100	1600	1500
10	-	4000	4000	3500	3200	1150	2900
12	3300	3300	1500	1500	500	300	1050
15	3300	3300	1700	1750	600	350	1200
16	3500	3500	1950	2050	700	450	1400
20	3500	3500	2450	2550	850	300	1750
25	3500	3500	2800	2900	1000	350	2000
28	4000	4000	3450	3500	1200	450	2450
30	-	4000	4000	3500	3200	3000	1950
35	4000	4000	3950	3500	1350	500	2800
36	4000	3500	3200	1950	550	500	2300
40	-	4000	4000	3500	1700	650	2900
45	4000	-	-	-	-	-	-
48	4000	3500	3100	2800	2300	850	2100
50	-	4000	4000	3500	1950	750	2900
60	3500	-	-	-	-	-	-
64	3500	3500	3100	2800	2400	1000	2100
70	-	4000	4000	3500	2400	900	2900
75	3500	3500	3200	3000	2900	1350	2300
80	3500	3500	3100	2800	2400	1300	2100
81	4000	-	-	-	-	-	-
84	4000	4000	4000	3500	2900	1050	2900
90	-	4000	4000	3500	2850	3000	2900
100	3500	4000	4000	3500	3200	3000	2900
112	3500	-	-	-	-	-	-
120	-	4000	4000	3500	3200	2150	2900
125	3500	3500	3200	3000	2900	1800	2300
140	4000	4000	4000	3500	3200	2050	2900
144	4000	-	-	-	-	-	-
150	-	4000	4000	3500	3200	2200	2900
160	-	4000	4000	3500	3200	2550	2900
175	4000	4000	4000	3500	3200	2550	2900
180	4000	-	-	-	-	-	-
200	-	4000	4000	3500	3200	2900	2900
210	-	4000	4000	3500	3200	2700	2900
216	3500	3500	3200	3000	1900	-	-
225	4000	-	-	-	-	-	-
245	4000	-	-	-	-	-	-
250	-	4000	4000	3500	3200	3000	2900
252	4000	-	-	-	-	-	-
280	-	4000	4000	3500	3200	3000	2900
324	4000	-	-	-	-	-	-
350	-	4000	4000	3500	3200	3000	2900
400	-	4000	4000	3500	3200	3000	2900
405	4000	-	-	-	-	-	-
500	-	4000	4000	3500	3200	3000	2900
567	4000	-	-	-	-	-	-
700	-	4000	4000	3500	3200	3000	2900
729	4000	-	-	-	-	-	-
1000	-	4000	4000	3500	3200	3000	2900

K_n - speed constant

i	MPE 040	MPE 060 TQFE 060	MPE 080 TQFE 070	MPE 120 TQFE 090
3	2000	1400	3500	3000
4	2000	1600	2000	1700
5	2000	2050	1500	1500
7	3000	3050	1900	1900
9	2000	3300	3500	3000
10	3000	4000	3500	3500
12	3000	3300	3500	3000
15	3000	3300	3500	3000
16	3000	3500	3100	2800
20	3000	3500	3200	3000
25	3000	3500	3200	3000
28	3000	3700	3500	3500
30	3000	4000	4000	3500
35	3000	4000	3500	3000
40	3000	4000	4000	3500
50	3000	4000	4000	3500
70	3000	4000	4000	3500
100	3000	4000	4000	3500

i	MPEK 060 TQFEK 060	MPEK 080 TQFEK 070	MPEK 120 TQFEK 090
3	1400	3500	3000
4	1600	2000	1700
5	2050	1500	1500
7	3050	1900	1900
9	3300	3500	3000
10	4000	3500	3500
12	3300	3500	3000
15	3300	3500	3000
16	3500	3100	2800
20	3500	3200	3000
25	3500	3200	3000
28	3700	3500	3500
30	4000	4000	3500
35	4000	3500	3000
40	4000	4000	3500
50	4000	4000	3500
70	4000	4000	3500
100	4000	4000	3500

i	LC 050	LC 070 LC 070P	LC 090 / LC 090P	LC 120 / LC 120P	LC 155 / LC 155P
3	1650	1400	2900 / 3500	2500 / 3000	1350 / 2100
4	2200	1600	2500 / 2000	2100 / 1700	900 / 2200
5	2900	2050	2700 / 1500	2300 / 1500	950 / 800
7	3700	3050	3500 / 1900	3000 / 1900	1250
9	4000	3300	2900 / 3500	2500 / 3000	2100
10	-	4000	4000 / 3500	3500	2500 / 3200
12	3300	3300	2900 / 3500	2500 / 3000	2100
15	3300	3300	2900 / 3500	2500 / 3000	2100
16	3500	3500	3100	2800	2400
20	3500	3500	3200	3000	2900
25	3500	3500	3200	3000	2900
28	3500	3700	3500	3500	3000
30	-	4000	4000	3500	3000
35	3700	4000	3500	3000	3000
36	4000	-	-	-	-
40	-	4000	4000	3500	3000
45	4000	-	-	-	-
50	-	4000	4000	3500	3000
70	-	4000	4000	3500	3000
81	4000	-	-	-	-
100	-	4000	4000	3500	3000

i	SL 070 / SL 070P	SL 090 / SL 090P	SL 120 / SL 120P
3	1400	2900 / 3500	2500 / 3000
4	1600	2500 / 2000	2100 / 1700
5	2050	2700 / 1500	2300 / 1500
7	3050	3500 / 1900	3000 / 1900
9	3300	2900 / 3500	2500 / 3000
10	4000	4000 / 3500	3500
12	3300	2900 / 3500	2500 / 3000
15	3300	2900 / 3500	2500 / 3000
16	3500	3100	2800
20	3500	3200	3000
25	3500	3200	3000
28	3700	3500	3000
30	4000	4000	3500
35	4000	3500	3000
40	4000	4000	3500
50	4000	4000	3500
70	4000	4000	3500
100	4000	4000	3500

i	LCK 050	LCK 070 LCK 070P	LCK 090 LCK 090P	LCK 120 LCK 120P	LCK 155 LCK 155P
6	2400	2400	2400	2000	1600
8	2400	2400	2400	2000	1600
10	2400	2400	2400	2000	1600
14	2400	2400	2400	2000	1600
20	-	2400	2400	2000	1600
24	2400	2400	2400	2000	1600
30	2400	2400	2400	2000	1600
50	2400	2400	2400	2000	1600
70	2400	2400	2400	2000	1600
80	-	2400	2400	2000	1600
90	2400	-	-	-	-
100	-	2400	2400	2000	1600

i	KR 010	KR 020	KR 030	KR 040
1	1200	1200	1000	800
2	2400	2400	2000	1600
3	3000	3000	2800	2500

Load diagram

— M_2 : Output torque

Speed diagram

— n_2 : Output speed

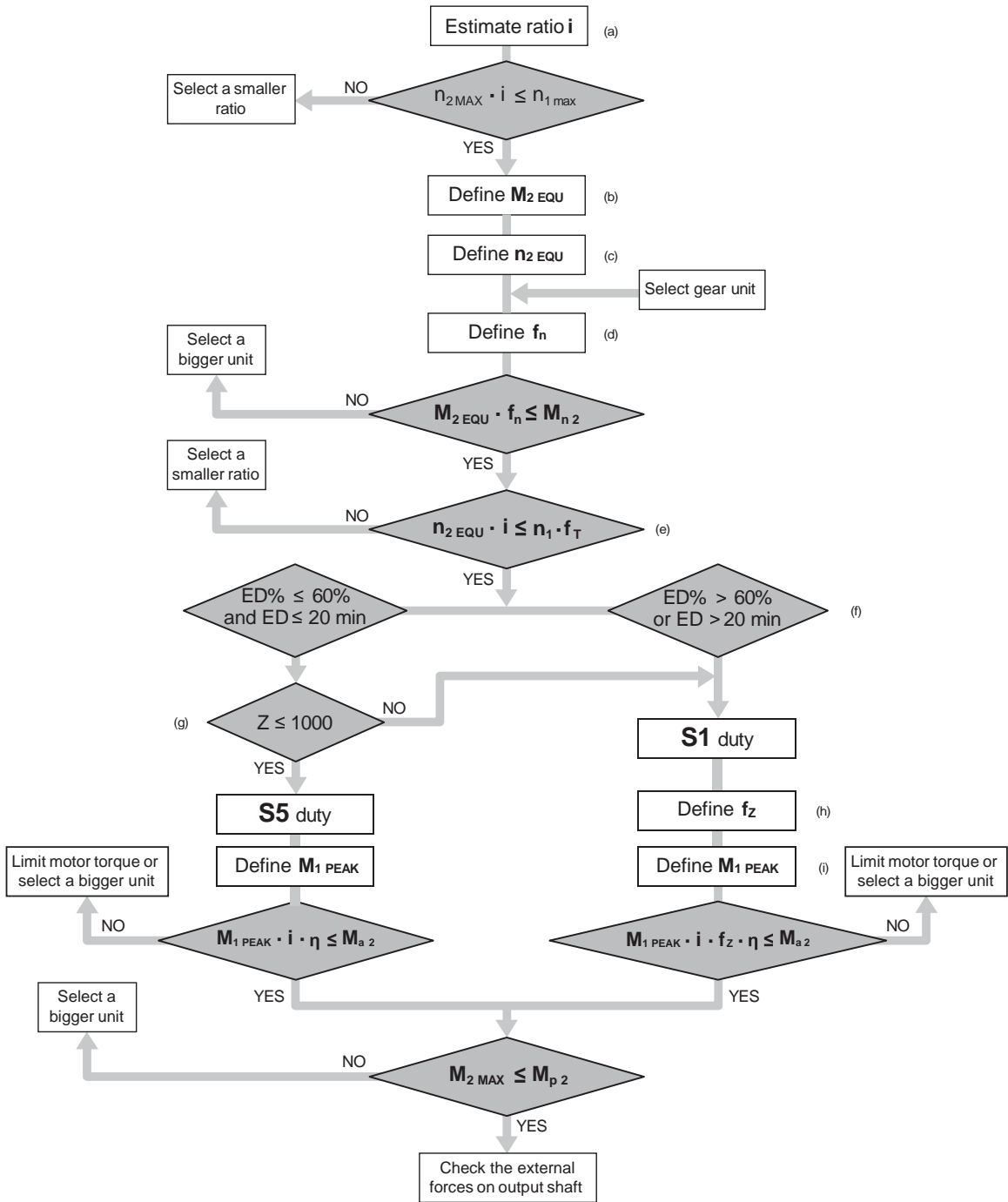
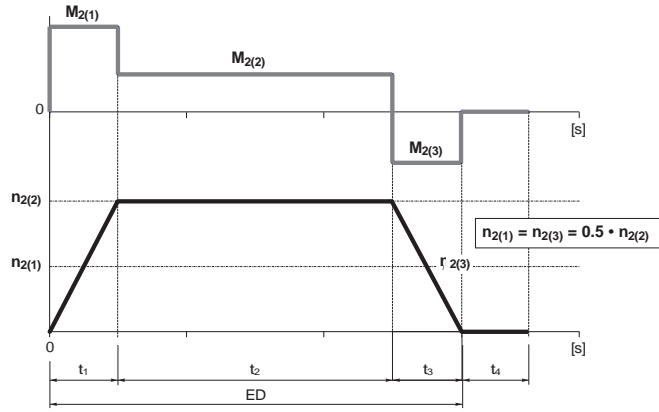

1.3 SERVICE LIFE OF BEARINGS

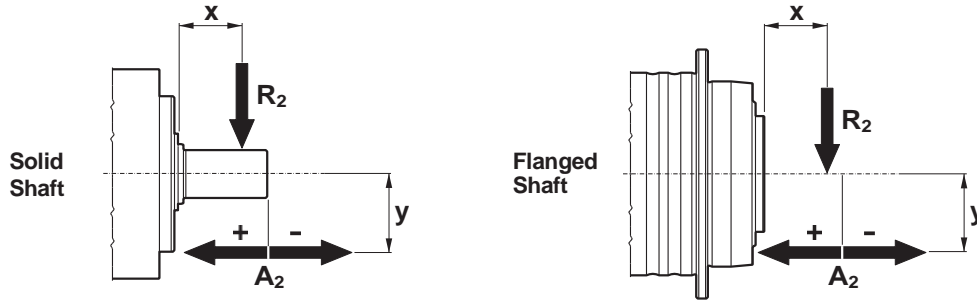

(a)	Maximum radial force applying on output shaft Maximum axial force applying on output shaft	$R_{2\text{MAX}}$ $A_{2\text{MAX}}$	[N] [N]	Please consider the specific conditions (e.g. belt drives under acceleration torque)
(b)	Maximum tilting moment applying on output shaft	$M_{T2\text{MAX}}$	[Nm]	$M_{T2\text{MAX}} = \frac{R_{2\text{MAX}} \cdot (x + L_z) \pm A_{2\text{MAX}} \cdot y}{1000}$
(c)	Equivalent forces applying on output shaft	$R_{2\text{EQU}}$ $A_{2\text{EQU}}$	[N] [N]	$R_{2\text{EQU}} = \sqrt[3]{\frac{ n_{2(1)} \cdot t_1 \cdot R_{2(1)} ^3 + \dots + n_{2(n)} \cdot t_n \cdot R_{2(n)} ^3}{ n_{2(1)} \cdot t_1 + \dots + n_{2(n)} \cdot t_n}}$ $A_{2\text{EQU}} = \sqrt[3]{\frac{ n_{2(1)} \cdot t_1 \cdot A_{2(1)} ^3 + \dots + n_{2(n)} \cdot t_n \cdot A_{2(n)} ^3}{ n_{2(1)} \cdot t_1 + \dots + n_{2(n)} \cdot t_n}}$
(d)	Equivalent tilting moment applying on output shaft	$M_{T2\text{EQU}}$	[Nm]	$M_{T2\text{EQU}} = \frac{R_{2\text{EQU}} \cdot (x + L_z) + A_{2\text{EQU}} \cdot y}{1000}$
(e)	Equivalent output speed	$n_{2\text{EQU}}$	[min ⁻¹]	$n_{2\text{EQU}} = \frac{ t_1 + n_{2(2)} \cdot t_2 + \dots + n_{2(n)} \cdot t_n }{t_1 + t_2 + \dots + t_n}$
(f)	Bearings' basic rating life	L_{10h}	[h]	$L_{10h} = \frac{16666}{n_{2\text{EQU}}} \cdot \left(\frac{C_B}{M_{T2\text{EQU}}} \right)^p$

	TQ / TQK 060		TQ / TQK 070		TQ / TQK 090		TQ / TQK 130	TQ / TQK 160
	SB	SB	SB	HB	SB	HB	SB	SB
L_z [mm]	56	67	64		95	89	96	114
$M_{T2\text{max}}$ [Nm]	129.5	221	343		592	772	1233	2331
C_B [Nm]	632	1065	1510		2898	3325	6395	9795
p	3	3	3.33		3	3.33	3.33	3.33

	TQF 060	TQF 070	TQF 090	TQF 130	TQF 160
	L_z [mm]	48	72	78	100
$M_{T2\text{max}}$ [Nm]	115	318	430	1200	3700
C_B [Nm]	490	1335	1815	5055	16200
p	3.33	3.33	3.33	3.33	3.33

	TR 053	TR 060	TR 080	TR 105	TR 130	TR 160	TR 190
	SB	SB	SB	SB	SB	SB	SB
L_z [mm]	22	23	42	53	74	94	100
$M_{T2\text{max}}$ [Nm]	16	23	155	278	515	739	1683
C_B [Nm]	91	143	994	2048	3893	5824	8680
p	3	3	3.33	3.33	3.33	3.33	3.33

	MP 053	MP 060	MP 080		MP 105		MP 130	MP 160	MP 190
	SB	SB	SB	HB	SB	HB	SB	SB	SB
L_z [mm]	22	23	44	42	46	53	74	94	100
$M_{T2\text{max}}$ [Nm]	16	23	83	155	99	278	515	739	1683
C_B [Nm]	91	143	407	994	637	2048	3893	5824	8680
p	3	3	3	3.33	3	3.33	3.33	3.33	3.33

	TQFE 060	TQFE 070	TQFE 090
	TQFEK 060	TQFEK 070	TQFEK 090
L_z [mm]	21	34	44
$M_{T2\text{max}}$ [Nm]	70	280	650
C_B [Nm]	14	57	125
p	3	3	3

	MPE 040	MPE 060	MPE 080	MPE 120
	MPEK 060	MPEK 080	MPEK 120	MPEK 120
L_z [mm]	16	23	31	37
$M_{T2\text{max}}$ [Nm]	6	17	44	124
C_B [Nm]	29	80	213	615
p	3	3	3	3

	LC / LCK 050	LC / LCK / SL 070	LC / LCK / SL 090	LC / LCK / SL 120	LC / LCK 155
	L_z [mm]	22	28	30	39
$M_{T2\text{max}}$ [Nm]	15	54	105	238	522
C_B [Nm]	106	280	298	813	1588
p	3	3	3	3	3

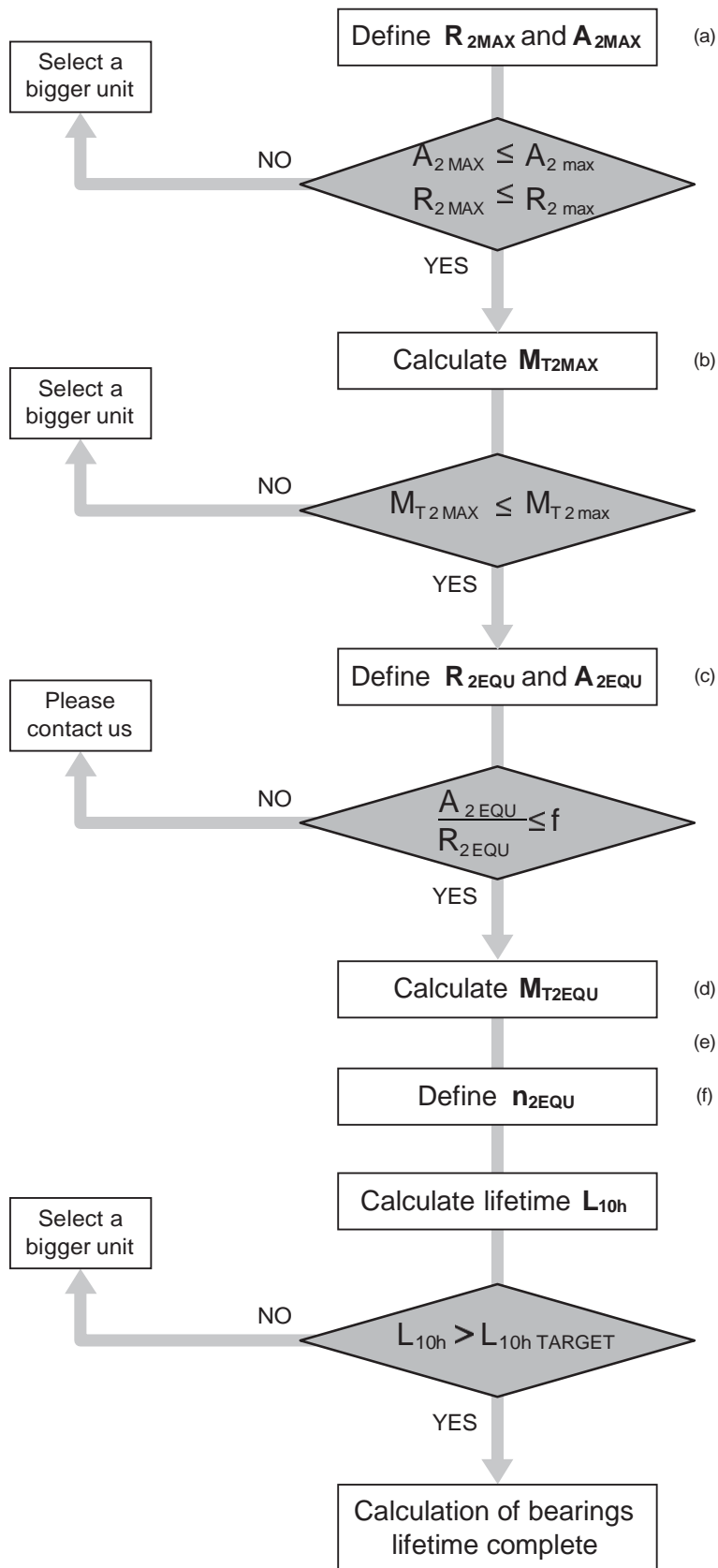

f	TQ TQK	TQF	TR	MP	TQFE TQFEK	SL	LC LCK	MPE	MPEK	KR
0.26	060 SB ... 090 SB		053 SB ... 060 SB	053 SB ... 105 SB	060 ... 090	070 ... 120	050 ... 155	040 ... 120	060 ... 120	010 SB ... 040 SB
0.37	130 SB ; 160 SB 070 HB ; 090 HB	060 ... 160	080 SB ... 190 SB	130 SB ... 190 SB 080 HB ; 105 HB						020 HB ... 040 HB



TQ Series

The TQ series scores in each performance category: high torque density, high overload capacity, exceptional precision and low vibration. TQ is particularly suited for the highly demanding requirements of servo systems, such as fast dynamics and frequent reverse motion, precise position, motion control and high numbers of starts and stops.

Main benefits

- Maximum power density
- High precision
- High overload capacity
- Optional reinforced bearings for high axial and radial forces
- Best choice for servo applications requiring high dynamics and high level of precision
- Great flexibility thanks to universal design
- Quiet operation

Main features

- Nominal output torque (Nm)

20 - 800

- Torsional backlash (arcmin)

2 - 6

- Torsional stiffness (Nm/arcmin)

4.7 - 170

- Max tilting moment (Nm)

129.5 - 2331

Protection class

- IP65

Frame sizes

- 060
- 070
- 090
- 130
- 160

Main options

- Input versions

MOTOR ADAPTER	WITHOUT MOTOR ADAPTER
- Output shafts versions

SMOOTH KEYLESS SHAFT	KEYED SHAFT
- Service type

S1	S5
- Lubrication

STANDARD LUBRICATION	FOOD GRADE LUBRICATION
- Bearings versions

STANDARD	REINFORCED

2 FEATURES OF TQ SERIES

Low backlash planetary drives of TQ series combine outstanding performances with a distinctive Italian style which makes them immediately recognizable amongst similar products within the reference industry.

Their design and construction has been developed with the goal of offering consumers a line of products which feature absolute and consistent Quality, which in turn provides a competitive advantage for machines and systems that adopt them as transmission devices.

TQ

- features two classes of precision, corresponding to the following values of torsional backlash
1-stage units: standard $\phi_S \leq 3'$ reduced $\phi_R \leq 2'$ ($\phi_S \leq 4'$; $\phi_R \leq 2'$ for TQ 060 and TQ 070)
2-stage units: standard $\phi_S \leq 5'$ reduced $\phi_R \leq 3'$ ($\phi_S \leq 6'$; $\phi_R \leq 4'$ for TQ 060 and TQ 070)
- high IP rating (IP65) provides inner parts with protection against the ingress of dust and liquids.
- section oil seals made from a Fluoroelastomer compound are supplied as standard.
- e pressure level $60 \leq L_p \leq 70$ dB(A). Conditions: distance 1 m ; measured without load and an input speed of $n_1 = 3000 \text{ min}^{-1}$; $i = 10$.
- s adapters allow matching the most popular brands of servomotors.
- n optimized for the type of duty specified when ordering.
In the absence of contamination the lubricant requires no periodical changes.

duty	TQ 060 ... TQ 160	output seals
S1 (continuous)	Synthetic oil viscosity ISO VG 220	Fluoroelastomer
S5 (intermittent)	NLGI grease consistency 00	NBR

- temperature min -20°C , max $+30^\circ\text{C}$. For temperature higher than 30°C please consider derating factor f_T .
- g temperature must not exceed $T_{\text{max}} = 90^\circ\text{C}$.

		Distribution of nominal torque M_{n2} [Nm]													
[i]		3	4	5	7	10	16	20	25	28	35	40	50	70	100
TQ 060		21	30	30	25	20	30	30	30	30	30	30	30	25	20
TQ 070		45	70	70	60	40	70	70	70	70	70	70	70	60	40
TQ 090		130	200	180	160	110	200	180	180	200	180	200	180	160	110
TQ 130		260	400	400	360	280	400	400	400	400	400	400	400	360	280
TQ 160		530	800	800	750	550	800	800	800	800	800	800	800	750	550

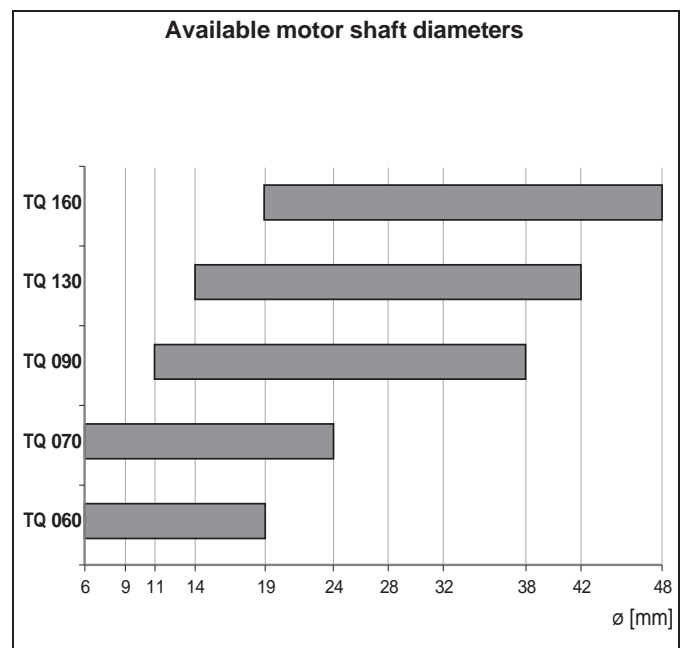
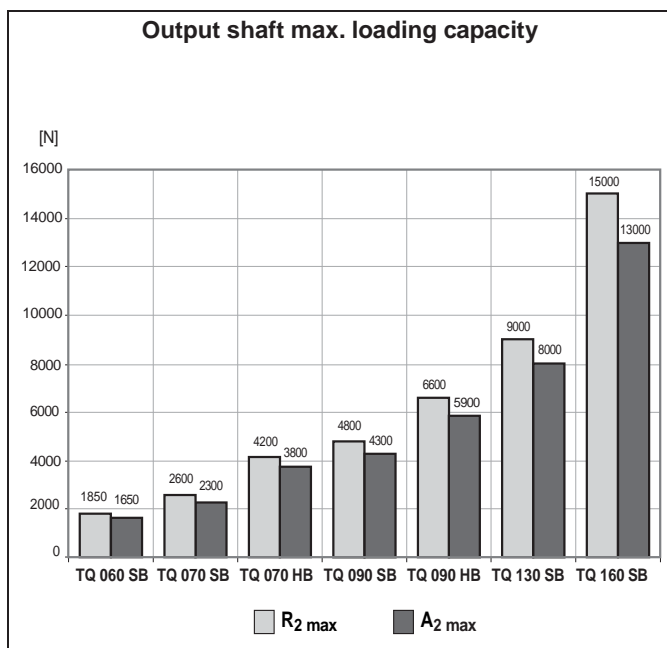

2.1 ORDERING CODE

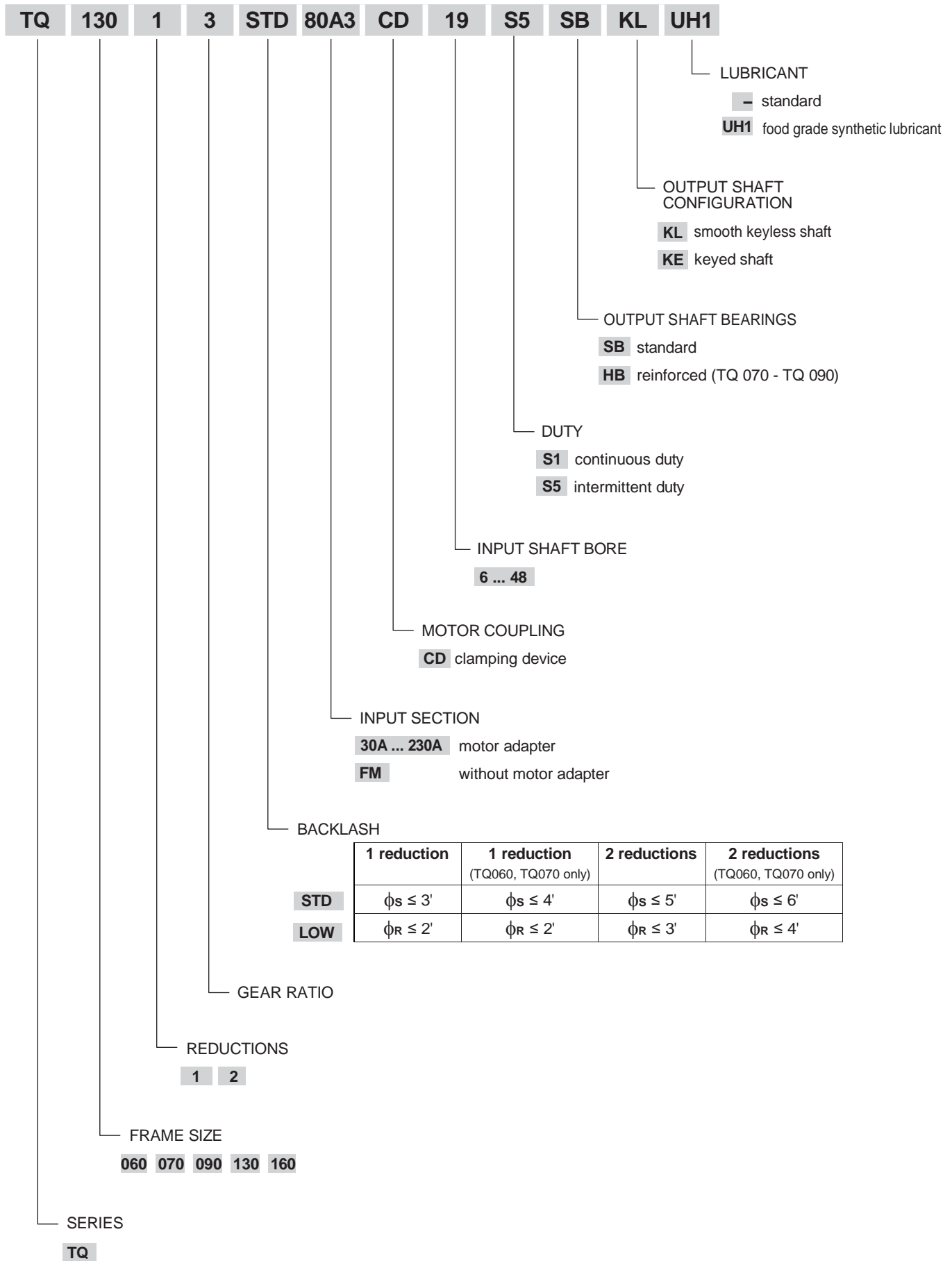

2.2 DIMENSIONS AND TECHNICAL SPECIFICATIONS

TQ 060

TQ

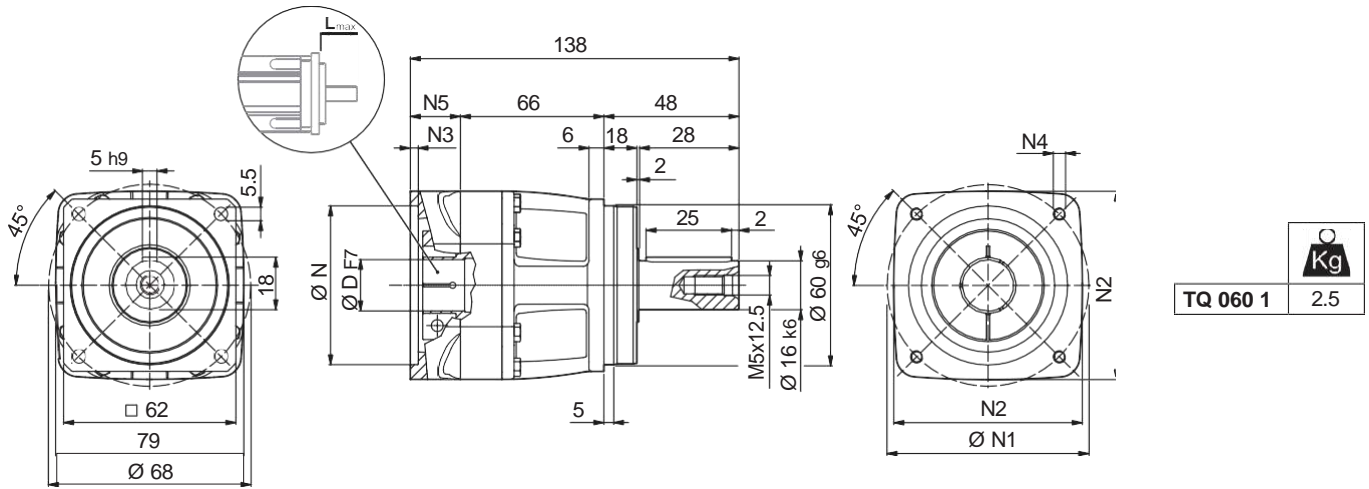

30A ... 110B0

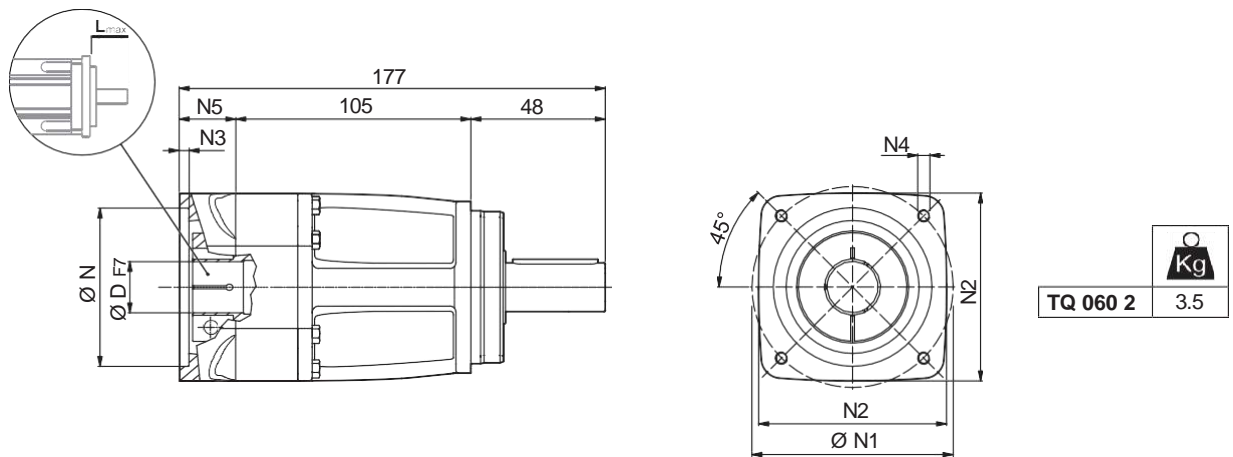

						N	N1	N2	N3	N4	N5	L _{max}
30A	6	-	-	-	-	30	46	80	3.5	M4x10	24	40
40B1	6	9	11	14	-	40	63	80	3.5	M4x10	24	40
50A1	6	9	11	14	-	50	60	80	4.0	M4x10	24	40
50C1	6	9	11	14	-	50	70	80	4.0	M4x10	24	40
60A2	6	9	11	14	19	60	75	80	4.0	M5x12	24	40
70B1	6	9	11	14	19	70	90	80	4.0	M5x12	24	40
80A1	6	9	11	14	19	80	100	100	4.0	M6x14	24	40
95A	6	9	11	14	19	95	115	100	4.0	M8x24	24	40
110B0	6	9	11	14	19	110	145	120	4.0	M8x24	24	40

Please contact us for different motor adapters and input shaft bore.

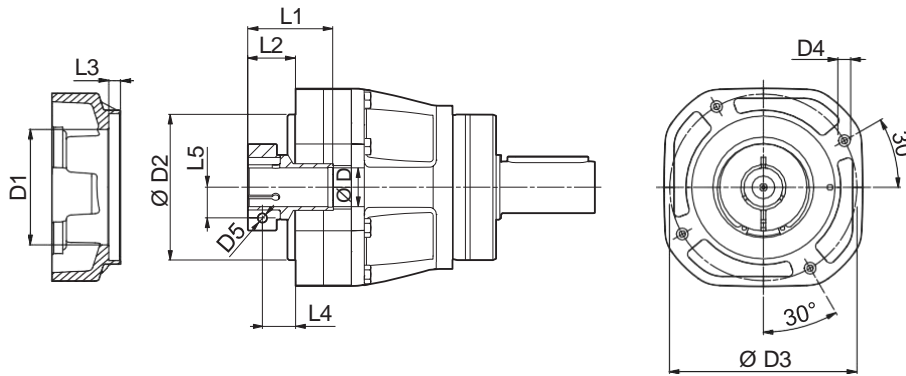

TQ 060

FM

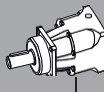

TQ

	D1	D2	D3	D4	D5	L1	L2	L3	L4	L5
6	37	59	72	M5x11	M4	31.5	15.5	4.5	10.5	8
9	49	59	72	M5x11	M5	35	19	4.5	11.5	10.5
11	49	59	72	M5x11	M6	35	19	4.5	11.5	12.5
14	49	59	72	M5x11	M6	35	19	4.5	11.5	14.5
19	54	59	72	M5x11	M6	35	19	4.5	11.5	16.5

	M_{n2} [Nm]	M_{a2} [Nm]	M_{p2} [Nm]	n_1 [min ⁻¹]	$n_{1\ max}$ [min ⁻¹]	$\phi_S \leq \phi_R$ [arcmin]		C_t $\frac{Nm}{arcmin}$	$R_{2\ max}$ [N]	$A_{2\ max}$ [N]	η %	J_G [kgcm ²] 		
						6 - 9	11 - 14					19		
TQ 060 1_3	21	32	60	3500	6000	4'	2'	4.8	1850	1650	97	0.36	0.47	0.51
TQ 060 1_4	30	45	80	3500	6000	4'	2'							
TQ 060 1_5	30	45	80	3500	6000	4'	2'	4.8	1850	1650	97	0.25	0.36	0.40
TQ 060 1_7	25	38	70	4000	6000	4'	2'	4.8	1850	1650	97	0.22	0.33	0.37
TQ 060 1_10	20	30	55	4000	6000	4'	2'	4.8	1850	1650	97	0.21	0.32	0.36
TQ 060 2_16	30	45	80	4500	6000	6'	4'	4.7	1850	1650	94	0.27	0.39	0.42
TQ 060 2_20	30	45	80	4500	6000	6'	4'	4.7	1850	1650	94	0.27	0.39	0.42
TQ 060 2_25	30	45	80	4500	6000	6'	4'	4.7	1850	1650	94	0.24	0.36	0.39
TQ 060 2_28	30	45	80	4500	6000	6'	4'	4.7	1850	1650	94	0.22	0.33	0.37
TQ 060 2_35	30	45	80	4500	6000	6'	4'	4.7	1850	1650	94	0.22	0.33	0.37
TQ 060 2_40	30	45	80	4500	6000	6'	4'	4.7	1850	1650	94	0.21	0.32	0.36
TQ 060 2_50	30	45	80	4500	6000	6'	4'	4.7	1850	1650	94	0.21	0.32	0.36
TQ 060 2_70	25	38	70	5000	6000	6'	4'	4.7	1850	1650	94	0.21	0.32	0.36
TQ 060 2_100	20	30	55	5000	6000	6'	4'	4.7	1850	1650	94	0.20	0.32	0.35

TQ 070

50C ... 130A

TQ

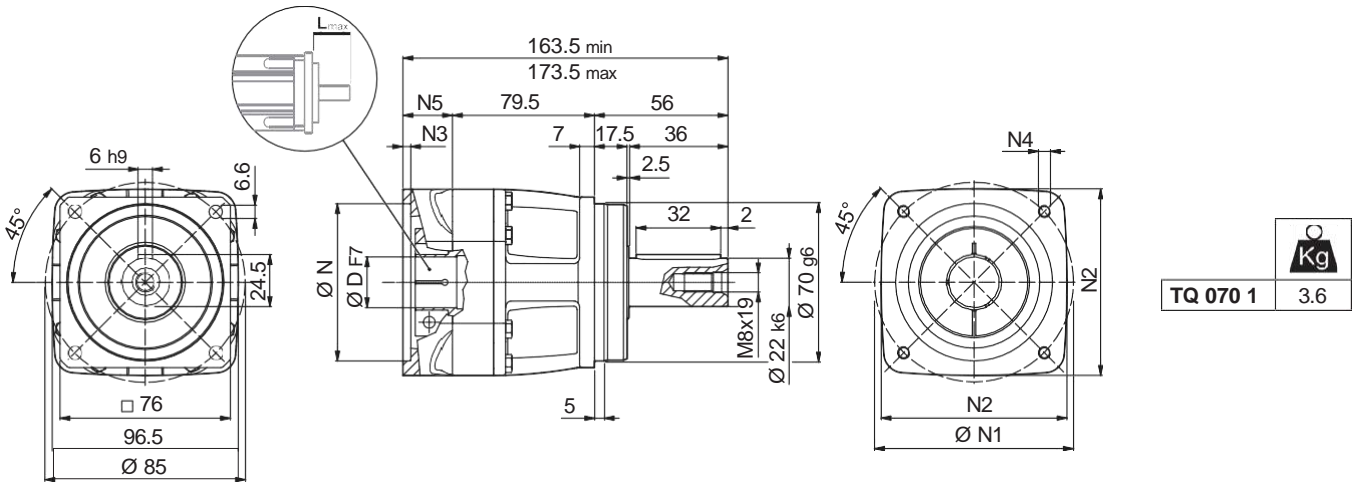

30A ... 110B0

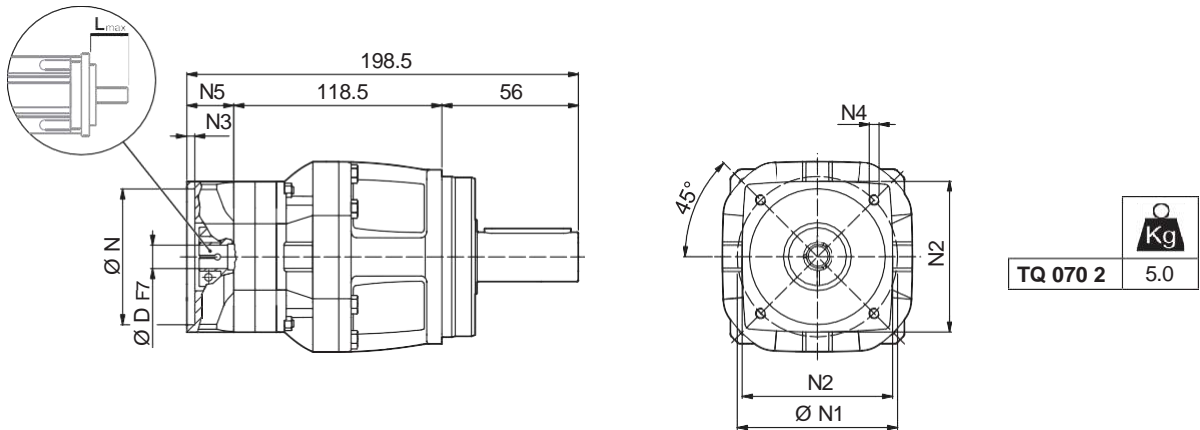

							N	N1	N2	N3	N4	N5	L _{max}
TQ 070 1													
50C2	6	9	11	14	–	–	50	70	100	6.5	M4x12	28	50
60A3	6	9	11	14	19	–	60	75	100	6.5	M5x14	28	50
70B2	6	9	11	14	19	–	70	90	100	6.5	M5x14	28	50
80A2	6	9	11	14	19	–	80	100	100	6.5	M6x14	28	50
95A1	6	9	11	14	19	24	95	115	100	6.5	M8x18	28	50
110A1	6	9	11	14	19	24	110	130	120	6.5	M8x18	28	50
110B1	6	9	11	14	19	24	110	145	120	6.5	M8x20	38	60
130A	6	9	11	14	19	24	130	165	140	6.5	M10x19	28	50
TQ 070 2													
30A	6	–	–	–	–	–	30	46	80	3.5	M4x10	24	40
40B1	6	9	11	14	–	–	40	63	80	3.5	M4x10	24	40
50A1	6	9	11	14	–	–	50	60	80	4.0	M4x10	24	40
50C1	6	9	11	14	–	–	50	70	80	4.0	M4x10	24	40
60A2	6	9	11	14	19	–	60	75	80	4.0	M5x12	24	40
70B1	6	9	11	14	19	–	70	90	80	4.0	M5x12	24	40
80A1	6	9	11	14	19	–	80	100	100	4.0	M6x14	24	40
95A	6	9	11	14	19	–	95	115	100	4.0	M8x24	24	40
110B0	6	9	11	14	19	–	110	145	120	4.0	M8x24	24	40

Please contact us for different motor adapters and input shaft bore.

TQ 070

FM

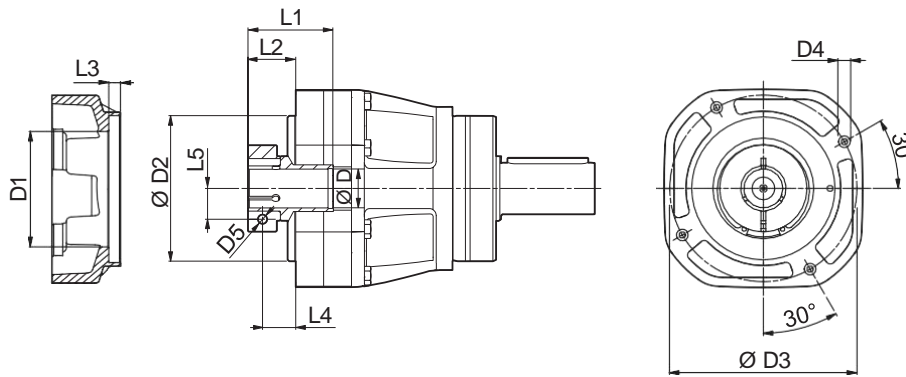

TQ

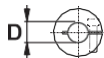
	D1	D2	D3	D4	D5	L1	L2	L3	L4	L5
TQ 070 1										
6	51	70	85	M6x11	M4	42	20	5	12.5	12.5
9	51	70	85	M6x11	M5	42	20	5	12.5	14.5
11	51	70	85	M6x11	M6	42	20	5	12.5	12.5
14	51	70	85	M6x11	M6	42	20	5	12.5	14.5
19	51	70	85	M6x11	M6	42	20	5	12.5	16.5
24	60	70	85	M6x11	M6	43.5	21.5	5	12.5	19
TQ 070 2										
6	37	59	72	M5x11	M4	31.5	15.5	4.5	10.5	8
9	49	59	72	M5x11	M5	35	19	4.5	11.5	10.5
11	49	59	72	M5x11	M6	35	19	4.5	11.5	12.5
14	49	59	72	M5x11	M6	35	19	4.5	11.5	14.5
19	54	59	72	M5x11	M6	35	19	4.5	11.5	16.5

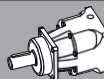
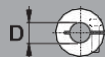
	M_{n2}	M_{a2}	M_{p2}	n_1	$n_{1\max}$	ϕ_S	ϕ_R	C_t	SB		HB		η	J_G [kgcm ²]			
									$R_{2\max}$	$A_{2\max}$	$R_{2\max}$	$A_{2\max}$					
i	[Nm]	[Nm]	[Nm]	[min ⁻¹]	[min ⁻¹]	[arcmin]	\leq	$\frac{Nm}{arcmin}$	[N]	[N]	[N]	[N]	%	6 - 9	11 - 14	19	24
TQ 070 1_3	45	65	120	3000	6000	4'	2'	11.3	2600	2300	4200	3800	97	-	0.99	1.02	1.15
TQ 070 1_4	70	100	180	3000	6000	4'	2'	11.3	2600	2300	4200	3800	97	-	0.76	0.79	0.92
TQ 070 1_5	70	100	180	3000	6000	4'	2'	11.3	2600	2300	4200	3800	97	-	0.67	0.70	0.83
TQ 070 1_7	60	90	160	3500	6000	4'	2'	11.3	2600	2300	4200	3800	97	-	0.59	0.62	0.75
TQ 070 1_10	40	60	110	3500	6000	4'	2'	11.3	2600	2300	4200	3800	97	-	0.55	0.58	0.71
TQ 070 2_16	70	100	180	3500	6000	6'	4'	11.3	2600	2300	4200	3800	94	0.28	0.40	0.43	-
TQ 070 2_20	70	100	180	3500	6000	6'	4'	11.3	2600	2300	4200	3800	94	0.28	0.39	0.43	-
TQ 070 2_25	70	100	180	3500	6000	6'	4'	11.3	2600	2300	4200	3800	94	0.25	0.36	0.40	-
TQ 070 2_28	70	100	180	3500	6000	6'	4'	11.3	2600	2300	4200	3800	94	0.22	0.34	0.37	-
TQ 070 2_35	70	100	180	3500	6000	6'	4'	11.3	2600	2300	4200	3800	94	0.22	0.34	0.37	-
TQ 070 2_40	70	100	180	3500	6000	6'	4'	11.3	2600	2300	4200	3800	94	0.21	0.32	0.36	-
TQ 070 2_50	70	100	180	3500	6000	6'	4'	11.3	2600	2300	4200	3800	94	0.21	0.32	0.36	-
TQ 070 2_70	60	90	160	4000	6000	6'	4'	11.3	2600	2300	4200	3800	94	0.21	0.32	0.36	-
TQ 070 2_100	40	60	110	4500	6000	6'	4'	11.3	2600	2300	4200	3800	94	0.21	0.32	0.36	-

TQ 090

60A4 ... 180A1

TQ

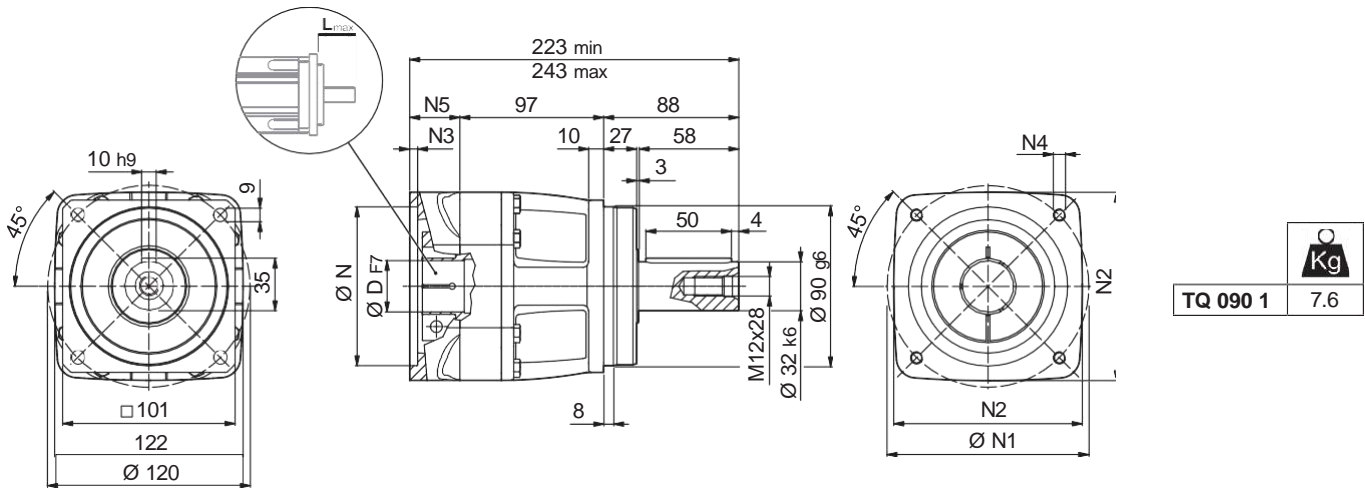

50C2 ... 130A

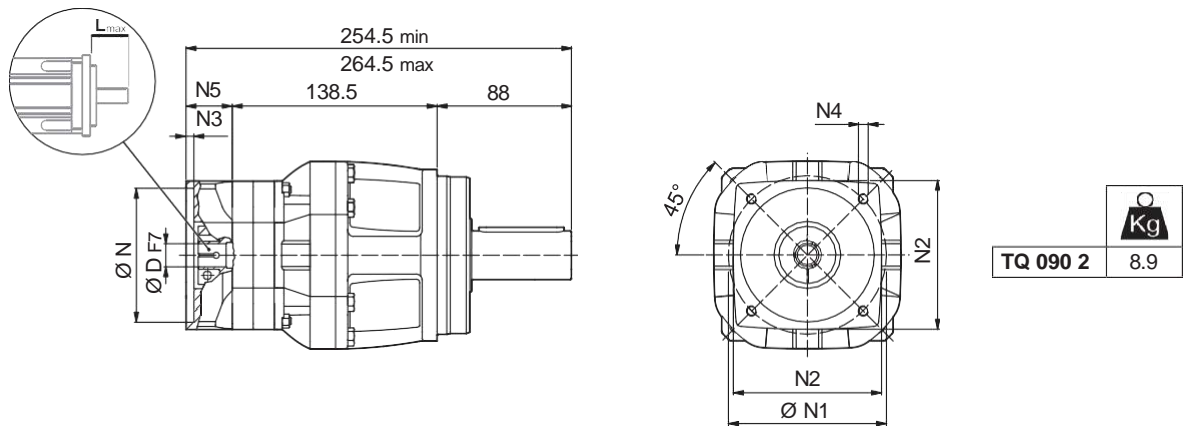

								N	N1	N2	N3	N4	N5	L _{max}
	D													
TQ 090 1														
60A4	11	14	19	-	-	-	-	60	75	125	6.5	M5x14	38	60
80A3	11	14	19	-	-	-	-	80	100	125	6.5	M6x14	38	60
95A2	11	14	19	24	28	-	-	95	115	125	6.5	M8x18	38	60
110A2	11	14	19	24	-	-	-	110	130	125	6.5	M8x20	38	60
110B1	11	14	19	24	28	-	-	110	145	125	6.5	M8x20	38	60
130A1	11	14	19	24	28	32	-	130	165	140	6.5	M10x20	38	60
180A	11	14	19	24	28	32	-	180	215	190	6.5	M14x38	38	60
180A1	11	14	19	24	28	32	38	180	215	190	6.5	M14x28	58	80
TQ 090 2														
50C2	11	14	-	-	-	-	-	50	70	100	6.5	M4x12	28	50
60A3	11	14	19	-	-	-	-	60	75	100	6.5	M5x14	28	50
70B2	11	14	19	-	-	-	-	70	90	100	6.5	M5x14	28	50
80A2	11	14	19	-	-	-	-	80	100	100	6.5	M6x14	28	50
95A1	11	14	19	24	-	-	-	95	115	100	6.5	M8x18	28	50
110A1	11	14	19	24	-	-	-	110	130	120	6.5	M8x18	28	50
110B1	11	14	19	24	-	-	-	110	145	120	6.5	M8x20	38	60
130A	11	14	19	24	-	-	-	130	165	140	6.5	M10x19	28	50

Please contact us for different motor adapters and input shaft bore.

TQ 090

FM

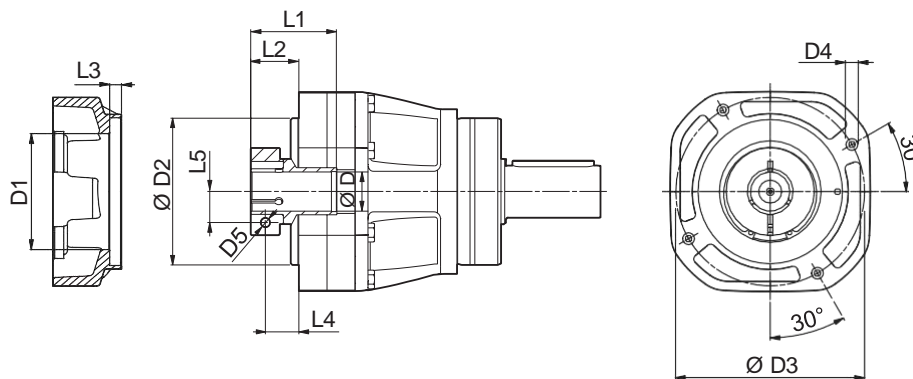

TQ

	D1	D2	D3	D4	D5	L1	L2	L3	L4	L5
TQ 090 1										
11	51	90	115	M8x13	M6	50	28	6.5	20.5	14.5
14	51	90	115	M8x13	M6	50	28	6.5	20.5	14.5
19	51	90	115	M8x13	M6	50	28	6.5	20.5	16.5
24	60	90	115	M8x13	M6	51.5	29.5	6.5	20.5	19
28	72	90	115	M8x13	M8	51.5	29.5	6.5	20.5	22.5
32	72	90	115	M8x13	M8	51.5	29.5	6.5	20.5	24.5
38	80	90	115	M8x13	M8	51.5	32	6.5	20.5	28
TQ 090 2										
6	51	70	85	M6x11	M6	42	20	5	12.5	12.5
9	51	70	85	M6x11	M5	42	20	5	12.5	14.5
11	51	70	85	M6x11	M6	42	20	5	12.5	12.5
14	51	70	85	M6x11	M6	42	20	5	12.5	14.5
19	51	70	85	M6x11	M6	42	20	5	12.5	16.5
24	60	70	85	M6x11	M6	43.5	21.5	5	12.5	19

	i	M _{n2} [Nm]	M _{a2} [Nm]	M _{p2} [Nm]	n ₁ [min ⁻¹]	n _{1 max} [min ⁻¹]	ϕ		C _t Nm arcmin	SB		HB		η	J _e [kgcm ²]				
							≤	≤		R _{2 max} [N]	A _{2 max} [N]	R _{2 max} [N]	A _{2 max} [N]						
															11	14 - 19	24	28	32-38
TQ 090 1_3		130	200	400	2500	4500	3'	2'	28	4800	4300	6600	5900	97	-	2.18	2.30	2.69	4.48
TQ 090 1_4		200	300	500	2500	4500	3'	2'	28	4800	4300	6600	5900	97	-	1.63	1.75	2.14	3.93
TQ 090 1_5		180	280	500	2500	4500	3'	2'	28	4800	4300	6600	5900	97	-	1.39	1.52	1.90	3.70
TQ 090 1_7		160	250	500	3000	4500	3'	2'	28	4800	4300	6600	5900	97	-	1.19	1.32	1.70	3.50
TQ 090 1_10		110	170	350	3000	4500	3'	2'	28	4800	4300	6600	5900	97	-	1.08	1.21	1.59	3.39
TQ 090 2_16		200	300	500	3000	4500	5'	3'	28	4800	4300	6600	5900	94	0.70	0.80	0.94	-	-
TQ 090 2_20		180	280	500	3000	4500	5'	3'	28	4800	4300	6600	5900	94	0.69	0.79	0.92	-	-
TQ 090 2_25		180	280	500	3000	4500	5'	3'	28	4800	4300	6600	5900	94	0.60	0.70	0.83	-	-
TQ 090 2_28		200	300	500	3000	4500	5'	3'	28	4800	4300	6600	5900	94	0.53	0.63	0.76	-	-
TQ 090 2_35		180	280	500	3000	4500	5'	3'	28	4800	4300	6600	5900	94	0.52	0.62	0.75	-	-
TQ 090 2_40		200	300	500	3000	4500	5'	3'	28	4800	4300	6600	5900	94	0.48	0.58	0.71	-	-
TQ 090 2_50		180	280	500	3500	4500	5'	3'	28	4800	4300	6600	5900	94	0.48	0.58	0.71	-	-
TQ 090 2_70		160	250	500	4000	4500	5'	3'	28	4800	4300	6600	5900	94	0.48	0.58	0.71	-	-
TQ 090 2_100		110	170	350	4000	4500	5'	3'	28	4800	4300	6600	5900	94	0.48	0.58	0.71	-	-

TQ 130

80A3 ... 200A

TQ

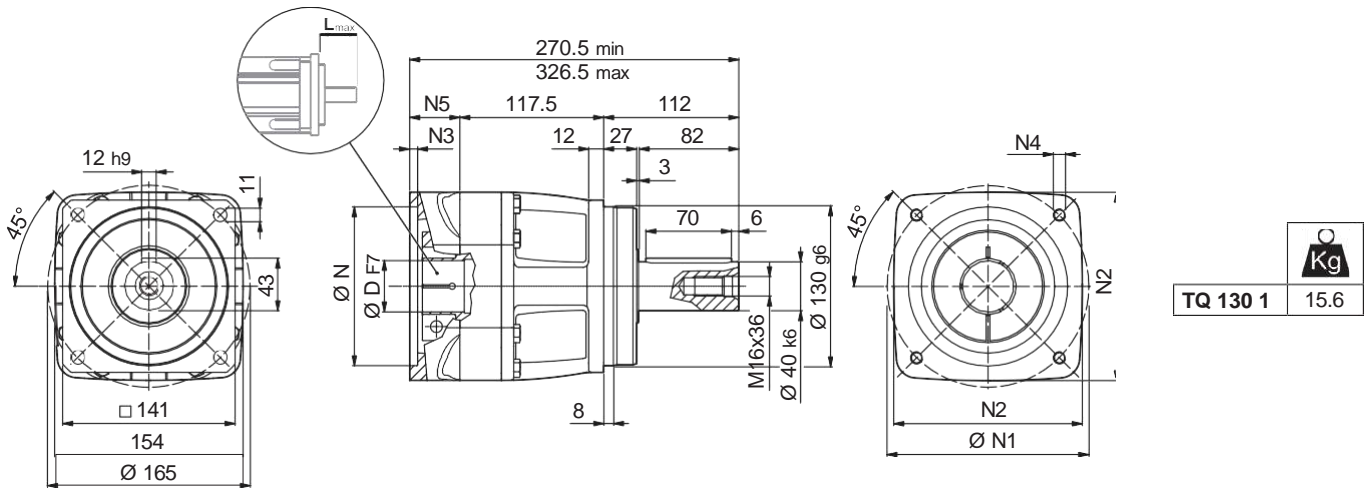

60A4 ... 180A1

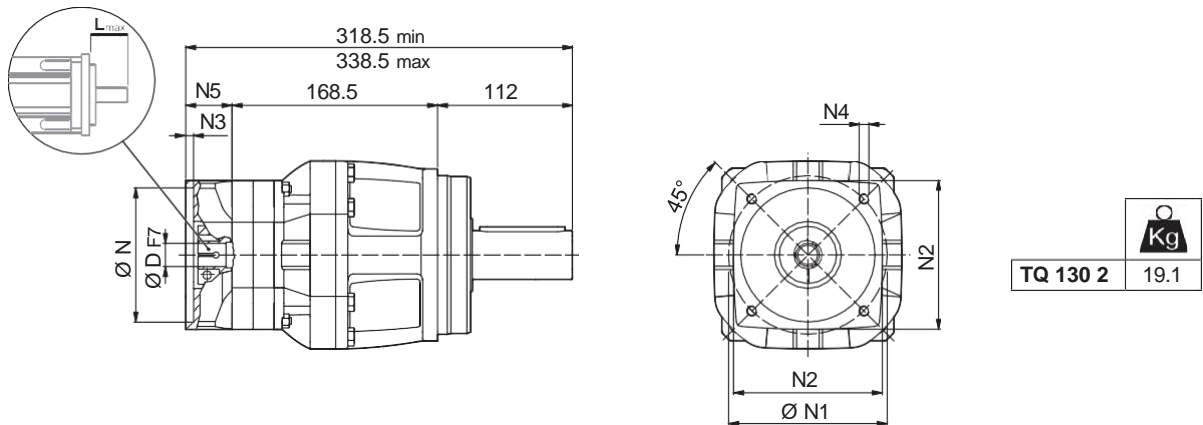

								N	N1	N2	N3	N4	N5	L _{max}
TQ 130 1														
80A3	14	19	-	-	-	-	-	80	100	155	6.5	M6x14	41	60
95A2	14	19	24	28	-	-	-	95	115	155	6.5	M8x18	41	60
110A2	14	19	24	-	-	-	-	110	130	155	6.5	M8x20	41	60
110B1	14	19	24	28	-	-	-	110	145	155	6.5	M8x20	41	60
130A1	14	19	24	28	32	-	-	130	165	155	6.5	M10x20	41	60
180A	14	19	24	28	32	-	-	180	215	190	6.5	M14x28	41	60
180A1	14	19	24	28	32	38	-	180	215	190	6.5	M14x28	61	80
200A	14	19	24	28	32	38	42	200	235	220	6.5	M14x28	97	110
TQ 130 2														
60A4	14	19	-	-	-	-	-	60	75	125	6.5	M5x14	38	60
80A3	14	19	-	-	-	-	-	80	100	125	6.5	M6x14	38	60
95A2	14	19	24	28	-	-	-	95	115	125	6.5	M8x18	38	60
110A2	14	19	24	-	-	-	-	110	130	125	6.5	M8x20	38	60
110B1	14	19	24	28	-	-	-	110	145	125	6.5	M8x20	38	60
130A1	14	19	24	28	32	-	-	130	165	140	6.5	M10x20	38	60
180A	14	19	24	28	32	-	-	180	215	190	6.5	M14x38	38	60
180A1	14	19	24	28	32	38	-	180	215	190	6.5	M14x28	58	80

Please contact us for different motor adapters and input shaft bore.

TQ 130

FM

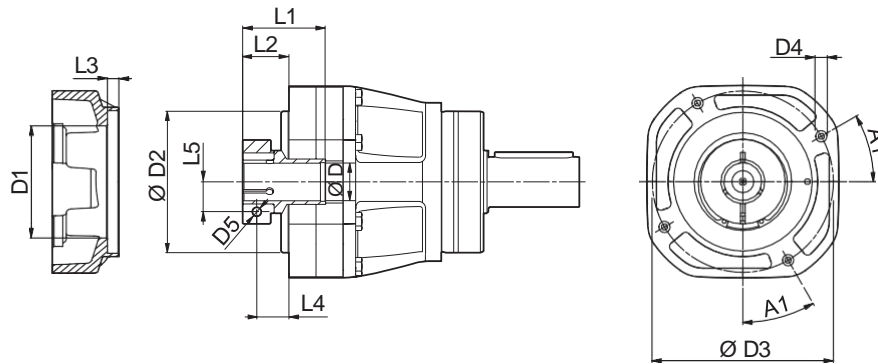

TQ

	A1	D1	D2	D3	D4	D5	L1	L2	L3	L4	L5
TQ 130 1											
14	22°	54	120	140	M10x16	M6	50	31	7.5	23.5	16.5
19	22°	54	120	140	M10x16	M6	50	31	7.5	23.5	16.5
24	22°	70	120	140	M10x16	M6	51.5	32.5	7.5	23.5	19
28	22°	70	120	140	M10x16	M8	51.5	32.5	7.5	23.5	22.5
32	22°	72	120	140	M10x16	M8	51.5	32.5	7.5	23.5	24.5
38	22°	100	120	140	M10x16	M8	54	35	7.5	23.5	28
42	22°	114	120	140	M10x16	M10	51.5	38.5	7.5	23.5	33
TQ 130 2											
11	30°	51	90	115	M8x13	M6	50	28	6.5	20.5	14.5
14	30°	51	90	115	M8x13	M6	50	28	6.5	20.5	14.5
19	30°	51	90	115	M8x13	M6	50	28	6.5	20.5	16.5
24	30°	60	90	115	M8x13	M6	51.5	29.5	6.5	20.5	19
28	30°	72	90	115	M8x13	M8	51.5	29.5	6.5	20.5	22.5
32	30°	72	90	115	M8x13	M8	51.5	29.5	6.5	20.5	24.5
38	30°	80	90	115	M8x13	M8	51.5	32	6.5	20.5	28

	i	M _{n2}	M _{a2}	M _{p2}	n ₁	n _{1 max}	φ _S	φ _R	C _t	R _{2 max}	A _{2 max}	η	J _G [kgcm ²]				
		[Nm]	[Nm]	[Nm]	[min ⁻¹]	[min ⁻¹]	≤	arcmin	$\frac{Nm}{arcmin}$	[N]	[N]	%	14	19 - 24	28 - 32	38	42
TQ 130 1_3		260	400	900	2100	4000	3'	2'	59	9000	8000	97	-	10.02	10.48	11.12	17.12
TQ 130 1_4		400	600	1000	2100	4000	3'	2'	59	9000	8000	97	-	6.38	6.85	7.49	13.49
TQ 130 1_5		400	600	1000	2500	4000	3'	2'	59	9000	8000	97	-	5.01	5.47	6.11	12.11
TQ 130 1_7		360	550	950	2500	4000	3'	2'	59	9000	8000	97	-	3.82	4.28	4.93	10.93
TQ 130 1_10		280	420	900	2500	4000	3'	2'	59	9000	8000	97	-	3.15	3.61	4.25	10.25
TQ 130 2_16		400	600	1000	2800	4000	5'	3'	58	9000	8000	94	1.72	1.87	3.53	4.05	-
TQ 130 2_20		400	600	1000	2800	4000	5'	3'	58	9000	8000	94	1.64	1.80	3.46	3.98	-
TQ 130 2_25		400	600	1000	2800	4000	5'	3'	58	9000	8000	94	1.39	1.55	3.21	3.73	-
TQ 130 2_28		400	600	1000	2800	4000	5'	3'	58	9000	8000	94	1.20	1.36	3.02	3.54	-
TQ 130 2_35		400	600	1000	2800	4000	5'	3'	58	9000	8000	94	1.17	1.33	2.99	3.51	-
TQ 130 2_40		400	600	1000	3200	4000	5'	3'	58	9000	8000	94	1.07	1.23	2.89	3.41	-
TQ 130 2_50		400	600	1000	3200	4000	5'	3'	58	9000	8000	94	1.06	1.21	2.87	3.39	-
TQ 130 2_70		360	550	950	3500	4000	5'	3'	58	9000	8000	94	1.05	1.20	2.86	3.38	-
TQ 130 2_100		280	420	900	4000	4000	5'	3'	58	9000	8000	94	1.04	1.20	2.86	3.38	-

TQ 160

95A2 ... 230A

TQ

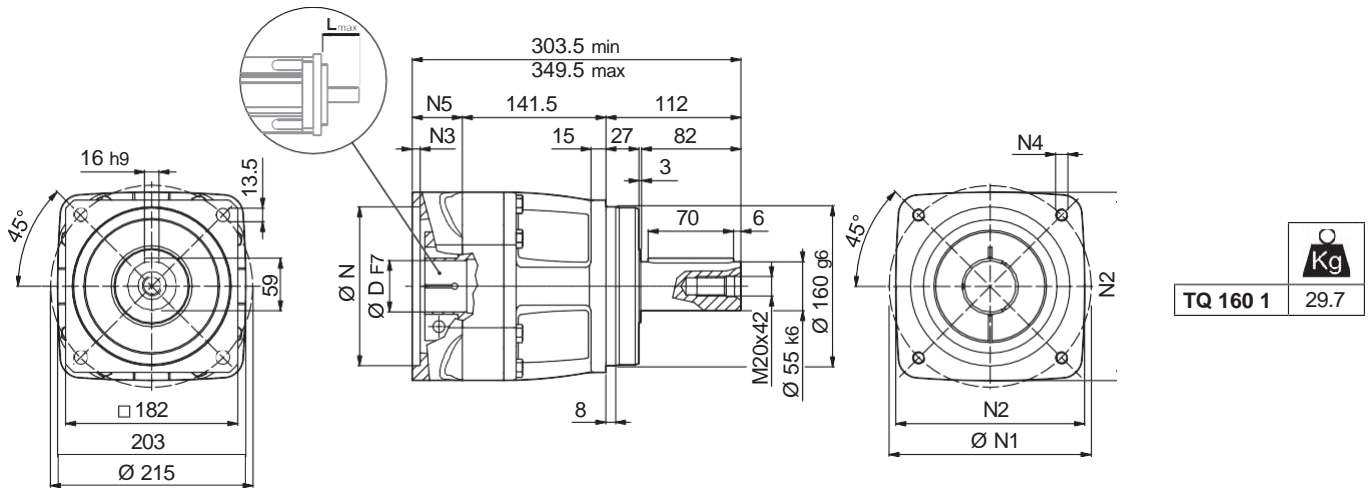

80A3 ... 200A

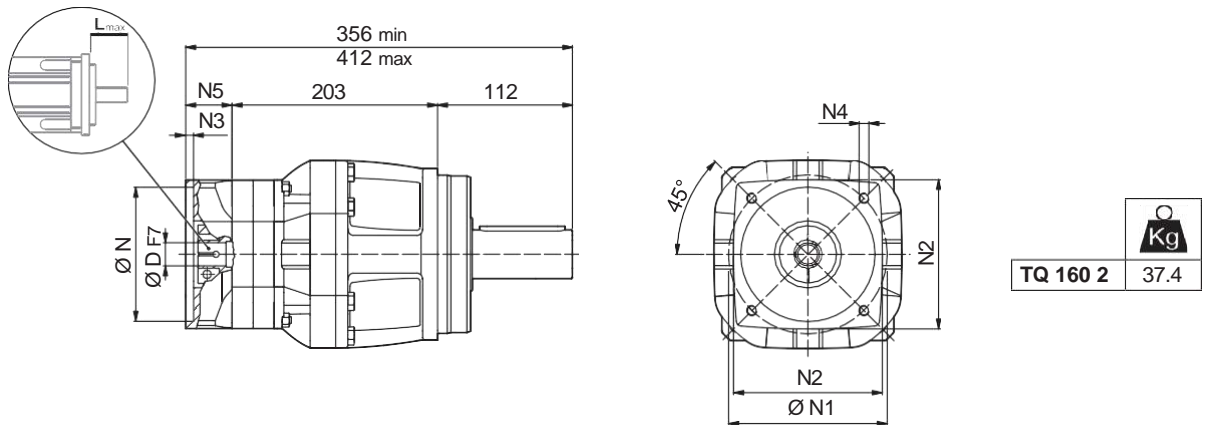

								N	N1	N2	N3	N4	N5	L _{max}
TQ 160 1														
95A2	19	24	28	-	-	-	-	95	115	205	6.5	M8x20	50	60
110A2	19	24	-	-	-	-	-	110	130	205	6.5	M8x20	50	60
130A1	19	24	28	32	-	-	-	130	165	205	6.5	M10x20	50	60
180A	19	24	28	32	-	-	-	180	215	205	6.5	M14x28	50	60
180A1	19	24	28	32	38	-	-	180	215	205	6.5	M14x28	60	80
200A	19	24	28	32	38	42	48	200	235	220	6.5	M14x28	96	110
230A	19	24	28	32	38	42	48	230	265	240	6.5	M14x28	96	110
TQ 160 2														
80A3	19	-	-	-	-	-	-	80	100	155	6.5	M6x14	41	60
95A2	19	24	28	-	-	-	-	95	115	155	6.5	M8x18	41	60
110A2	19	24	-	-	-	-	-	110	130	155	6.5	M8x20	41	60
110B1	19	24	28	-	-	-	-	110	145	155	6.5	M8x20	41	60
130A1	19	24	28	32	-	-	-	130	165	155	6.5	M10x20	41	60
180A	19	24	28	32	-	-	-	180	215	190	6.5	M14x28	41	60
180A1	19	24	28	32	38	-	-	180	215	190	6.5	M14x28	61	80
200A	19	24	28	32	38	42	-	200	235	220	6.5	M14x28	97	110

Please contact us for different motor adapters and input shaft bore.

TQ 160

FM

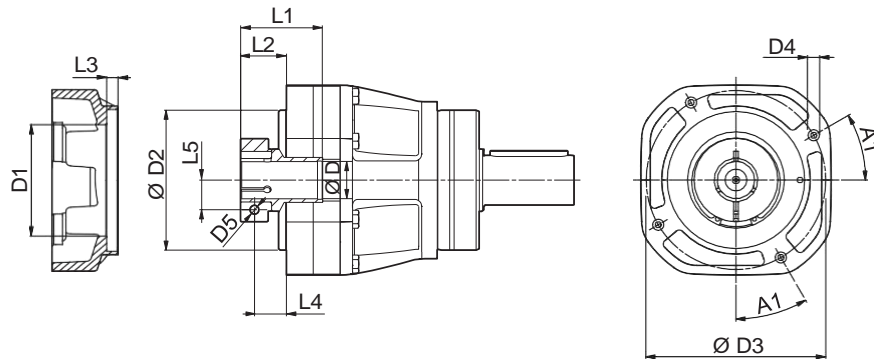

TQ

	A1	D1	D2	D3	D4	D5	L1	L2	L3	L4	L5
TQ 160 1											
19	30°	58	150	175	M12x20	M6	47	37	9.5	28	19
24	30°	58	150	175	M12x20	M6	47	37	9.5	28	19
28	30°	70	150	175	M12x20	M8	47	37	9.5	28	22.5
32	30°	72	150	175	M12x20	M8	47	37	9.5	28	24.5
38	30°	100	150	175	M12x20	M8	59.5	39.5	9.5	28	28
42	30°	114	150	175	M12x20	M10	57	43	9.5	28	33
48	30°	125	150	175	M12x20	M12	57	43	9.5	28	36.5
TQ 160 2											
14	22°	54	120	140	M10x16	M6	50	31	7.5	23.5	16.5
19	22°	54	120	140	M10x16	M6	50	31	7.5	23.5	16.5
24	22°	70	120	140	M10x16	M6	51.5	32.5	7.5	23.5	19
28	22°	70	120	140	M10x16	M8	51.5	32.5	7.5	23.5	22.5
32	22°	72	120	140	M10x16	M8	51.5	32.5	7.5	23.5	24.5
38	22°	100	120	140	M10x16	M8	54	35	7.5	23.5	28
42	22°	114	120	140	M10x16	M10	51.5	38.5	7.5	23.5	33

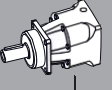
	M_{n2}	M_{a2}	M_{p2}	n_1	$n_{1\max}$	$\phi_S \leq \phi_R$		C_t	$R_{2\max}$	$A_{2\max}$	η	J_G [kgcm ²]				
						$\frac{Nm}{arcmin}$	[N]					[N]	%	19	24 - 28	32 - 38
TQ 160 1_3	530	800	1500	1500	3500	3'	2'	170	15000	13000	97	-	29.58	29.99	32.89	45.99
TQ 160 1_4	800	1200	2000	1500	3500	3'	2'	170	15000	13000	97	-	18.03	18.44	21.33	34.44
TQ 160 1_5	800	1200	2000	1800	3500	3'	2'	170	15000	13000	97	-	11.76	12.17	15.06	28.17
TQ 160 1_7	750	1150	2000	2500	3500	3'	2'	170	15000	13000	97	-	9.27	9.68	12.58	25.68
TQ 160 1_10	550	850	1600	2500	3500	3'	2'	170	15000	13000	97	-	7.05	7.46	10.35	23.46
TQ 160 2_16	800	1200	2000	2800	3500	5'	3'	170	15000	13000	94	6.52	7.05	7.77	13.77	-
TQ 160 2_20	800	1200	2000	2800	3500	5'	3'	170	15000	13000	94	6.16	6.69	7.41	13.41	-
TQ 160 2_25	800	1200	2000	2800	3500	5'	3'	170	15000	13000	94	4.81	5.34	6.06	12.06	-
TQ 160 2_28	800	1200	2000	2800	3500	5'	3'	170	15000	13000	94	3.77	4.30	5.02	11.02	-
TQ 160 2_35	800	1200	2000	2800	3500	5'	3'	170	15000	13000	94	3.65	4.18	4.90	10.90	-
TQ 160 2_40	800	1200	2000	2800	3500	5'	3'	170	15000	13000	94	3.05	3.57	4.30	10.30	-
TQ 160 2_50	800	1200	2000	2800	3500	5'	3'	170	15000	13000	94	2.99	3.52	4.24	10.24	-
TQ 160 2_70	750	1150	2000	3000	3500	5'	3'	170	15000	13000	94	2.97	3.50	4.22	10.22	-
TQ 160 2_100	550	850	1600	3000	3500	5'	3'	170	15000	13000	94	2.95	3.48	4.20	10.20	-



TQK Series

The TQK right-angle series represents the ideal solution for issues of space saving, while maintaining the same top performance levels of the TQ inline series.

This series is particularly suited for the highly demanding requirements of servo systems, such as fast dynamic response, frequent reverse motion, precise position, motion control and high number of starts and stops.

Main benefits

- Highest installation flexibility
- Optional reinforced bearings for high axial and radial overload forces
- Quiet operation
- Compact design for space-saving layouts
- Great flexibility thanks to universal design

Main features

- Nominal output torque (Nm)

20 - 800

- Torsional backlash (arcmin)

4 - 8

- Torsional stiffness (Nm/arcmin)

4.3 - 167

- Max tilting moment (Nm)

129.5 - 2331

Protection class

- IP65

Frame sizes

- 060
- 070
- 090
- 130
- 160

Main options

- Input versions

MOTOR ADAPTER	WITHOUT MOTOR ADAPTER
- Output shafts versions

SMOOTH KEYLESS SHAFT	KEYED SHAFT
- Service type

S1	S5
- Lubrication

STANDARD LUBRICATION	FOOD GRADE LUBRICATION
- Bearings versions

STANDARD	REINFORCED

3 FEATURES OF TQK SERIES

Low backlash bevel-planetary drives of the TQK series are the solution to space problems often posed by increasingly compact machines. TQK drives combine high levels of dynamic operation with top precision, which results in great accuracy and repeatability for any positioning mechanism in which they are installed.

On top of their robustness and dependability TQK drives also feature a distinctive Italian style that makes them clearly recognizable amongst like products within the reference industry.

TQK

- TQK features two classes of precision, corresponding to the following values of torsional backlash
2-stage units: standard $\phi_S \leq 5'$; reduced $\phi_R \leq 4'$ ($\phi_S \leq 6'$; $\phi_R \leq 5'$ for TQK 060 and TQK 070)
3-stage units: standard $\phi_S \leq 7'$; reduced $\phi_R \leq 6'$ ($\phi_S \leq 8'$; $\phi_R \leq 7'$ for TQK 060 and TQK 070)
- A high IP rating (IP65) provides inner parts with protection against the ingress of dust and liquids.
- Input section oil seals made from a Fluoroelastomer compound are supplied as standard.
- Noise pressure level $60 \leq L_p \leq 70$ dB(A). Conditions: distance 1 m ; measured without load and an input speed of $n_1 = 3000 \text{ min}^{-1}$; $i = 20$.
- Numerous adapters allow matching the most popular brands of servomotors.
- Lubrication optimized for the type of duty specified when ordering, in the absence of contamination the lubricant requires no periodical changes.

duty	TQK 060 ... TQK 160	output seals
S1 (continuous)	Synthetic oil viscosity ISO VG 220	Fluoroelastomer
S5 (intermittent)	NLGI grease consistency 00	NBR

- Ambient temperature min -20°C , max $+30^\circ\text{C}$. For temperature higher than 30°C please consider derating factor f_T .
- Housing temperature must not exceed $T_{\text{max}} = 90^\circ\text{C}$.

		Distribution of nominal torque M_{n2} [Nm]														
	[i]	6	8	10	14	18	20	24	30	40	50	70	80	100	140	200
TQK 060		21	28	30	25	21	20	30	30	30	30	30	30	30	25	20
TQK 070		45	60	70	60	45	40	70	70	70	70	70	70	70	60	40
TQK 090		110	150	180	160	130	110	200	180	180	180	180	200	180	160	110
TQK 130		255	340	400	360	260	280	400	400	400	400	400	400	400	360	280
TQK 160		420	560	700	750	530	550	800	800	800	800	800	800	800	750	550

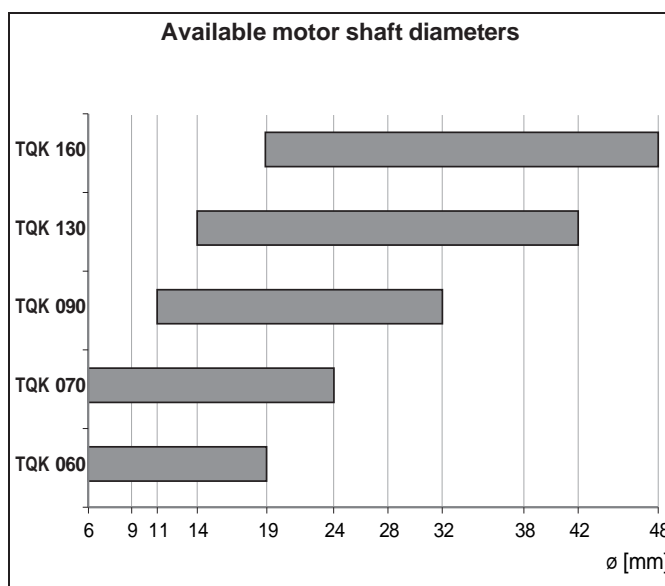
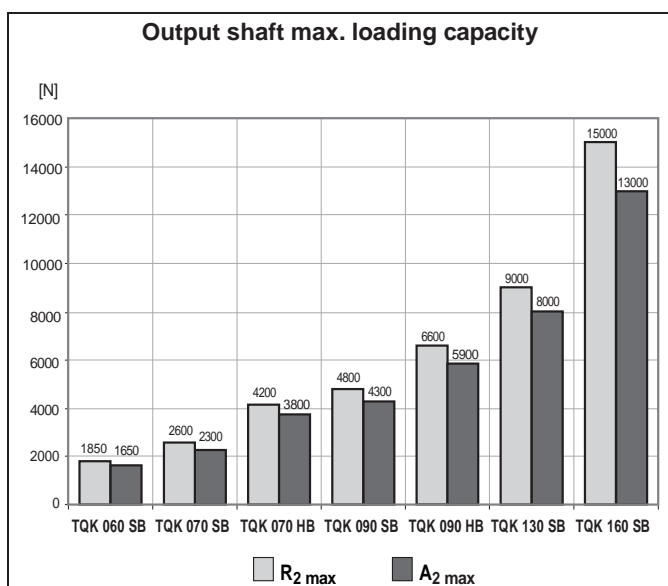

3.1 ORDERING CODE

TQK 130 2 25 STD 80A3 CD 19 S5 SB KL UH1

LUBRICANT

- standard

UH1 food grade synthetic lubricant

OUTPUT SHAFT CONFIGURATION

KL smooth keyless shaft

KE keyed shaft

OUTPUT SHAFT BEARINGS

SB standard

HB reinforced (TQK 070 - TQK 090)

DUTY

S1 continuous duty

S5 intermittent duty

INPUT SHAFT BORE

6 ... 48

MOTOR COUPLING

CD clamping device

INPUT SECTION

30A ... 230A motor adapter

FM without motor adapter

BACKLASH

	2 reduction	2 reductions (TQK060, TQK070 only)	3 reductions	3 reductions (TQK060, TQK070 only)
STD	$\phi_s \leq 5'$	$\phi_s \leq 6'$	$\phi_s \leq 7'$	$\phi_s \leq 8'$
LOW	$\phi_R \leq 4'$	$\phi_R \leq 5'$	$\phi_R \leq 6'$	$\phi_R \leq 7'$

GEAR RATIO

REDUCTIONS

2 3

FRAME SIZE

060 070 090 130 160

SERIES

TQK

3.2 DIMENSIONS AND TECHNICAL SPECIFICATIONS

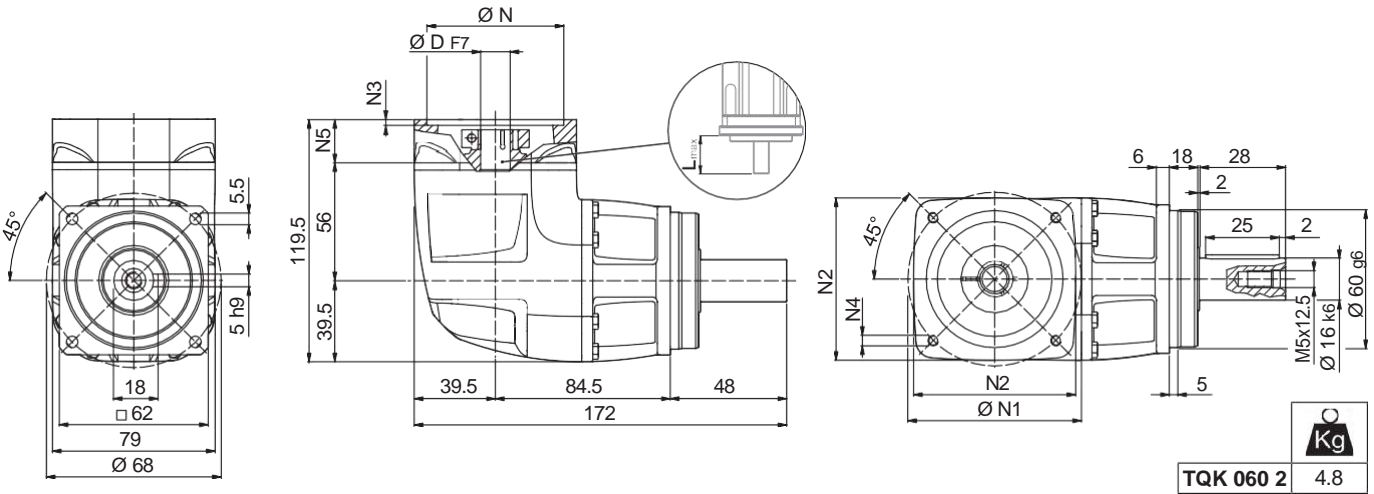

TQK 060

TQK

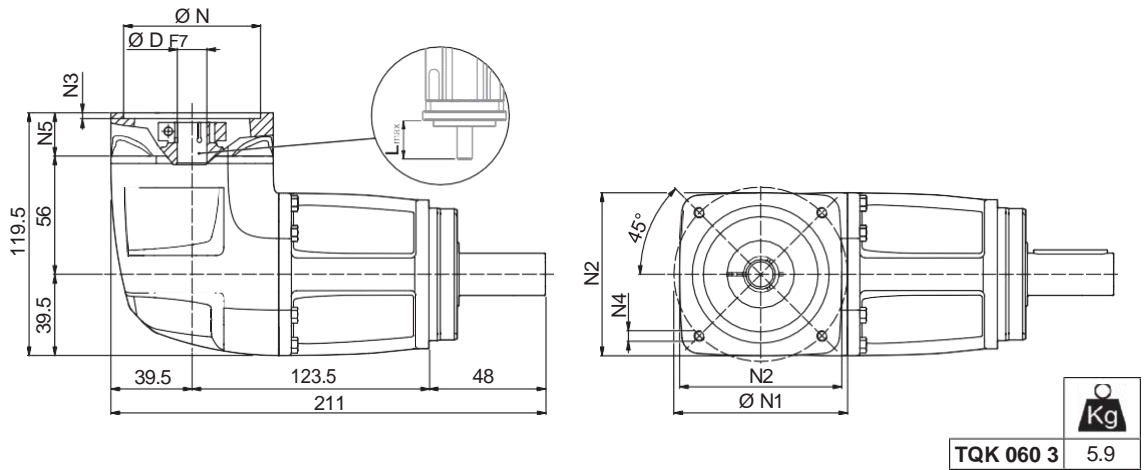

30A ... 110B0



						N	N1	N2	N3	N4	N5	L _{max}
30A	6	-	-	-	-	30	46	80	3.5	M4x10	24	40
40B1	6	9	11	14	-	40	63	80	3.5	M4x10	24	40
50A1	6	9	11	14	-	50	60	80	4.0	M4x10	24	40
50C1	6	9	11	14	-	50	70	80	4.0	M4x10	24	40
60A2	6	9	11	14	19	60	75	80	4.0	M5x12	24	40
70B1	6	9	11	14	19	70	90	80	4.0	M5x12	24	40
80A1	6	9	11	14	19	80	100	100	4.0	M6x14	24	40
95A	6	9	11	14	19	95	115	100	4.0	M8x24*	24	40
110B0	6	9	11	14	19	110	145	120	4.0	M8x24*	24	40

TQK 060

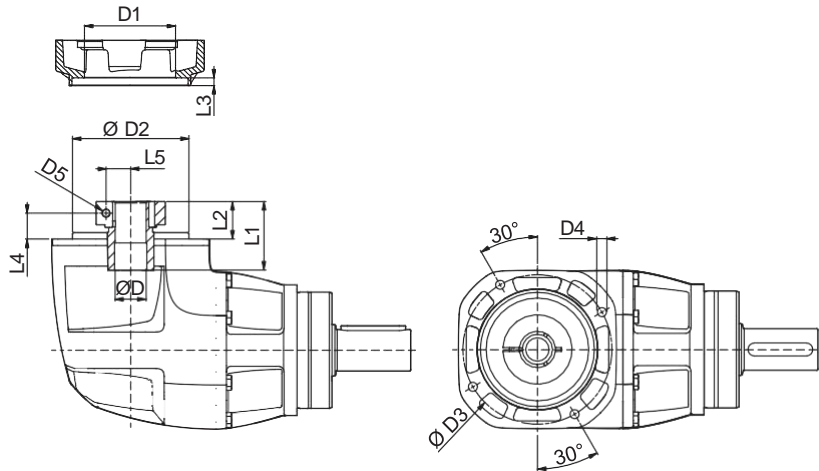
FM

	D1	D2	D3	D4	D5	L1	L2	L3	L4	L5
6	37	59	72	M5x11	M4	31.5	15.5	4.5	10.5	8
9	49	59	72	M5x11	M5	35	19	4.5	11.5	10.5
11	49	59	72	M5x11	M6	35	19	4.5	11.5	12.5
14	49	59	72	M5x11	M6	35	19	4.5	11.5	14.5
19	54	59	72	M5x11	M6	35	19	4.5	11.5	16.5

	i	M _{n2} [Nm]	M _{a2} [Nm]	M _{p2} [Nm]	n ₁ [min ⁻¹]	n _{1 max} [min ⁻¹]	ϕ _S / ϕ _R		C _t [mm arcmin]	R _{2 max} [N]	A _{2 max} [N]	η %	J _G [kgcm ²]		
							≤	≤						6 - 9	11 - 14
TQK 060 2_6		21	30	45	2500	5000	6'	5'	4.3	1850	1650	94	0.76	0.78	0.78
TQK 060 2_8		28	40	60	2500	5000	6'	5'	4.3	1850	1650	94	0.75	0.76	0.77
TQK 060 2_10		30	45	70	2500	5000	6'	5'	4.3	1850	1650	94	0.73	0.75	0.75
TQK 060 2_14		25	38	70	2500	5000	6'	5'	4.3	1850	1650	94	0.72	0.73	0.74
TQK 060 2_20		20	30	55	2500	5000	6'	5'	4.3	1850	1650	94	0.71	0.72	0.73
TQK 060 3_18		21	32	60	2500	5000	8'	7'	4.3	1850	1650	91	0.61	0.62	0.63
TQK 060 3_24		30	45	80	2500	5000	8'	7'	4.3	1850	1650	91	0.61	0.62	0.63
TQK 060 3_30		30	45	80	2500	5000	8'	7'	4.3	1850	1650	91	0.60	0.62	0.62
TQK 060 3_40		30	45	80	2500	5000	8'	7'	4.3	1850	1650	91	0.60	0.61	0.62
TQK 060 3_50		30	45	80	2500	5000	8'	7'	4.3	1850	1650	91	0.60	0.61	0.62
TQK 060 3_70		30	45	80	2500	5000	8'	7'	4.3	1850	1650	91	0.60	0.61	0.62
TQK 060 3_80		30	45	80	2500	5000	8'	7'	4.3	1850	1650	91	0.60	0.61	0.62
TQK 060 3_100		30	45	80	2500	5000	8'	7'	4.3	1850	1650	91	0.59	0.61	0.61
TQK 060 3_140		25	38	70	2500	5000	8'	7'	4.3	1850	1650	91	0.59	0.61	0.61
TQK 060 3_200		20	30	55	2500	5000	8'	7'	4.3	1850	1650	91	0.59	0.61	0.61

* through hole. Please contact us for different motor adapters and input shaft bore.

TQK 070

50C2 ... 130A

TQK

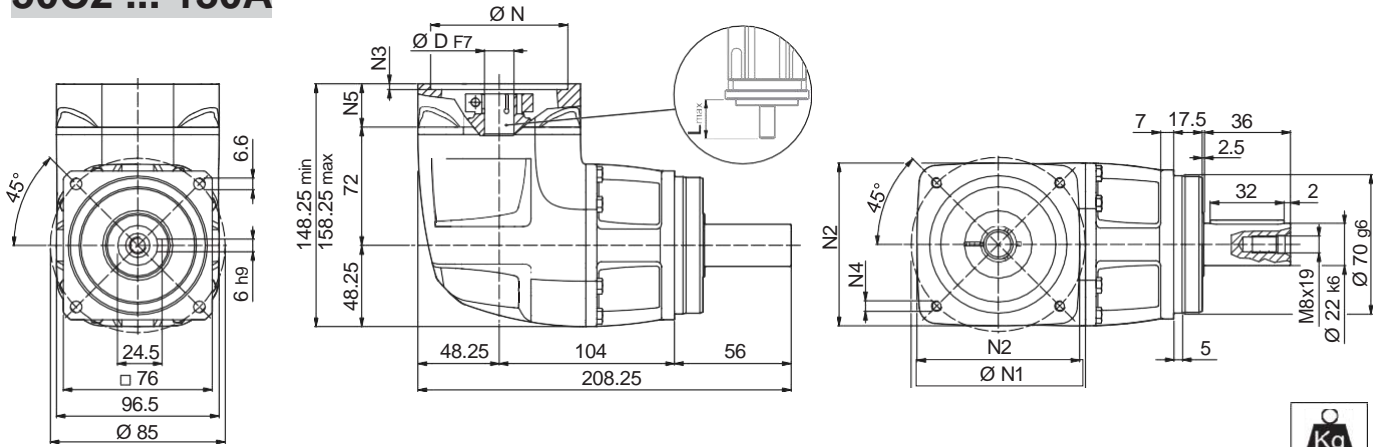

	TQK 070 2	5.9
--	------------------	-----

30A ... 110B0

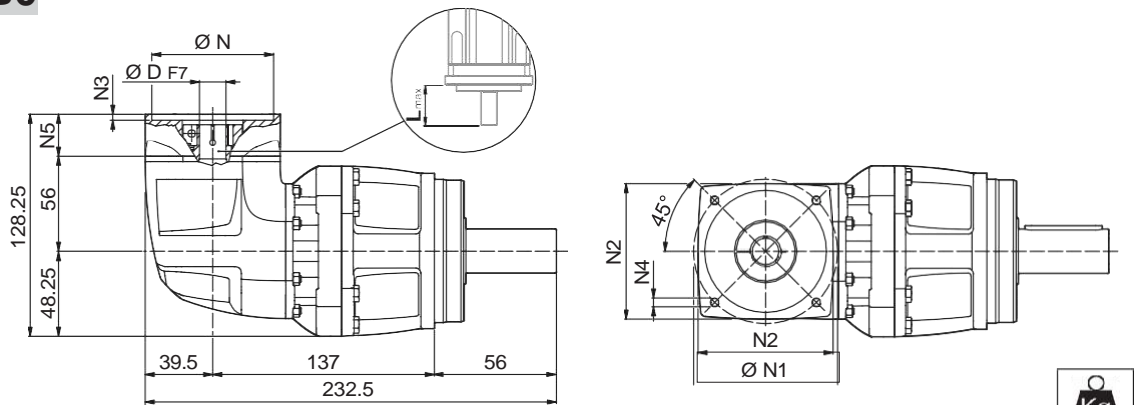



	TQK 070 3	7.3
--	------------------	-----

							N	N1	N2	N3	N4	N5	L _{max}
TQK 070 2													
50C2	6	9	11	14	–	–	50	70	100	6.5	M4x12	28	50
60A3	6	9	11	14	19	–	60	75	100	6.5	M5x14	28	50
70B2	6	9	11	14	19	–	70	90	100	6.5	M5x14	28	50
80A2	6	9	11	14	19	–	80	100	100	6.5	M6x14	28	50
95A1	6	9	11	14	19	24	95	115	100	6.5	M8x18	28	50
110A1	6	9	11	14	19	24	110	130	120	6.5	M8x18	28	50
110B1	6	9	11	14	19	24	110	145	120	6.5	M8x20	38	60
130A	6	9	11	14	19	24	130	165	140	6.5	M10x19	28	50
TQK 070 3													
30A	6	–	–	–	–	–	30	46	80	3.5	M4x10	24	40
40B1	6	9	11	14	–	–	40	63	80	3.5	M4x10	24	40
50A1	6	9	11	14	–	–	50	60	80	4.0	M4x10	24	40
50C1	6	9	11	14	–	–	50	70	80	4.0	M4x10	24	40
60A2	6	9	11	14	19	–	60	75	80	4.0	M5x12	24	40
70B1	6	9	11	14	19	–	70	90	80	4.0	M5x12	24	40
80A1	6	9	11	14	19	–	80	100	100	4.0	M6x14	24	40
95A	6	9	11	14	19	–	95	115	100	4.0	M8x24*	24	40
110B0	6	9	11	14	19	–	110	145	120	4.0	M8x24*	24	40

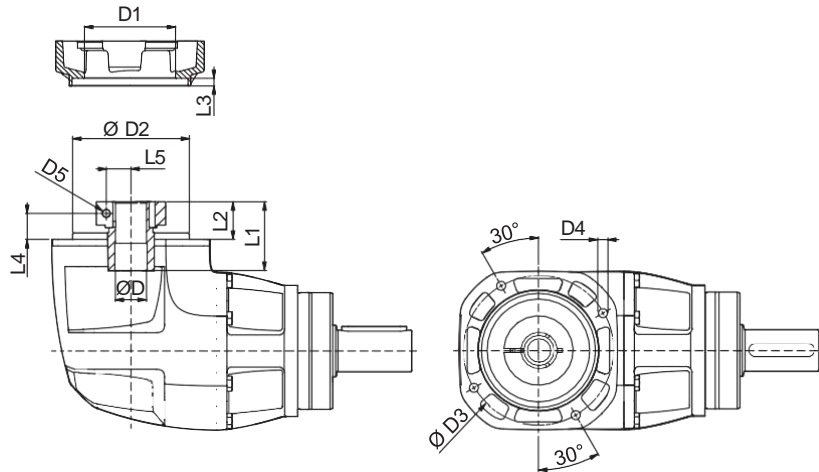
TQK 070

FM

	D1	D2	D3	D4	D5	L1	L2	L3	L4	L5
TQK 070 2										
6	51	70	85	M6x11	M6	42	20	5	12.5	12.5
9	51	70	85	M6x11	M6	42	20	5	12.5	12.5
11	51	70	85	M6x11	M6	42	20	5	12.5	12.5
14	51	70	85	M6x11	M6	42	20	5	12.5	14.5
19	51	70	85	M6x11	M6	42	20	5	12.5	16.5
24	60	70	85	M6x11	M6	43.5	21.5	5	12.5	19
TQK 070 3										
6	37	59	72	M5x11	M4	31.5	15.5	4.5	10.5	8
9	49	59	72	M5x11	M5	35	19	4.5	11.5	10.5
11	49	59	72	M5x11	M6	35	19	4.5	11.5	12.5
14	49	59	72	M5x11	M6	35	19	4.5	11.5	14.5
19	54	59	72	M5x11	M6	35	19	4.5	11.5	16.5

	i	M _{n 2} [Nm]	M _{a 2} [Nm]	M _{p 2} [Nm]	n ₁ [min ⁻¹]	n _{1 max} [min ⁻¹]	ϕ		C _t Nm α(C2111)	SB		HB		η %	J _G [kgcm ²]			
							ϕ _S	ϕ _R		R _{2 max} [N]	A _{2 max} [N]	R _{2 max} [N]	A _{2 max} [N]					
															6 - 9	11 - 14	19	24
TQK 070 2_6		45	65	90	2500	5000	6'	5'	11	2600	2300	4200	3800	94	-	1.52	1.55	1.63
TQK 070 2_8		60	85	120	2500	5000	6'	5'	11	2600	2300	4200	3800	94	-	1.44	1.47	1.55
TQK 070 2_10		70	100	150	2500	5000	6'	5'	11	2600	2300	4200	3800	94	-	1.41	1.43	1.52
TQK 070 2_14		60	90	160	2500	5000	6'	5'	11	2600	2300	4200	3800	94	-	1.38	1.41	1.49
TQK 070 2_20		40	60	110	2500	5000	6'	5'	11	2600	2300	4200	3800	94	-	1.36	1.39	1.48
TQK 070 3_18		45	65	120	2500	5000	8'	7'	11	2600	2300	4200	3800	91	1.28	1.39	1.42	-
TQK 070 3_24		70	100	180	2500	5000	8'	7'	11	2600	2300	4200	3800	91	1.26	1.37	1.40	-
TQK 070 3_30		70	100	180	2500	5000	8'	7'	11	2600	2300	4200	3800	91	1.25	1.36	1.39	-
TQK 070 3_40		70	100	180	2500	5000	8'	7'	11	2600	2300	4200	3800	91	1.20	1.31	1.34	-
TQK 070 3_50		70	100	180	2500	5000	8'	7'	11	2600	2300	4200	3800	91	1.19	1.31	1.33	-
TQK 070 3_70		70	100	180	2500	5000	8'	7'	11	2600	2300	4200	3800	91	1.18	1.29	1.32	-
TQK 070 3_80		70	100	180	2500	5000	8'	7'	11	2600	2300	4200	3800	91	1.17	1.29	1.31	-
TQK 070 3_100		70	100	180	2500	5000	8'	7'	11	2600	2300	4200	3800	91	1.17	1.28	1.31	-
TQK 070 3_140		60	90	160	2500	5000	8'	7'	11	2600	2300	4200	3800	91	1.16	1.27	1.30	-
TQK 070 3_200		40	60	110	2500	5000	8'	7'	11	2600	2300	4200	3800	91	1.15	1.27	1.29	-

* through hole. Please contact us for different motor adapters and input shaft bore.

TQK 090

60A4 ... 180A1

TQK

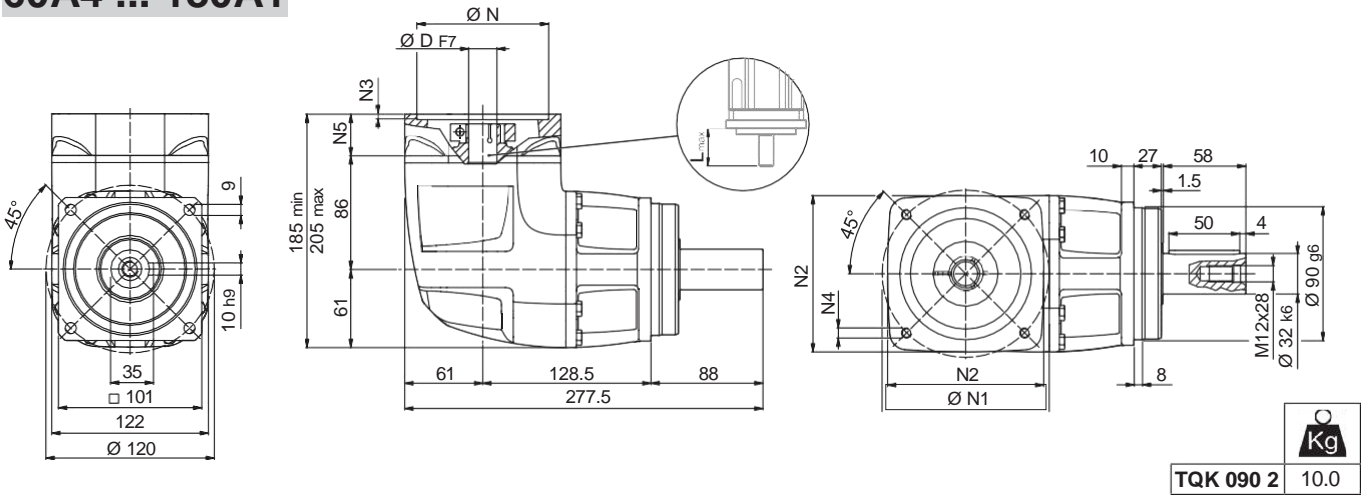

50C2 ... 130A

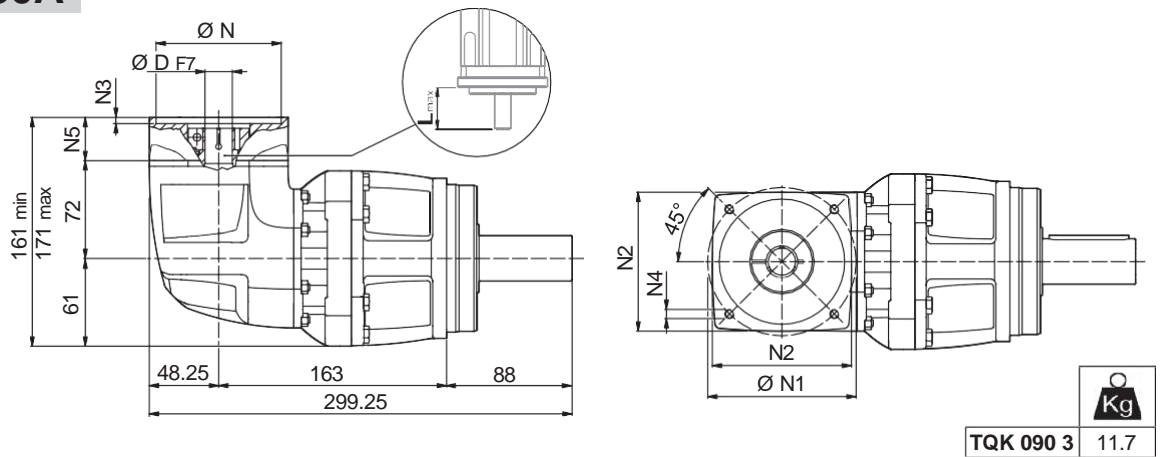

							N	N1	N2	N3	N4	N5	L _{max}
TQK 090 2													
60A4	11	14	19	-	-	-	60	75	125	6.5	M5x14	38	60
80A3	11	14	19	-	-	-	80	100	125	6.5	M6x14	38	60
95A2	11	14	19	24	28	-	95	115	125	6.5	M8x18	38	60
110A2	11	14	19	24	-	-	110	130	125	6.5	M8x20	38	60
110B1	11	14	19	24	28	-	110	145	125	6.5	M8x20	38	60
130A1	11	14	19	24	28	32	130	165	140	6.5	M10x20	38	60
180A	11	14	19	24	28	32	180	215	190	6.5	M14x38*	38	60
180A1	11	14	19	24	28	32	180	215	190	6.5	M14x28	58	80
TQK 090 3													
50C2	11	14	-	-	-	-	50	70	100	6.5	M4x12	28	50
60A3	11	14	19	-	-	-	60	75	100	6.5	M5x14	28	50
70B2	11	14	19	-	-	-	70	90	100	6.5	M5x14	28	50
80A2	11	14	19	-	-	-	80	100	100	6.5	M6x14	28	50
95A1	11	14	19	24	-	-	95	115	100	6.5	M8x18	28	50
110A1	11	14	19	24	-	-	110	130	120	6.5	M8x18	28	50
110B1	11	14	19	24	-	-	110	145	120	6.5	M8x20	38	60
130A	11	14	19	24	-	-	130	165	140	6.5	M10x19	28	50

TQK 090

FM

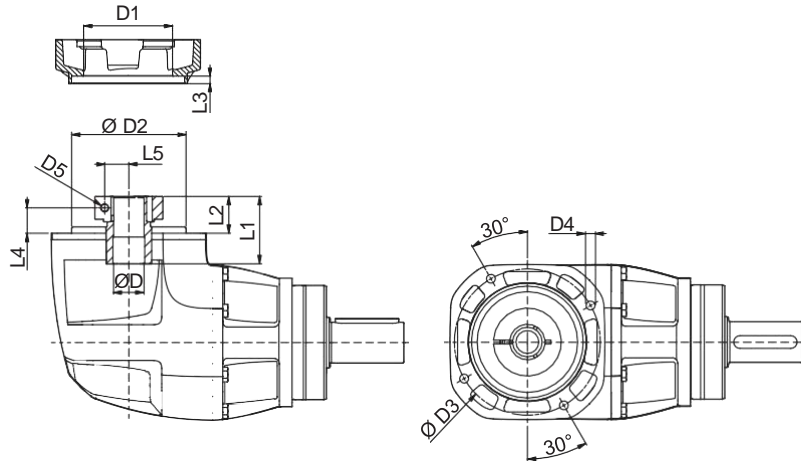

TQK

	D1	D2	D3	D4	D5	L1	L2	L3	L4	L5
TQK 090 2										
11	51	90	115	M9x13	M6	50	28	6.5	20.5	14.5
14	51	90	115	M8x13	M6	50	28	6.5	20.5	14.5
19	51	90	115	M8x13	M6	50	28	6.5	20.5	16.5
24	60	90	115	M8x13	M6	51.5	29.5	6.5	20.5	19
28	72	90	115	M8x13	M8	51.5	29.5	6.5	20.5	22.5
32	72	90	115	M8x13	M8	51.5	29.5	6.5	20.5	24.5
TQK 090 3										
11	51	70	85	M6x11	M6	42	20	5	12.5	12.5
14	51	70	85	M6x11	M6	42	20	5	12.5	14.5
19	51	70	85	M6x11	M6	42	20	5	12.5	16.5
24	60	70	85	M6x11	M6	43.5	21.5	5	12.5	19

	i	M _{n2} [Nm]	M _{a2} [Nm]	M _{p2} [Nm]	n ₁ [min ⁻¹]	n _{1 max} [min ⁻¹]	φ _S [arcmin]	φ _R [arcmin]	C _t [Nm/arcmin]	SB		HB		η %	J _G [kgcm ²]			
										R _{2 max} [N]	A _{2 max} [N]	R _{2 max} [N]	A _{2 max} [N]		11	14	19 - 24	28 - 32
TQK 090 2_6		110	150	225	2000	4500	5'	4'	28	4800	4300	6600	5900	94	-	4.82	4.89	5.42
TQK 090 2_8		150	208	300	2000	4500	5'	4'	28	4800	4300	6600	5900	94	-	4.56	4.63	5.16
TQK 090 2_10		180	260	360	2000	4500	5'	4'	28	4800	4300	6600	5900	94	-	4.45	4.51	5.04
TQK 090 2_14		160	250	500	2000	4500	5'	4'	28	4800	4300	6600	5900	94	-	4.34	4.41	4.94
TQK 090 2_20		110	170	350	2000	4500	5'	4'	28	4800	4300	6600	5900	94	-	4.29	4.36	4.88
TQK 090 3_18		130	200	400	2000	4500	7'	6'	28	4800	4300	6600	5900	91	3.56	3.63	3.70	-
TQK 090 3_24		200	300	500	2000	4500	7'	6'	28	4800	4300	6600	5900	91	3.53	3.60	3.67	-
TQK 090 3_30		180	280	500	2000	4500	7'	6'	28	4800	4300	6600	5900	91	3.52	3.59	3.66	-
TQK 090 3_40		180	280	500	2000	4500	7'	6'	28	4800	4300	6600	5900	91	3.45	3.52	3.58	-
TQK 090 3_50		180	280	500	2000	4500	7'	6'	28	4800	4300	6600	5900	91	3.42	3.49	3.56	-
TQK 090 3_70		180	280	500	2000	4500	7'	6'	28	4800	4300	6600	5900	91	3.40	3.46	3.53	-
TQK 090 3_80		200	300	500	2000	4500	7'	6'	28	4800	4300	6600	5900	91	3.38	3.45	3.52	-
TQK 090 3_100		180	280	500	2000	4500	7'	6'	28	4800	4300	6600	5900	91	3.38	3.45	3.52	-
TQK 090 3_140		160	250	500	2000	4500	7'	6'	28	4800	4300	6600	5900	91	3.38	3.45	3.52	-
TQK 090 3_200		110	170	350	2000	4500	7'	6'	28	4800	4300	6600	5900	91	3.38	3.45	3.52	-

* through hole. Please contact us for different motor adapters and input shaft bore.

TQK 130

80A3 ... 200A

TQK

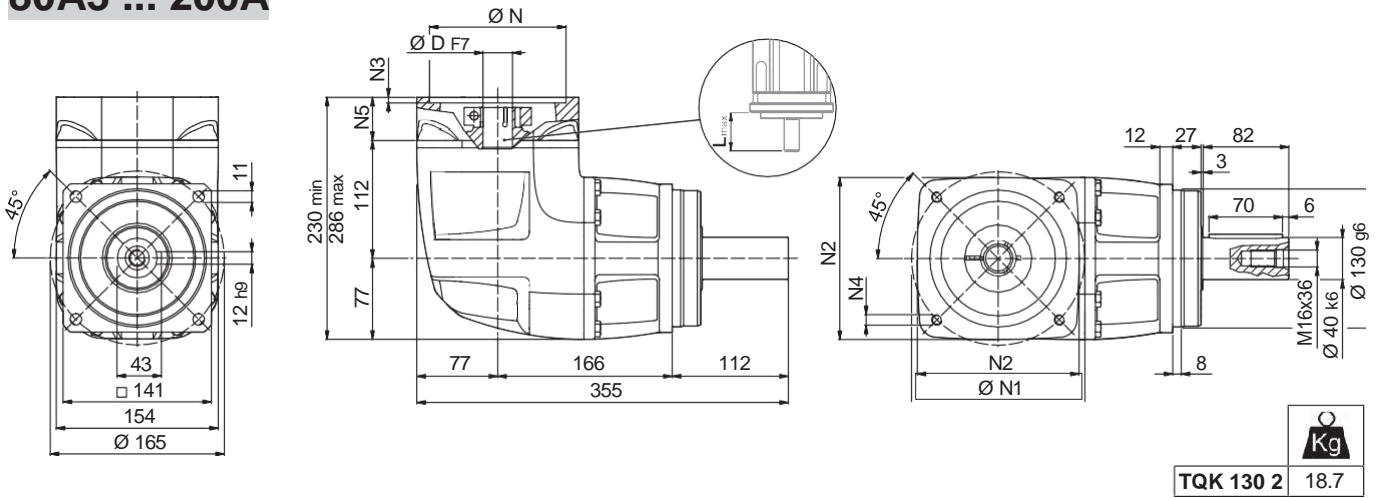

TQK 130 2 18.7

60A4 ... 180A1

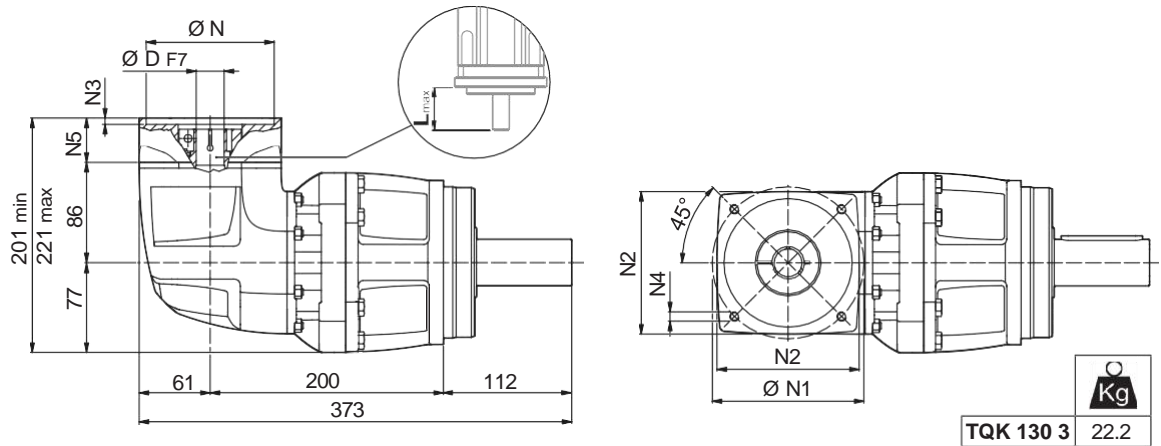

TQK 130 3 22.2

								N	N1	N2	N3	N4	N5	L _{max}
TQK 130 2														
80A3	14	19	-	-	-	-	80	100	155	6.5	M6x14	41	60	
95A2	14	19	24	28	-	-	95	115	155	6.5	M8x18	41	60	
110A2	14	19	24	-	-	-	110	130	155	6.5	M8x20	41	60	
110B1	14	19	24	28	-	-	110	145	155	6.5	M8x20	41	60	
130A1	14	19	24	28	32	-	130	165	155	6.5	M10x20	41	60	
180A	14	19	24	28	32	-	180	215	190	6.5	M14x28	41	60	
180A1	14	19	24	28	32	38	180	215	190	6.5	M14x28	61	80	
200A	14	19	24	28	32	38	200	235	220	6.5	M14x28	97	110	
TQK 130 3														
60A4	14	19	-	-	-	-	60	75	125	6.5	M5x14	38	60	
80A3	14	19	-	-	-	-	80	100	125	6.5	M6x14	38	60	
95A2	14	19	24	28	-	-	95	115	125	6.5	M8x18	38	60	
110A2	14	19	24	-	-	-	110	130	125	6.5	M8x20	38	60	
110B1	14	19	24	28	-	-	110	145	125	6.5	M8x20	38	60	
130A1	14	19	24	28	32	-	130	165	140	6.5	M10x20	38	60	
180A	14	19	24	28	32	-	180	215	190	6.5	M14x38	38	60	
180A1	14	19	24	28	32	-	180	215	190	6.5	M14x28	58	80	

TQK 130

FM

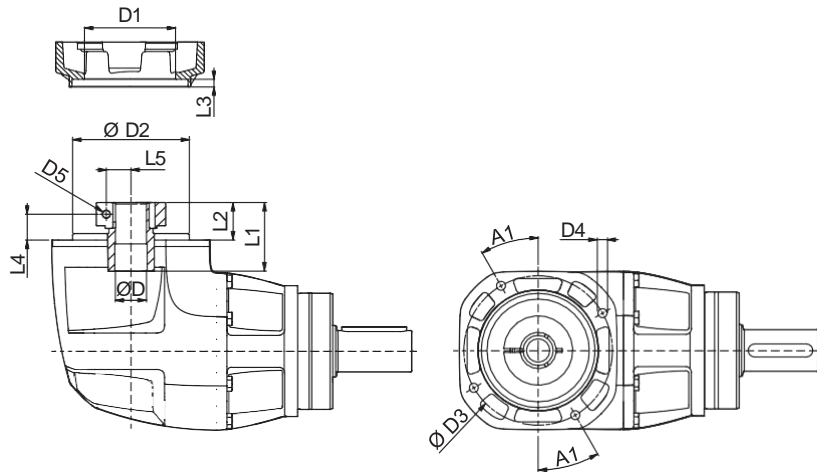

TQK

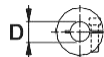
	A1	D1	D2	D3	D4	D5	L1	L2	L3	L4	L5
TQK 130 2											
14	22°	54	120	140	M10x16	M6	50	31	7.5	23.5	16.5
19	22°	54	120	140	M10x16	M6	50	31	7.5	23.5	16.5
24	22°	70	120	140	M10x16	M6	51.5	32.5	7.5	23.5	19
28	22°	70	120	140	M10x16	M8	51.5	32.5	7.5	23.5	22.5
32	22°	72	120	140	M10x16	M8	51.5	32.5	7.5	23.5	24.5
38	22°	100	120	140	M10x16	M8	54	35	7.5	23.5	28
42	22°	114	120	140	M10x16	M10	51.5	38.5	7.5	23.5	33
TQK 130 3											
14	30°	51	90	115	M8x13	M6	50	28	6.5	20.5	14.5
19	30°	51	90	115	M8x13	M6	50	28	6.5	20.5	16.5
24	30°	60	90	115	M8x13	M6	51.5	29.5	6.5	20.5	19
28	30°	72	90	115	M8x13	M8	51.5	29.5	6.5	20.5	22.5
32	30°	72	90	115	M8x13	M8	51.5	29.5	6.5	20.5	24.5

	i	M _{n2} [Nm]	M _{a2} [Nm]	M _{p2} [Nm]	n ₁ [min ⁻¹]	n _{1 max} [min ⁻¹]	ϕ _S [arcmin]	ϕ _R [arcmin]	C _t N/m [arcmin]	R _{2 max} [N]	A _{2 max} [N]	η %	J _e [kgcm ²]				
													14	19 - 24	28 - 32	38	42
TQK 130 2_6		255	360	510	2000	4500	5'	4'	56	9000	8000	94	-	17.44	18.02	18.55	24.47
TQK 130 2_8		340	480	680	2000	4500	5'	4'	56	9000	8000	94	-	16.31	16.89	17.41	23.33
TQK 130 2_10		400	600	850	2000	4500	5'	4'	56	9000	8000	94	-	15.77	16.35	16.88	22.80
TQK 130 2_14		360	550	950	2000	4500	5'	4'	56	9000	8000	94	-	15.35	15.93	16.46	22.38
TQK 130 2_20		280	420	900	2000	4500	5'	4'	56	9000	8000	94	-	15.13	15.71	16.23	22.15
TQK 130 3_18		260	400	900	2000	4500	7'	6'	56	9000	8000	91	15.18	15.34	15.92	-	-
TQK 130 3_24		400	600	1000	2000	4500	7'	6'	56	9000	8000	91	15.05	15.21	15.79	-	-
TQK 130 3_30		400	600	1000	2000	4500	7'	6'	56	9000	8000	91	14.99	15.15	15.73	-	-
TQK 130 3_40		400	600	1000	2000	4500	7'	6'	56	9000	8000	91	14.72	14.88	15.46	-	-
TQK 130 3_50		400	600	1000	2000	4500	7'	6'	56	9000	8000	91	14.61	14.77	15.35	-	-
TQK 130 3_70		400	600	1000	2000	4500	7'	6'	56	9000	8000	91	14.52	14.68	15.25	-	-
TQK 130 3_80		400	600	1000	2000	4500	7'	6'	56	9000	8000	91	14.47	14.63	15.21	-	-
TQK 130 3_100		400	600	1000	2000	4500	7'	6'	56	9000	8000	91	14.46	14.62	15.20	-	-
TQK 130 3_140		360	550	950	2000	4500	7'	6'	56	9000	8000	91	14.46	14.62	15.20	-	-
TQK 130 3_200		280	420	900	2000	4500	7'	6'	56	9000	8000	91	14.46	14.62	15.20	-	-

* through hole. Please contact us for different motor adapters and input shaft bore.

TQK 160

95A2 ... 230A

TQK

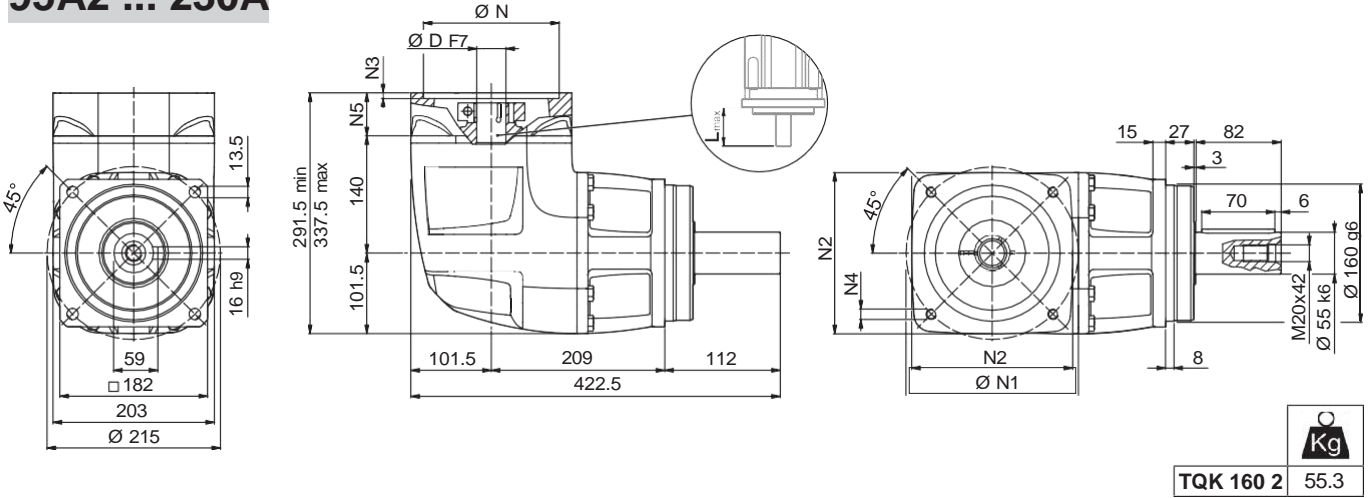

80A3 ... 200A

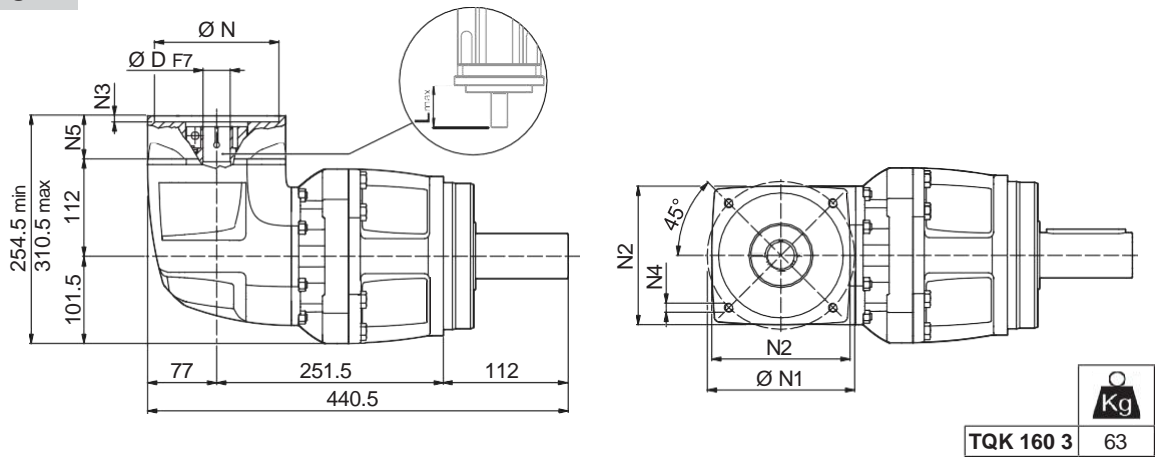

								N	N1	N2	N3	N4	N5	L _{max}
TQK 160 2														
95A2	19	24	28	-	-	-	-	95	115	205	6.5	M8x20	50	60
110A2	19	24	-	-	-	-	-	110	130	205	6.5	M8x20	50	60
130A1	19	24	28	32	-	-	-	130	165	205	6.5	M10x20	50	60
180A	19	24	28	32	-	-	-	180	215	205	6.5	M14x28	50	60
180A1	19	24	28	32	38	-	-	180	215	205	6.5	M14x28	60	80
200A	19	24	28	32	38	42	48	200	235	220	6.5	M14x28	96	110
230A	19	24	28	32	38	42	48	230	265	240	6.5	M14x28	96	110
TQK 160 3														
80A3	19	-	-	-	-	-	-	80	100	155	6.5	M6x14	41	60
95A2	19	24	28	-	-	-	-	95	115	155	6.5	M8x18	41	60
110A2	19	24	-	-	-	-	-	110	130	155	6.5	M8x20	41	60
110B1	19	24	28	-	-	-	-	110	145	155	6.5	M8x20	41	60
130A1	19	24	28	32	-	-	-	130	165	155	6.5	M10x20	41	60
180A	19	24	28	32	-	-	-	180	215	190	6.5	M14x28	41	60
180A1	19	24	28	32	38	-	-	180	215	190	6.5	M14x28	61	80
200A	19	24	28	32	38	42	-	200	235	220	6.5	M14x28	97	110

Please contact us for different motor adapters and input shaft bore.

TQK 160

FM

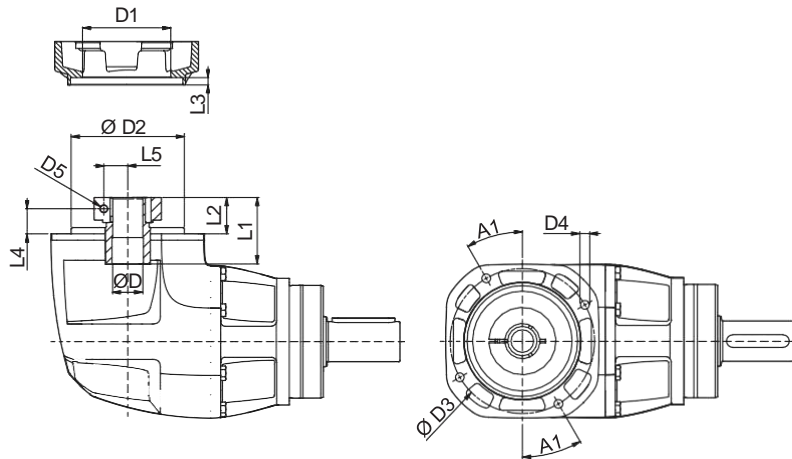

TQK

	A1	D1	D2	D3	D4	D5	L1	L2	L3	L4	L5
TQK 160 2											
19	30°	58	150	175	M12x20	M6	47	37	9.5	28	19
24	30°	58	150	175	M12x20	M6	47	37	9.5	28	19
28	30°	70	150	175	M12x20	M8	47	37	9.5	28	22.5
32	30°	72	150	175	M12x20	M8	47	37	9.5	28	24.5
38	30°	100	150	175	M12x20	M8	59.5	39.5	9.5	28	28
42	30°	114	150	175	M12x20	M10	57	45	9.5	28	33
48	30°	125	150	175	M12x20	M12	57	45	9.5	28	36.5
TQK 160 3											
19	22°	54	120	140	M10x16	M6	50	31	7.5	23.5	16.5
24	22°	70	120	140	M10x16	M6	51.5	32.5	7.5	23.5	19
28	22°	70	120	140	M10x16	M8	51.5	32.5	7.5	23.5	22.5
32	22°	72	120	140	M10x16	M8	51.5	32.5	7.5	23.5	24.5
38	22°	100	120	140	M10x16	M8	54	35	7.5	23.5	28
42	22°	114	120	140	M10x16	M10	51.5	38.5	7.5	23.5	33

	M_{n2}	M_{a2}	M_{p2}	n_1	$n_{1 \max}$	ϕ_S	ϕ_R	C_t	$R_{2 \max}$	$A_{2 \max}$	η	J_G [kgcm ²]				
												\leq	$\frac{Nm}{arcmin}$	[N]	[N]	%
TQK 160 2_6	420	630	840	1600	4000	5'	4'	167	15000	13000	94	-	73.33	73.51	75.57	79.19
TQK 160 2_8	560	840	1120	1600	4000	5'	4'	167	15000	13000	94	-	69.49	69.66	71.73	75.34
TQK 160 2_10	700	1050	1400	1600	4000	5'	4'	167	15000	13000	94	-	67.98	68.16	70.22	73.83
TQK 160 2_14	750	1150	2000	1600	4000	5'	4'	167	15000	13000	94	-	66.68	66.85	68.92	72.53
TQK 160 2_20	550	850	1600	1600	4000	5'	4'	167	15000	13000	94	-	65.94	66.12	68.18	71.80
TQK 160 3_18	530	800	1500	1600	4000	7'	6'	167	15000	13000	91	66.84	67.17	67.34	69.41	-
TQK 160 3_24	800	1200	2000	1600	4000	7'	6'	167	15000	13000	91	66.47	66.79	66.97	69.03	-
TQK 160 3_30	800	1200	2000	1600	4000	7'	6'	167	15000	13000	91	66.30	66.63	66.80	68.87	-
TQK 160 3_40	800	1200	2000	1600	4000	7'	6'	167	15000	13000	91	65.41	65.73	65.91	67.97	-
TQK 160 3_50	800	1200	2000	1600	4000	7'	6'	167	15000	13000	91	64.99	65.32	65.49	67.56	-
TQK 160 3_70	800	1200	2000	1600	4000	7'	6'	167	15000	13000	91	64.67	65.00	65.17	67.24	-
TQK 160 3_80	800	1200	2000	1600	4000	7'	6'	167	15000	13000	91	64.51	64.84	65.01	67.08	-
TQK 160 3_100	800	1200	2000	1600	4000	7'	6'	167	15000	13000	91	64.49	64.82	65.00	67.06	-
TQK 160 3_140	750	1150	2000	1600	4000	7'	6'	167	15000	13000	91	64.48	64.81	64.99	67.05	-
TQK 160 3_200	550	850	1600	1600	4000	7'	6'	167	15000	13000	91	64.47	64.80	64.98	67.04	-

Performance Line

TQF

TQF Series

The TQF series features a standardized and exceptionally compact flange interface for easy installations.

High tilting moment, high stiffness and overload capacity characterize this robust gearbox within its product category.



Main benefits

- High positioning accuracy
- High compactness
- Easy installation thanks to standardized flange design
- Highest overload capacity
- Great flexibility thanks to universal design

Main features

- Nominal output torque (Nm)

20 - 800

- Torsional backlash (arcmin)

3 - 7

- Torsional stiffness (Nm/arcmin)

12 - 500

- Max tilting moment (Nm)

115 - 3700

Protection class

- IP65

Frame sizes

- 060
- 070
- 090
- 130
- 160

Main options

- Input versions

MOTOR ADAPTER	WITHOUT MOTOR ADAPTER
- Service type

S1	S5
- Lubrication

STANDARD LUBRICATION	FOOD GRADE LUBRICATION

4 FEATURES OF NEW TQF SERIES

Low backlash planetary drives of the TQF series feature a flange on the output shaft and are ideally suited for high positioning accuracy and highly dynamic cyclic operation.

Their design and construction has been developed with the goal of offering a line of product, which features exceptional performance, highest level of stiffness, low backlash and compactness.

- TQF features two classes of precision, corresponding to the following values of torsional backlash
1-stage units: standard $\phi_S \leq 5'$ reduced $\phi_R \leq 3'$
2-stage units: standard $\phi_S \leq 7'$ reduced $\phi_R \leq 5'$
- A high IP rating (IP65) provides inner parts with protection against the ingress of dust and liquids.
- Input section oil seals made from a Fluoroelastomer compound are supplied as standard.
- Noise pressure level $60 \leq L_p \leq 70$ dB(A). Conditions: distance 1 m ; measured without load and an input speed of $n_1 = 3000 \text{ min}^{-1}$; $i = 10$.
- Numerous adapters allow matching the most popular brands of servomotors.
- Lubrication optimized for the type of duty specified when ordering.
In the absence of contamination the lubricant requires no periodical changes.

duty	TQF 060 ... TQF 160	output seals
S1 (continuous)	Synthetic oil viscosity ISO VG 220	Fluoroelastomer
S5 (intermittent)	NLGI grease consistency 00	NBR

- Ambient temperature min -20°C , max $+30^\circ\text{C}$. For temperature higher than 30°C please consider derating factor f_T .
- Housing temperature must not exceed $T_{\text{max}} = 90^\circ\text{C}$.

		Distribution of nominal torque M_{n2} [Nm]												
[i]		4	5	7	10	16	20	25	28	35	40	50	70	100
TQF 060		30	30	25	20	30	30	30	30	30	30	30	25	20
TQF 070		70	70	60	40	70	70	70	70	70	70	70	60	40
TQF 090		200	180	160	110	200	180	180	200	180	200	180	160	110
TQF 130		400	400	360	280	400	400	400	400	400	400	400	360	280
TQF 160		800	800	750	550	800	800	800	800	800	800	800	750	550

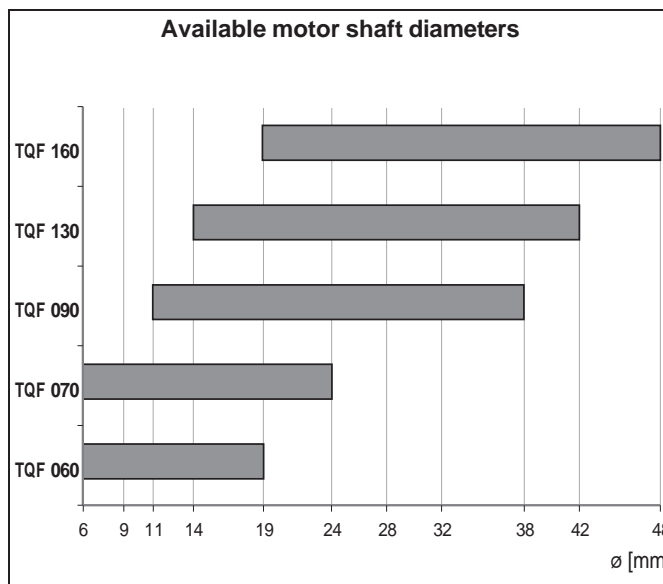
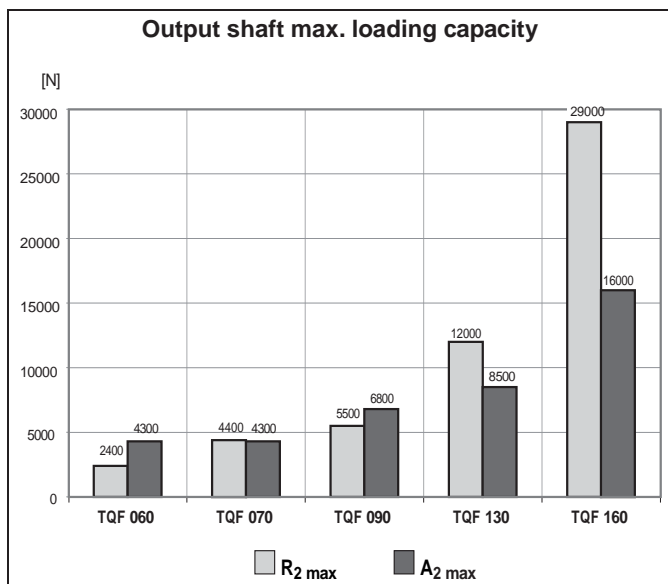

4.1 ORDERING CODE

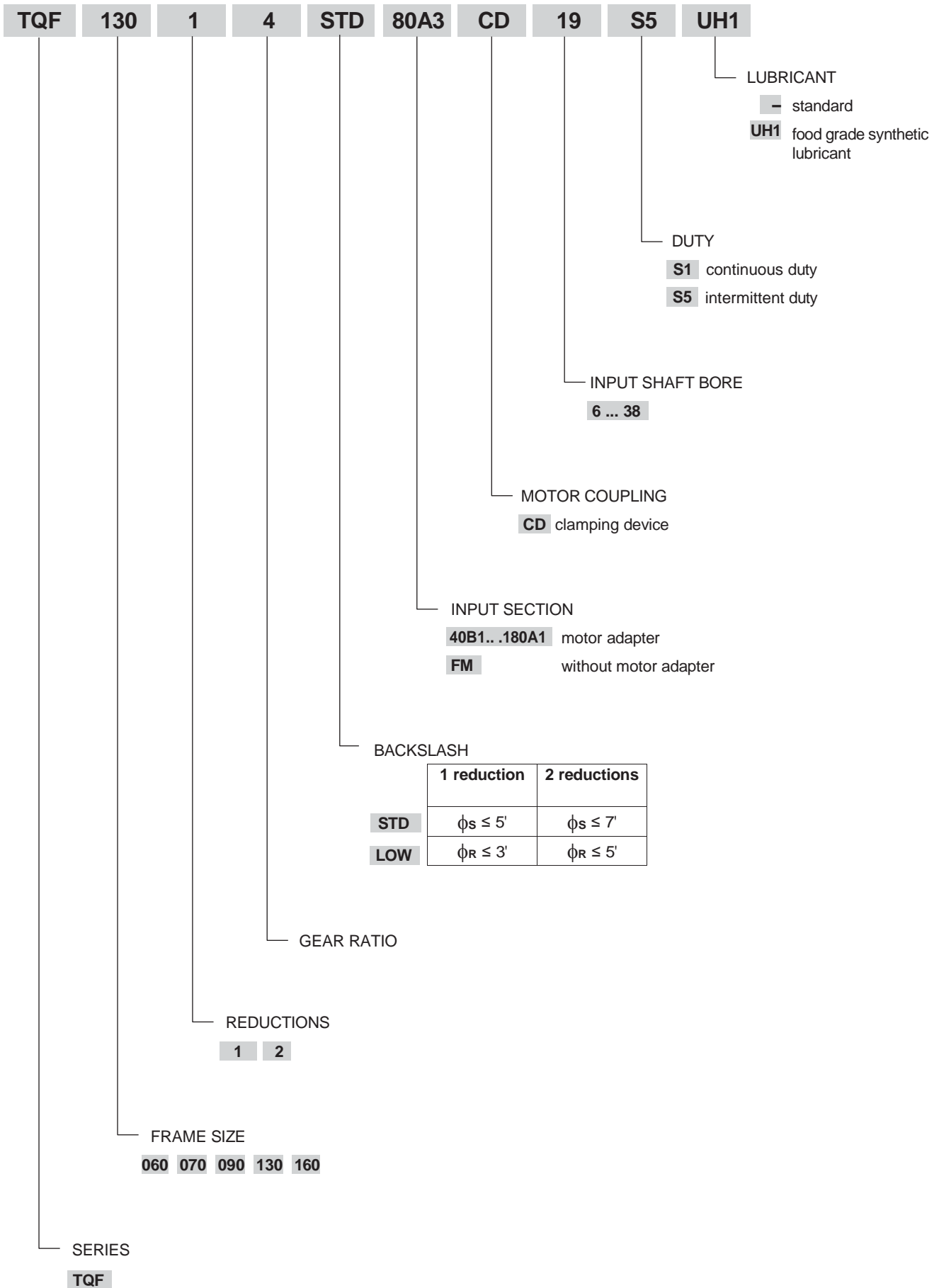

TQF

4.2 DIMENSIONS AND TECHNICAL SPECIFICATIONS

TQF 060

TQF

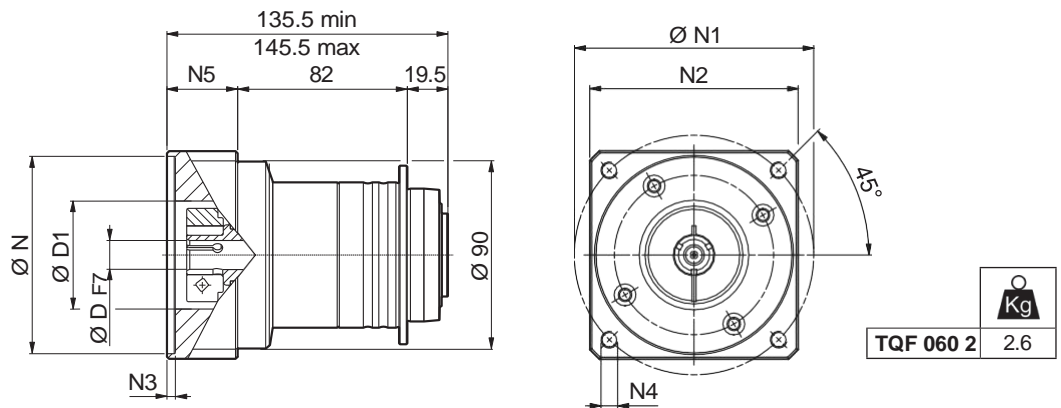
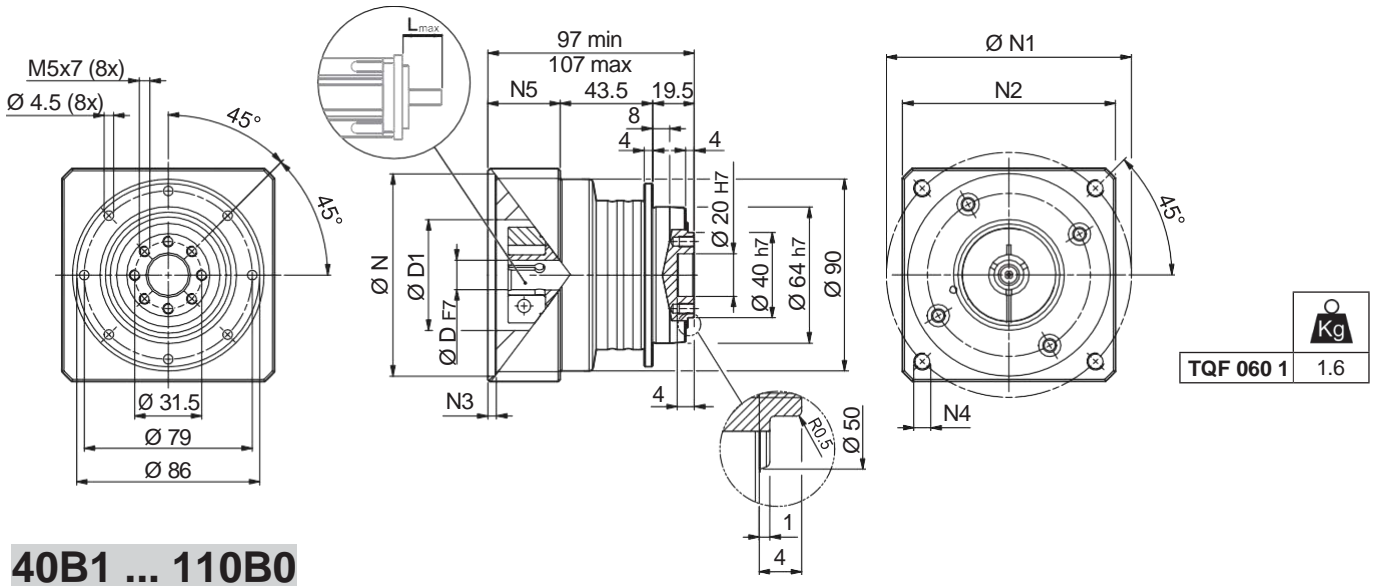

						N	N1	N2	N3	N4	N5	L _{max}
40B1	6	9	11	14	-	40	63	80	4	M4x12	34	40
50A1	6	9	11	14	-	50	60	80	4	M4x10	34	40
50C1	6	9	11	14	-	50	70	80	4	M4x10	34	40
60A2	6	9	11	14	19	60	75	80	4	M5x16	34	40
70B1	6	9	11	14	19	70	90	80	4	M5x16	34	40
80A1	6	9	11	14	19	80	100	90	4	M6x16	34	40
95A	6	9	11	14	19	95	115	100	6.5	M8x20	34	40
110B0	6	9	11	14	19	110	145	120	6.5	M8x20	44	40

Please contact us for different motor adapters and input shaft bore.

TQF 060

FM

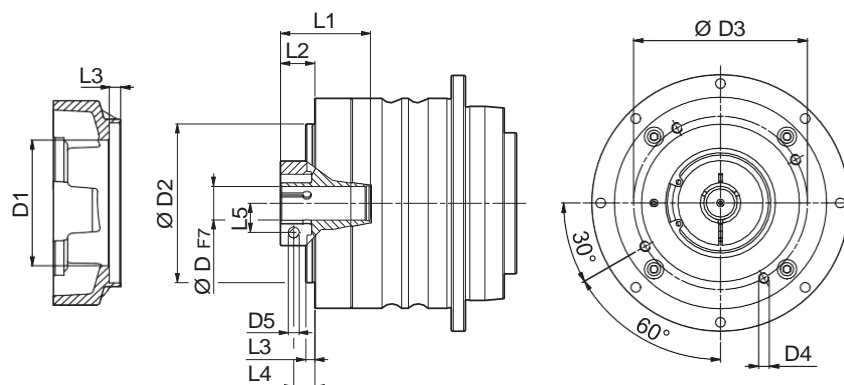

TQF

	D1	D2	D3	D4	D5	L1	L2	L3	L4	L5
6	37	68	76.5	M6x12	M4	31.5	21	7.5	16	8
9	49	68	76.5	M6x12	M5	35	24.5	7.5	17	10.5
11	49	68	76.5	M6x12	M6	35	24.5	7.5	17	12.5
14	49	68	76.5	M6x12	M6	35	24.5	7.5	17	14.5
19	54	68	76.5	M6x12	M6	35	24.5	7.5	17	16.5

	M_{n2}	M_{a2}	M_{p2}	n_1	$n_{1\max}$	$\phi_S \leq \phi_R$		C_t	$R_{2\max}$	$A_{2\max}$	η	J_G [kgcm ²]		
						[Nm]	[Nm]					[Nm]	[min ⁻¹]	[min ⁻¹]
TQF 060 1_4	30	45	80	3500	6000	5'	3'	12	2400	4300	97	0.32	0.43	0.47
TQF 060 1_5	30	45	80	3500	6000	5'	3'	12	2400	4300	97	0.27	0.39	0.42
TQF 060 1_7	25	38	70	4000	6000	5'	3'	12	2400	4300	97	0.23	0.35	0.38
TQF 060 1_10	20	30	55	4000	6000	5'	3'	12	2400	4300	97	0.21	0.33	0.36
TQF 060 2_16	30	45	80	4500	6000	7'	5'	12	2400	4300	94	0.28	0.39	0.43
TQF 060 2_20	30	45	80	4500	6000	7'	5'	12	2400	4300	94	0.27	0.39	0.42
TQF 060 2_25	30	45	80	4500	6000	7'	5'	12	2400	4300	94	0.25	0.36	0.40
TQF 060 2_28	30	45	80	4500	6000	7'	5'	12	2400	4300	94	0.22	0.34	0.37
TQF 060 2_35	30	45	80	4500	6000	7'	5'	12	2400	4300	94	0.22	0.33	0.37
TQF 060 2_40	30	45	80	4500	6000	7'	5'	12	2400	4300	94	0.21	0.32	0.36
TQF 060 2_50	30	45	80	4500	6000	7'	5'	12	2400	4300	94	0.21	0.32	0.36
TQF 060 2_70	25	38	70	5000	6000	7'	5'	12	2400	4300	94	0.21	0.32	0.36
TQF 060 2_100	20	30	55	5000	6000	7'	5'	12	2400	4300	94	0.21	0.32	0.36

TQF 070

50C2 ... 130A

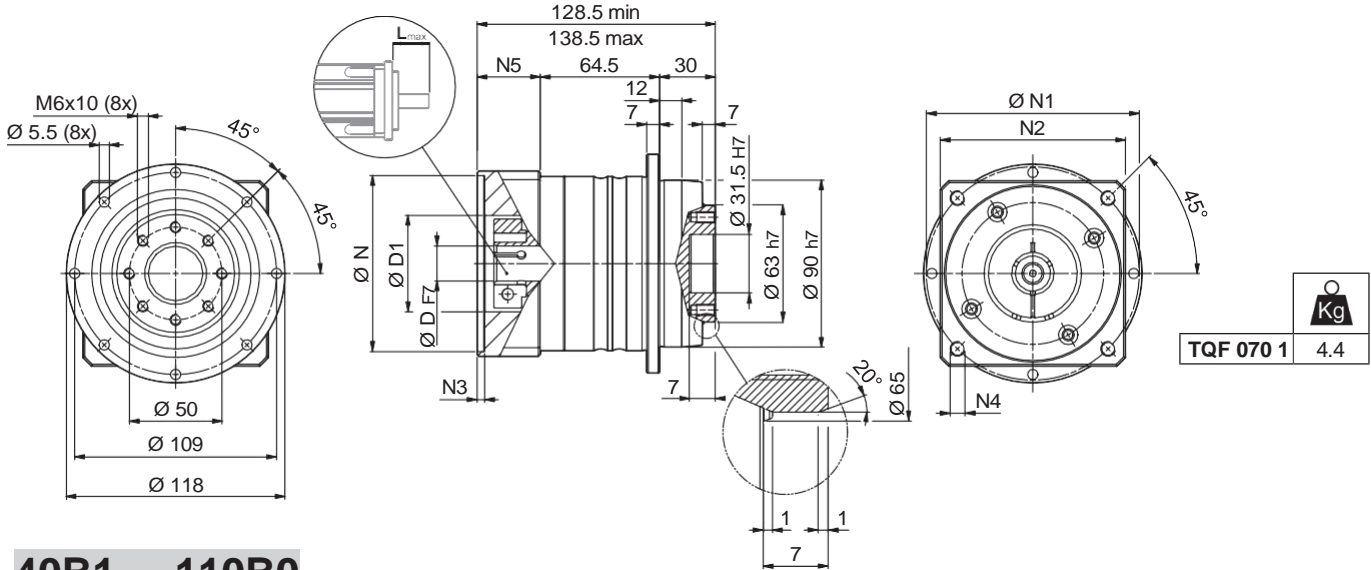

40B1 ... 110B0

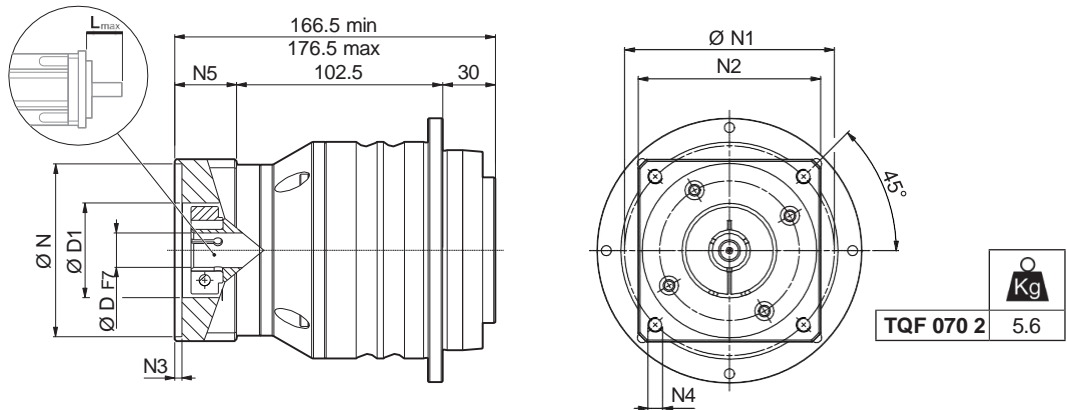

							N	N1	N2	N3	N4	N5	L _{max}
TQF 070 1													
50C2	6	9	11	14	-	-	50	70	80	4	M4x10	34	50
60A3	6	9	11	14	19	-	60	75	80	4	M5x16	34	50
70B2	6	9	11	14	19	-	70	90	80	4	M5x16	34	50
80A2	6	9	11	14	19	-	80	100	90	4	M6x16	34	50
95A1	6	9	11	14	19	24	95	115	100	6.5	M8x20	34	50
110A1	6	9	11	14	19	24	110	130	115	6.5	M8x20	34	50
110B1	6	9	11	14	19	24	110	145	120	6.5	M8x20	44	60
130A	6	9	11	14	19	24	130	165	140	6.5	M10x19	34	50
TQF 070 2													
40B1	6	9	11	14	-	-	40	63	80	4	M4x12	34	40
50A1	6	9	11	14	-	-	50	60	80	4	M4x10	34	40
50C1	6	9	11	14	-	-	50	70	80	4	M4x10	34	40
60A2	6	9	11	14	19	-	60	75	80	4	M5x16	34	40
70B1	6	9	11	14	19	-	70	90	80	4	M5x16	34	40
80A1	6	9	11	14	19	-	80	100	90	4	M6x16	34	40
95A	6	9	11	14	19	-	95	115	100	6.5	M8x20	34	40
110B0	6	9	11	14	19	-	110	145	120	6.5	M8x20	44	40

Please contact us for different motor adapters and input shaft bore.

TQF 070

FM

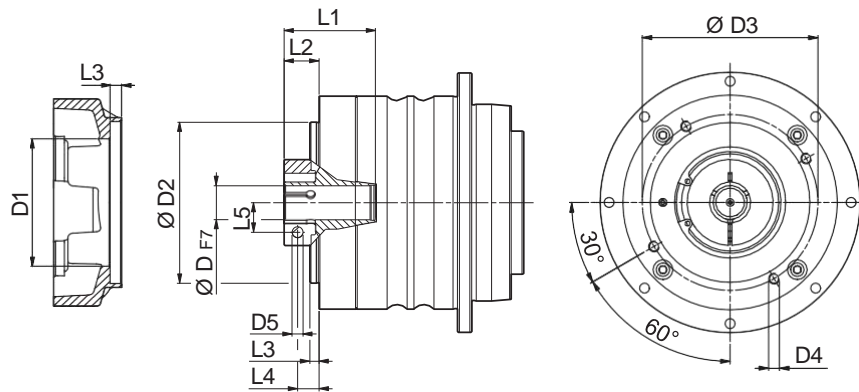

TQF

	D1	D2	D3	D4	D5	L1	L2	L3	L4	L5
TQF 070 1										
6	37	68	76.5	M6x14	M4	45	25	9	19	8
9	49	68	76.5	M6x14	M5	42	25	9	18.5	10.5
11	51	68	76.5	M6x14	M6	42	25	9	17.5	12.5
14	51	68	76.5	M6x14	M6	42	25	9	17.5	14.5
19	51	68	76.5	M6x14	M6	42	25	9	17.5	16.5
24	60	68	76.5	M6x14	M6	43.5	26.5	9	17.5	19
TQF 070 2										
6	37	68	76.5	M6x12	M4	31.5	21	7.5	16	8
9	49	68	76.5	M6x12	M5	35	24.5	7.5	17	10.5
11	49	68	76.5	M6x12	M6	35	24.5	7.5	17	12.5
14	49	68	76.5	M6x12	M6	35	24.5	7.5	17	14.5
19	54	68	76.5	M6x12	M6	35	24.5	7.5	17	16.5

	M_{n2}	M_{a2}	M_{p2}	n_1	$n_{1\max}$	$\phi_s \leq \phi_R$		C_t	$R_{2\max}$	$A_{2\max}$	η	J_G [kgcm ²]			
						[Nm]	[Nm]					[Nm]	[min ⁻¹]	[min ⁻¹]	[arcmin]
TQF 070 1_4	70	100	180	3000	6000	5'	3'	29	4400	4300	97	-	1.05	1.09	1.22
TQF 070 1_5	70	100	180	3000	6000	5'	3'					29	4400	4300	97
TQF 070 1_7	60	90	160	3500	6000	5'	3'	29	4400	4300	97	-	0.68	0.71	0.85
TQF 070 1_10	40	60	110	3500	6000	5'	3'	29	4400	4300	97	-	0.59	0.62	0.75
TQF 070 2_16	70	100	180	3500	6000	7'	5'	29	4400	4300	94	0.31	0.43	0.46	-
TQF 070 2_20	70	100	180	3500	6000	7'	5'	29	4400	4300	94	0,30	0.41	0.45	-
TQF 070 2_25	70	100	180	3500	6000	7'	5'	29	4400	4300	94	0.26	0.37	0.41	-
TQF 070 2_28	70	100	180	3500	6000	7'	5'	29	4400	4300	94	0.23	0.35	0.38	-
TQF 070 2_35	70	100	180	3500	6000	7'	5'	29	4400	4300	94	0.23	0.34	0.38	-
TQF 070 2_40	70	100	180	3500	6000	7'	5'	29	4400	4300	94	0.21	0.33	0.36	-
TQF 070 2_50	70	100	180	3500	6000	7'	5'	29	4400	4300	94	0.21	0.32	0.36	-
TQF 070 2_70	60	90	160	4000	6000	7'	5'	29	4400	4300	94	0.21	0.32	0.36	-
TQF 070 2_100	40	60	110	4500	6000	7'	5'	29	4400	4300	94	0.21	0.32	0.36	-

TQF 090

60A4 ... 180A

TQF

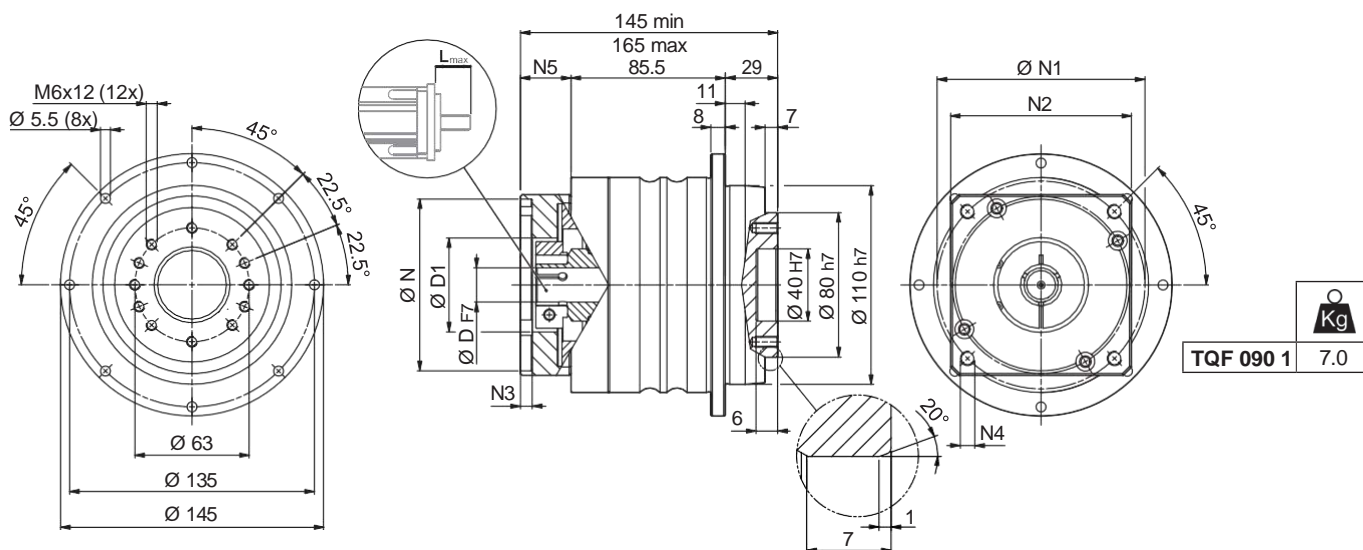

50C2 ... 130A

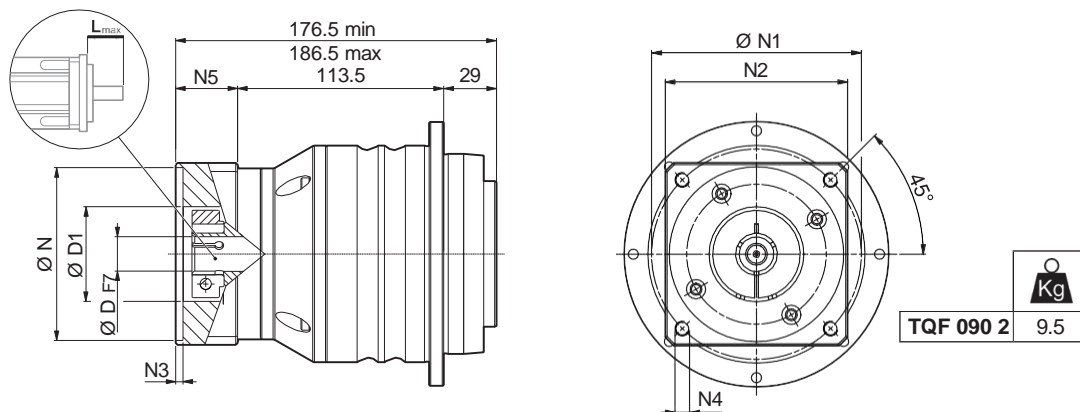

							N	N1	N2	N3	N4	N5	L _{max}
TQF 090 1													
60A4	11	14	19	-	-	-	60	75	100	6.5	M5x14	28	60
80A3	11	14	19	-	-	-	80	100	100	6.5	M6x16	28	60
95A2	11	14	19	24	28	-	95	115	100	6.5	M8x18	28	60
110A2	11	14	19	24	-	-	110	130	115	6.5	M8x18	28	60
110B1	11	14	19	24	-	-	110	145	120	6.5	M8x20	38	60
130A1	11	14	19	24	28	32	130	165	140	6.5	M10x25	38	60
180A	11	14	19	24	28	32	180	215	190	6.5	M14x28	48	80
TQF 090 2													
50C2	11	14	-	-	-	-	50	70	80	4	M4x10	34	50
60A3	11	14	19	-	-	-	60	75	80	4	M5x16	34	50
70B2	11	14	19	-	-	-	70	90	80	4	M5x16	34	50
80A2	11	14	19	-	-	-	80	100	90	4	M6x16	34	50
95A1	11	14	19	24	-	-	95	115	100	6.5	M8x20	34	50
110A1	11	14	19	24	-	-	110	130	115	6.5	M8x20	34	50
110B1	11	14	19	24	-	-	110	145	120	6.5	M8x20	44	60
130A	11	14	19	24	-	-	130	165	140	6.5	M10x19	34	50

Please contact us for different motor adapters and input shaft bore.

TQF 090

FM

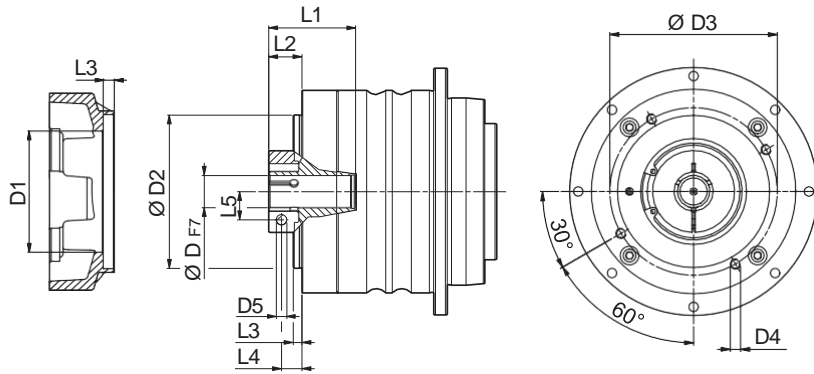

TQF

	D1	D2	D3	D4	D5	L1	L2	L3	L4	L5
TQF 090 1										
11	49	90	98	M6x12	M6	50	17	4	9.5	12.5
14	51	90	98	M6x12	M6	50	17	4	9.5	14.5
19	51	90	98	M6x12	M6	50	17	4	9.5	16.5
24	60	90	98	M6x12	M6	51.5	18.5	4	9.5	19
28	72	90	98	M6x12	M8	51.5	18.5	4	9.5	22.5
32	72	90	98	M6x12	M8	51.5	21	5	12	24.5
TQF 090 2										
6	37	68	76.5	M6x14	M4	45	25	9	19	8
9	49	68	76.5	M6x14	M5	42	25	9	18.5	10.5
11	51	68	76.5	M6x14	M6	42	25	9	17.5	12.5
14	51	68	76.5	M6x14	M6	42	25	9	17.5	14.5
19	51	68	76.5	M6x14	M6	42	25	9	17.5	16.5
24	60	68	76.5	M6x14	M6	43.5	26.5	9	17.5	19

	M_{n2}	M_{a2}	M_{p2}	n_1	$n_{1\ max}$	ϕ		C_t	$R_{2\ max}$	$A_{2\ max}$	η	J_G [kgcm ²]				
						ϕ_S	ϕ_R									
i	[Nm]	[Nm]	[Nm]	[min ⁻¹]	[min ⁻¹]	≤ [arcmin]		$\frac{Nm}{arcmin}$	[N]	[N]	%	11	14 - 19	24	28	32
TQF 090 1_4	200	300	500	2500	4500	5'	3'	70	5500	6800	97	-	2,00	2.12	2.51	4,30
TQF 090 1_5	180	280	500	2500	4500	5'	3'	70	5500	6800	97	-	1.63	1.76	2.14	3.94
TQF 090 1_7	160	250	500	3000	4500	5'	3'	70	5500	6800	97	-	1.31	1.44	1.82	3.62
TQF 090 1_10	110	170	350	3000	4500	5'	3'	70	5500	6800	97	-	1.14	1.27	1.65	3.45
TQF 090 2_16	200	300	500	3000	4500	7'	5'	70	5500	6800	94	0.75	0.85	0.98	-	-
TQF 090 2_20	180	280	500	3000	4500	7'	5'	70	5500	6800	94	0.72	0.82	0.96	-	-
TQF 090 2_25	180	280	500	3000	4500	7'	5'	70	5500	6800	94	0.62	0.72	0.85	-	-
TQF 090 2_28	200	300	500	3000	4500	7'	5'	70	5500	6800	94	0.54	0.64	0.77	-	-
TQF 090 2_35	180	280	500	3000	4500	7'	5'	70	5500	6800	94	0.53	0.63	0.76	-	-
TQF 090 2_40	200	300	500	3000	4500	7'	5'	70	5500	6800	94	0.49	0.59	0.72	-	-
TQF 090 2_50	180	280	500	3500	4500	7'	5'	70	5500	6800	94	0.48	0.58	0.72	-	-
TQF 090 2_70	160	250	500	4000	4500	7'	5'	70	5500	6800	94	0.48	0.58	0.71	-	-
TQF 090 2_100	110	170	350	4000	4500	7'	5'	70	5500	6800	94	0.48	0.58	0.71	-	-

TQF 130

80A3 ... 180A1

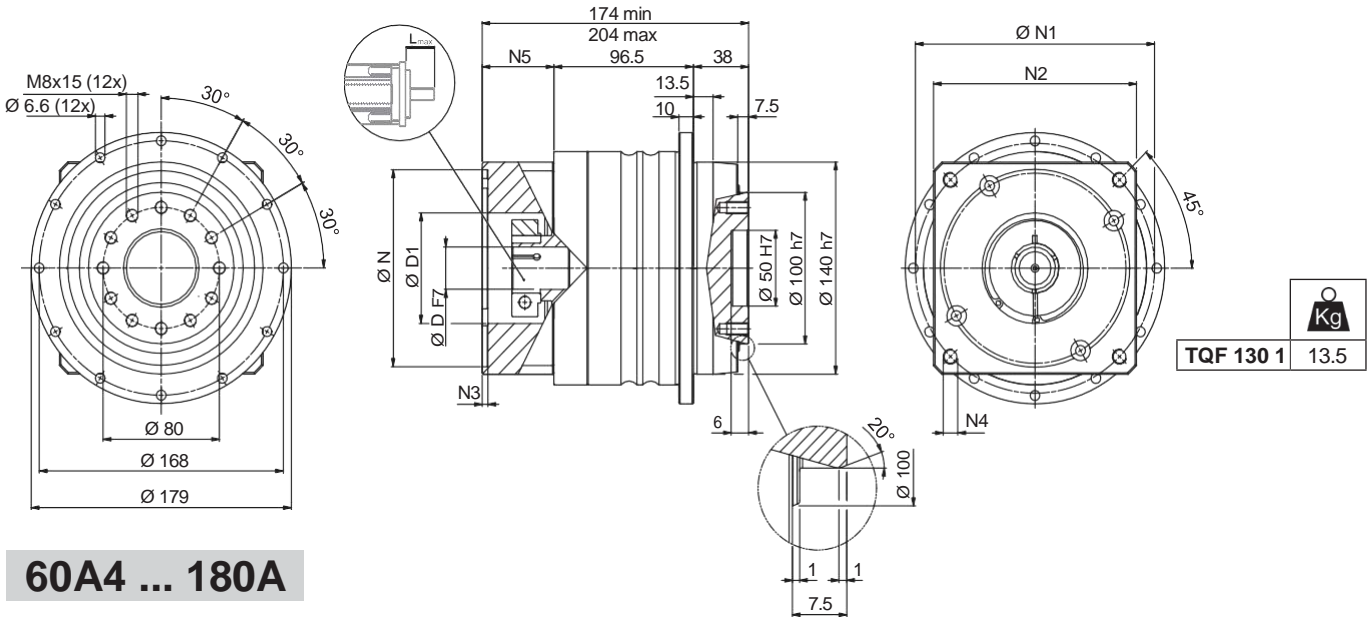

60A4 ... 180A

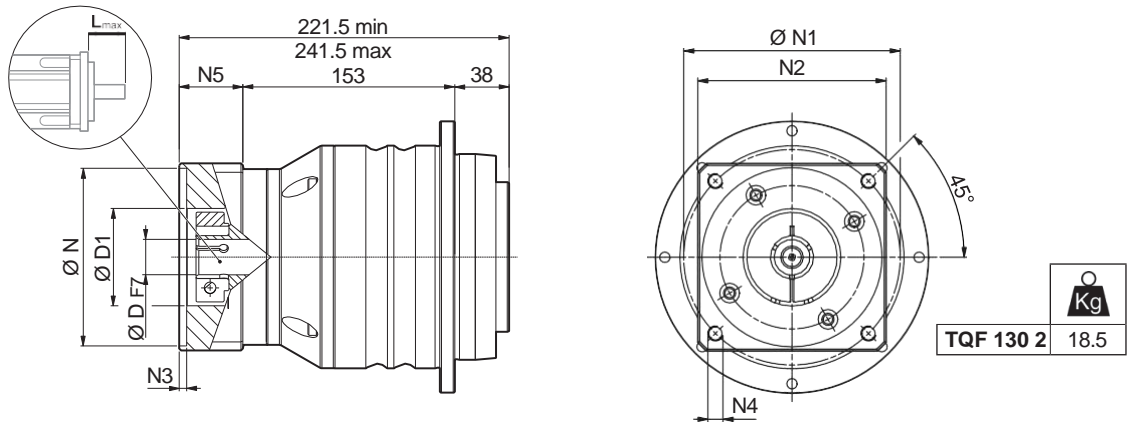

							N	N1	N2	N3	N4	N5	L _{max}
TQF 130 1													
80A3	14	19	-	-	-	-	80	100	130	4	M6x15	39.5	60
95A2	14	19	24	28	-	-	95	115	130	6.5	M8x20	39.5	60
110A2	14	19	24	-	-	-	110	130	130	4	M8x20	39.5	60
110B1	14	19	24	-	-	-	110	145	130	6.5	M8x20	49.5	60
130A1	14	19	24	28	32	-	130	165	140	4	M10x20	39	60
180A	14	19	24	28	32	-	180	215	190	5.5	M14x25	49.5	60
180A1	14	19	24	28	32	38	180	215	190	5.5	M14x25	69.5	80
TQF 130 2													
60A4	14	19	-	-	-	-	60	75	100	6.5	M5x14	28	60
80A3	14	19	-	-	-	-	80	100	100	6.5	M6x16	28	60
95A2	14	19	24	28	-	-	95	115	100	6.5	M8x18	28	60
110A2	14	19	24	-	-	-	110	130	115	6.5	M8x18	28	60
110B1	14	19	24	28	-	-	110	145	120	6.5	M8x20	38	60
130A1	14	19	24	28	32	-	130	165	140	6.5	M10x25	38	60
180A	14	19	24	28	32	-	180	215	190	6.5	M14x28	48	80

Please contact us for different motor adapters and input shaft bore.

TQF 130

FM

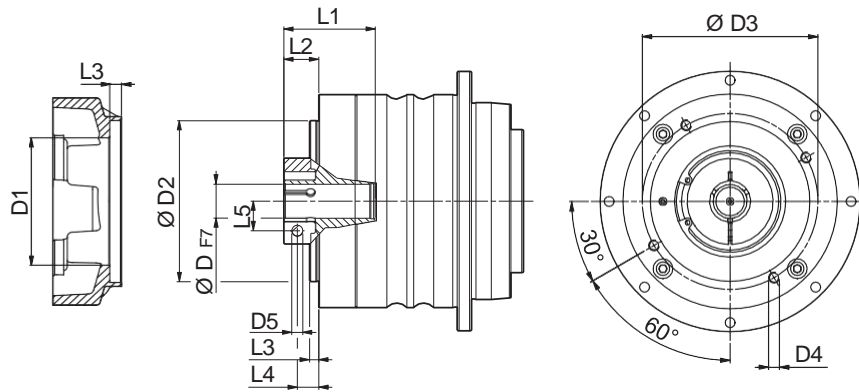

TQF

	D1	D2	D3	D4	D5	L1	L2	L3	L4	L5
TQF 130 1										
14	51	113	125.5	M8x16	M6	50	27.5	5	23	14.5
19	54	113	125.5	M8x16	M6	50	27.5	5	20	16.5
24	70	113	125.5	M8x16	M6	51.5	29	5	20	19
28	70	113	125.5	M8x16	M8	51.5	29	5	20	22.5
32	72	113	125.5	M8x16	M8	51.5	29	5	20	24.5
38	100	113	125.5	M8x16	M8	54	31.5	5	20	28
TQF 130 2										
11	49	90	98	M6x12	M6	50	17	4	9.5	12.5
14	51	90	98	M6x12	M6	50	17	4	9.5	14.5
19	51	90	98	M6x12	M6	50	17	4	9.5	16.5
24	60	90	98	M6x12	M6	51.5	18.5	4	9.5	19
28	72	90	98	M6x12	M8	51.5	18.5	4	9.5	22.5
32	72	90	98	M6x12	M8	51.5	21	5	12	24.5

	M_{n2}	M_{a2}	M_{p2}	n_1	n_{1max}	$\phi_S \leq \phi_R$		C_t	R_{2max}	A_{2max}	η	J_G [kgcm ²]			
						[Nm]	[Nm]					[Nm]	[min ⁻¹]	[min ⁻¹]	[arcmin]
TQF 130 1_4	400	600	1000	2100	4000	5'	3'	180	12000	8500	97	-	8.14	8.61	9.25
TQF 130 1_5	400	600	1000	2500	4000	5'	3'	180	12000	8500	97	-	6.13	6.59	7.24
TQF 130 1_7	360	550	950	2500	4000	5'	3'	180	12000	8500	97	-	4.40	4.86	5.50
TQF 130 1_10	280	420	900	2500	4000	5'	3'	180	12000	8500	97	-	3.43	3.89	4.53
TQF 130 2_16	400	600	1000	2800	4000	7'	5'	180	12000	8500	94	1.89	2.05	3.71	-
TQF 130 2_20	400	600	1000	2800	4000	7'	5'	180	12000	8500	94	1.77	1.92	3.58	-
TQF 130 2_25	400	600	1000	2800	4000	7'	5'	180	12000	8500	94	1.47	1.63	3.29	-
TQF 130 2_28	400	600	1000	2800	4000	7'	5'	180	12000	8500	94	1.26	1.41	3.07	-
TQF 130 2_35	400	600	1000	2800	4000	7'	5'	180	12000	8500	94	1.22	1.37	3.03	-
TQF 130 2_40	400	600	1000	3200	4000	7'	5'	180	12000	8500	94	1.10	1.25	2.91	-
TQF 130 2_50	400	600	1000	3200	4000	7'	5'	180	12000	8500	94	1.08	1.23	2.89	-
TQF 130 2_70	360	550	950	3500	4000	7'	5'	180	12000	8500	94	1.06	1.22	2.88	-
TQF 130 2_100	280	420	900	4000	4000	7'	5'	180	12000	8500	94	1.05	1.21	2.87	-

TQF 160

95A2 ... 180A1

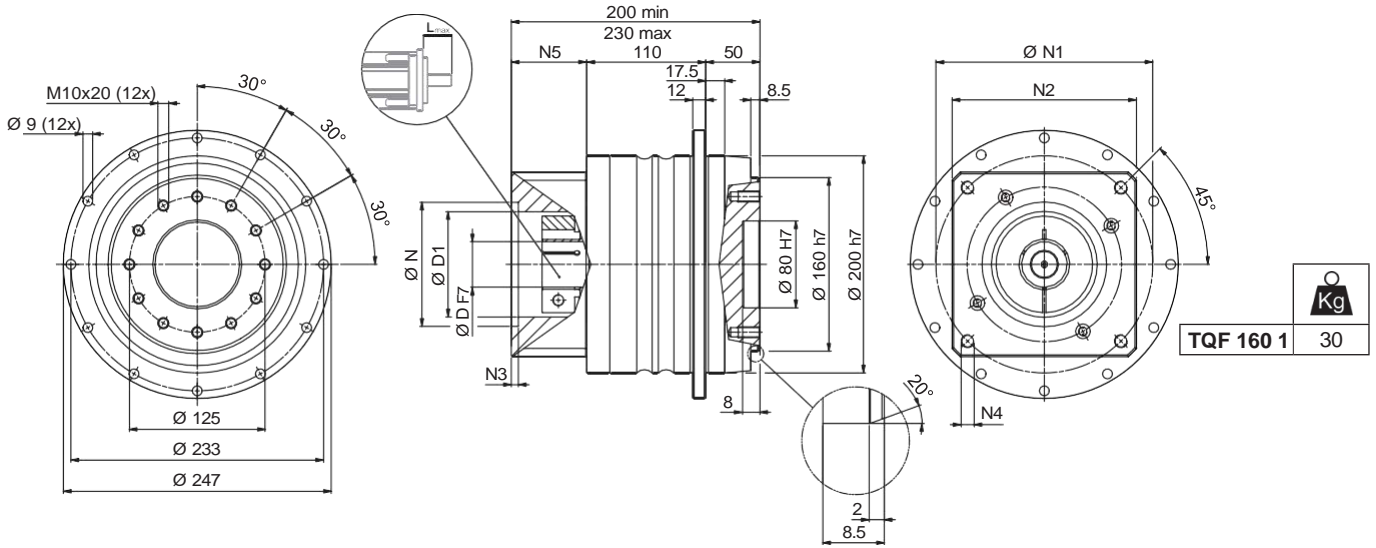

80A3 ... 180A1

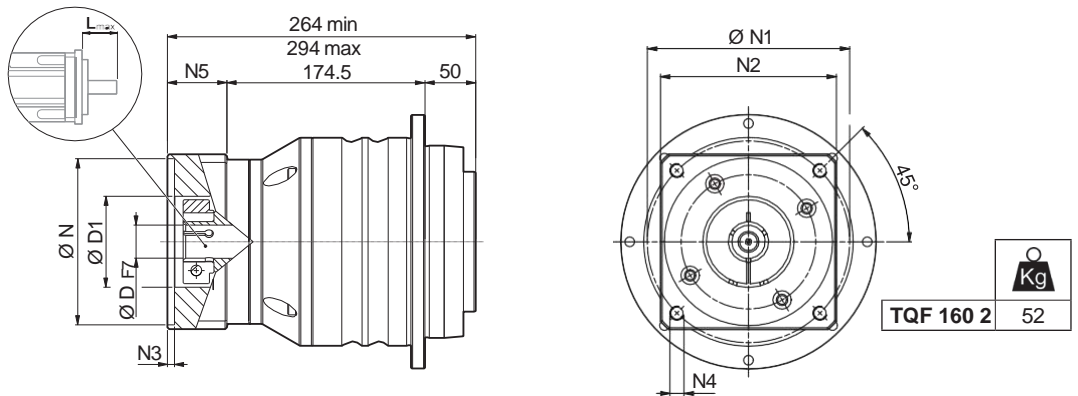

						N	N1	N2	N3	N4	N5	L _{max}
TQF 160 1												
95A2	19	24	28	-	-	95	115	140	6.5	M8x20	39.5	60
110A2	19	24	-	-	-	110	130	140	5	M8x20	39.5	60
130A1	19	24	28	32	-	130	165	140	5	M10x20	39.5	60
180A	-	24	28	32	-	180	215	190	6.5	M14x25	49.5	60
180A1	19	24	28	32	38	180	215	190	6.5	M14x25	69.5	80
TQF 160 2												
80A3	19	-	-	-	-	80	100	130	4	M6x15	39.5	60
95A2	19	24	28	-	-	95	115	130	6.5	M8x20	39.5	60
110A2	19	24	-	-	-	110	130	130	4	M8x20	39.5	60
110B1	19	24	28	-	-	110	145	130	6.5	M8x20	49.5	60
130A1	19	24	28	32	-	130	165	140	4	M10x20	39	60
180A	19	24	28	32	-	180	215	190	5.5	M14x25	49.5	60
180A1	19	24	28	32	38	180	215	190	5.5	M14x25	69.5	80

Please contact us for different motor adapters and input shaft bore.

TQF 160

FM

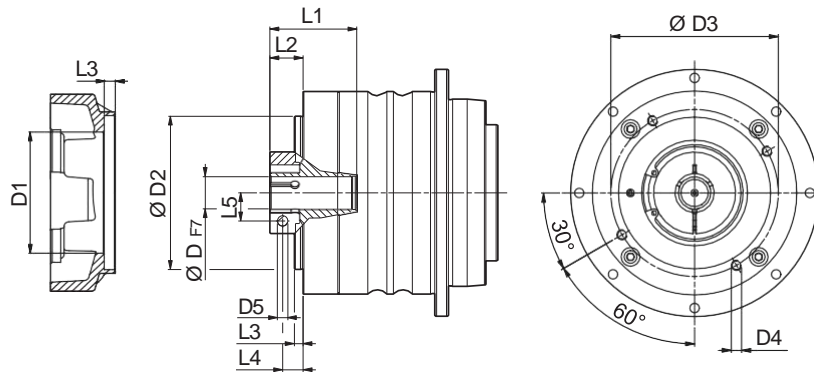

TQF

	D1	D2	D3	D4	D5	L1	L2	L3	L4	L5
TQF 160 1										
19	54	130	142.5	M8x16	M6	47	35.1	8	26	16.5
24	58	130	142.5	M8x16	M6	47	35.1	8	26	19
28	70	130	142.5	M8x16	M8	47	35.1	8	26	22.5
32	72	130	142.5	M8x16	M8	47	35.1	8	26	24.5
38	100	130	142.5	M8x16	M8	59.5	37.6	8	26	28
TQF 160 2										
14	51	113	125.5	M8x16	M6	50	27.5	5	23	14.5
19	54	113	125.5	M8x16	M6	50	27.5	5	20	16.5
24	70	113	125.5	M8x16	M6	51.5	29	5	20	19
28	70	113	125.5	M8x16	M8	51.5	29	5	20	22.5
32	72	113	125.5	M8x16	M8	51.5	29	5	20	24.5
38	100	113	125.5	M8x16	M8	54	31.5	5	20	28

	M_{n2} [Nm]	M_{a2} [Nm]	M_{p2} [Nm]	n_1 [min ⁻¹]	n_{1max} [min ⁻¹]	ϕ_S [arcmin]	ϕ_R [arcmin]	C_t [Nm/arcmin]	R_{2max} [N]	A_{2max} [N]	η %	J_G [kgcm ²]		
												19	24 - 28	32 - 38
TQF 160 1_4	800	1200	2000	1500	3500	5'	3'	500	29000	16000	97	-	27,10	27.51
TQF 160 1_5	800	1200	2000	1800	3500	5'	3'	500	29000	16000	97	-	18.22	18.63
TQF 160 1_7	750	1150	2000	2500	3500	5'	3'	500	29000	16000	97	-	13.46	13.87
TQF 160 1_10	550	850	1600	2500	3500	5'	3'	500	29000	16000	97	-	10.03	10.44
TQF 160 2_16	800	1200	2000	2800	3500	7'	5'	500	29000	16000	94	7.22	7.75	8.47
TQF 160 2_20	800	1200	2000	2800	3500	7'	5'	500	29000	16000	94	6.67	7,20	7.92
TQF 160 2_25	800	1200	2000	2800	3500	7'	5'	500	29000	16000	94	5.13	5.66	6.38
TQF 160 2_28	800	1200	2000	2800	3500	7'	5'	500	29000	16000	94	4,00	4.53	5.25
TQF 160 2_35	800	1200	2000	2800	3500	7'	5'	500	29000	16000	94	3.82	4.34	5.07
TQF 160 2_40	800	1200	2000	2800	3500	7'	5'	500	29000	16000	94	3.16	3.69	4.41
TQF 160 2_50	800	1200	2000	2800	3500	7'	5'	500	29000	16000	94	3.07	3,60	4.32
TQF 160 2_70	750	1150	2000	3000	3500	7'	5'	500	29000	16000	94	3.02	3.55	4.27
TQF 160 2_100	550	850	1600	3000	3500	7'	5'	500	29000	16000	94	2.99	3.52	4.24



TR Series

In addition to optimal performance, very low backlash, high overload capacity and easy installation, the TR series is characterized by great modularity due to multiple design configurations and wide ratios range, ensuring high reliability and the most fitting response to different applications requirements.

Other design versions

- K/G version



- MB version



Main benefits

- Very low backlash
- Great flexibility thanks to a wide range of gear ratios and multiple design configurations
- Great variety of input and output configurations

Main features

- Nominal output torque (Nm)



- Torsional backlash (arcmin)

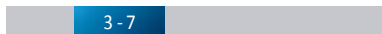

- Torsional stiffness (Nm/arcmin)

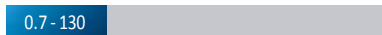

- Max tilting moment (Nm)



Protection class

- IP65

Frame sizes

- 053
- 060
- 080
- 105
- 130
- 160
- 190

Main options

- Design versions

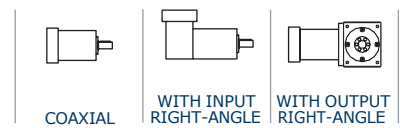

- Input versions

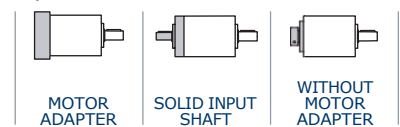

- Output shafts versions

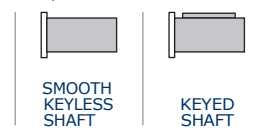

- Service type



- Lubrication



- Bearings versions



5 FEATURES OF TR SERIES

Planetary gear units of the TR series belong to a range of low backlash drives very broad and complete as far as transmissible torque, gear ratios and torsional backlash.

All units are generously proportioned to run quietly and provide a long service life without maintenance requirements.

Motor mounting is an operation that can be easily conducted without the need of any particular tooling, other than that usually available in a normally equipped workshop.

- Available with either standard (STD) or reduced (LOW) backlash:
 - 1-stage units: standard $\phi_s \leq 5'$; reduced $\phi_R \leq 3'$
 - 2-stage units: standard $\phi_s \leq 5'$; reduced $\phi_R \leq 3'$
 - 3-stage units (G and MB only): standard $\phi_R \leq 5'$; reduced $\phi_R \leq 3'$
 - 3-stage units: standard $\phi_s \leq 7'$; reduced $\phi_R \leq 5'$
 - 4-stage units (G and MB only): standard $\phi_s \leq 7'$; reduced $\phi_R \leq 5'$
- A high IP rating (IP65) provides inner parts with protection against the ingress of dust and liquids.
- Fluoroelastometer oils seals are supplied for S1 duty.
- Noise pressure level $L_p \leq 70$ dB(A). Conditions: distance 1 m; measured without load an input speed of $n_1 = 3000 \text{ min}^{-1}$; $i=10$.
- Bearings suitably rated for an average service life of 20,000 hours under nominal operating conditions. The following chart shows the types of bearings for the output shaft.

	TR 053	TR 060	TR 080	TR 105	TR 130	TR 160	TR 190
SB							

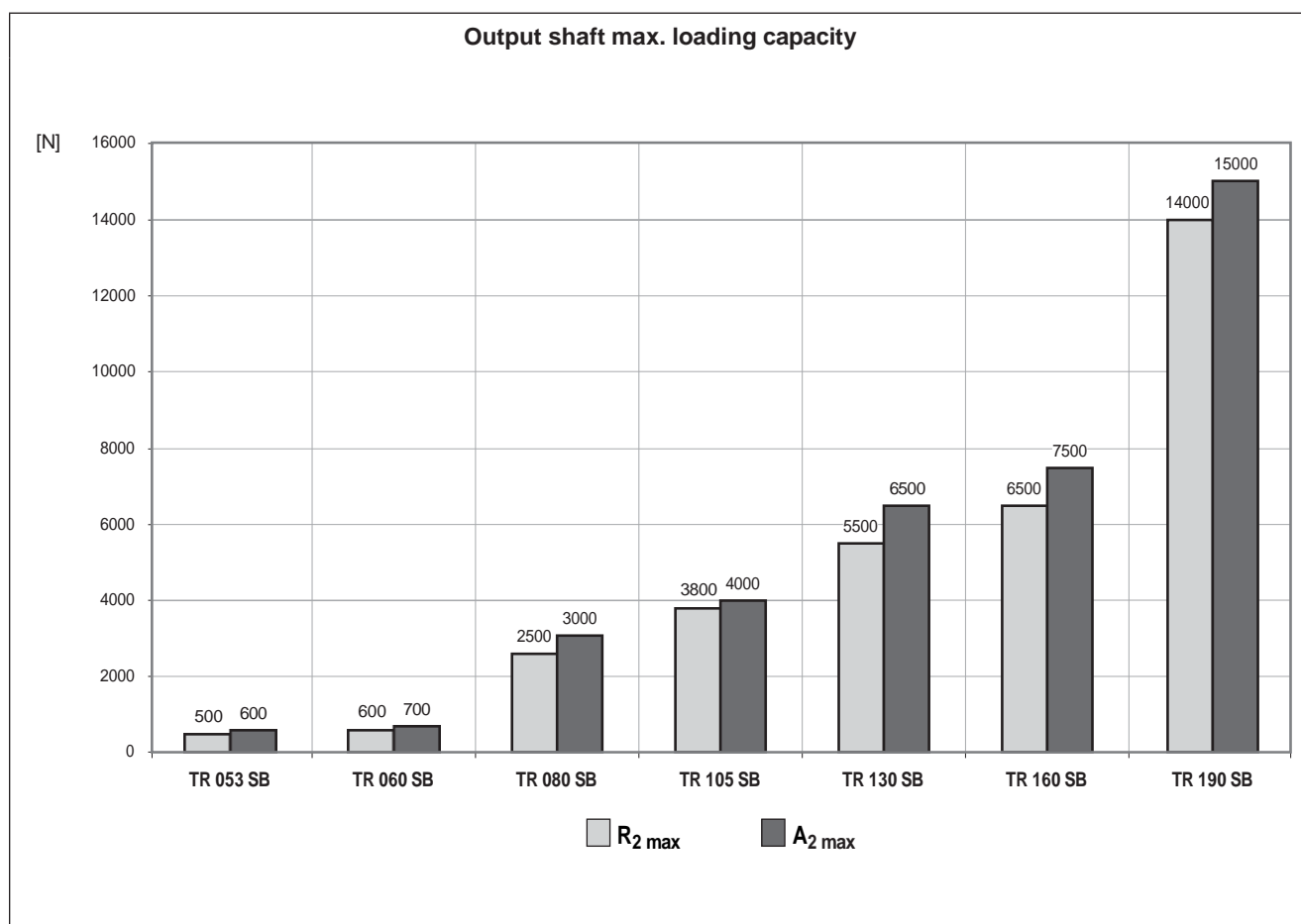

- Wide range of adapter flanges matching the most popular brands of motors.

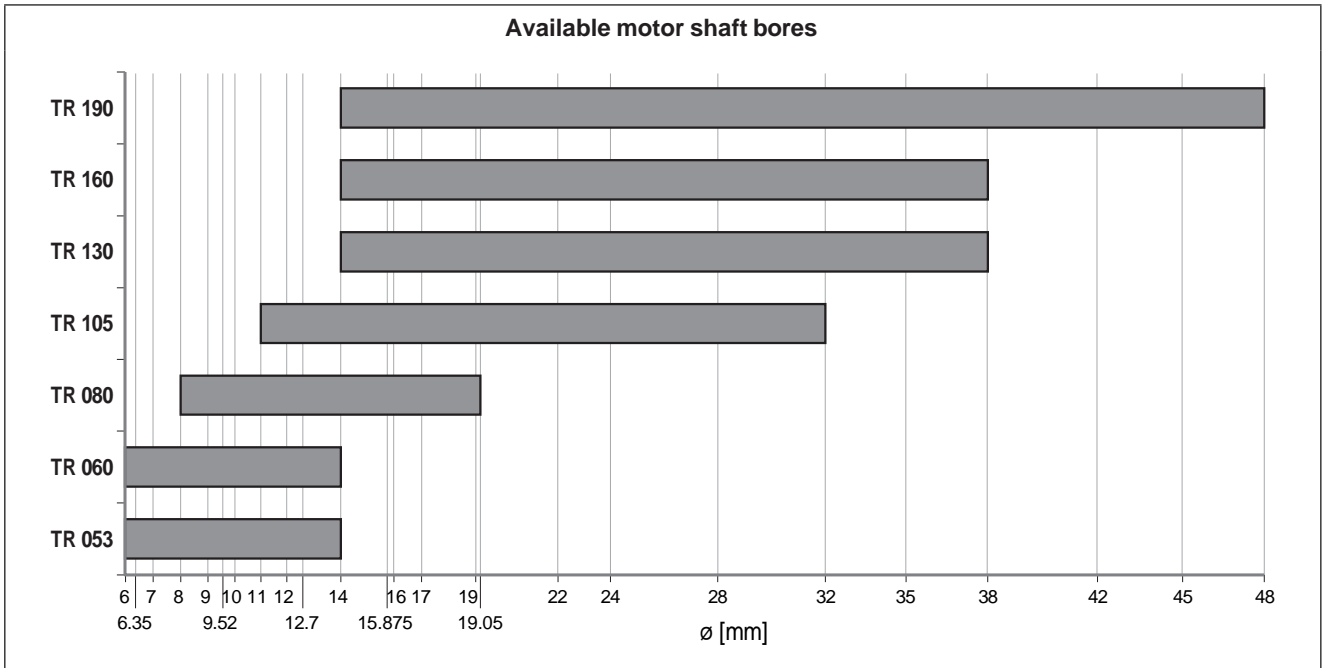

- Lubrication optimized for the type of duty specified when ordering.
In the absence of contamination the lubricant requires no periodical changes.

duty	TR 053 - TR 060	TR 080 ... TR 190	oil seals
S1 (continuous)	NLGI grease consistency 00	Synthetic oil viscosity ISO VG 220	Fluoroelastomer
S5 (intermittent)		NLGI grease consistency 00	NBR

- Ambient temperature min -20°C, max +30°C. For temperature higher than 30°C please consider derating factor f_T .
- Housing temperature must not exceed $T_{max} = 90^\circ\text{C}$.

		Distribution of nominal torque M_{n2} [Nm]																											
	[I]	3	4	5	6	7	9	10	12	15	16	20	25	28	30	35	36	40	45	48	50	60	64	70	75	80	81	84	90
TR 053		12	15	15	15	15	12	-	20	20	20	20	20	20	-	20	15	-	20	20	-	20	20	-	20	20	12	20	-
TR 060		18	25	25	25	25	18	18	30	30	30	30	30	30	18	30	25	30	-	30	30	-	30	30	30	30	-	30	18
TR 080		40	50	50	50	50	40	40	70	70	70	70	70	70	40	70	50	70	-	70	70	-	70	70	70	70	-	70	40
TR 105		100	140	140	140	140	100	100	170	170	170	170	170	170	100	170	140	170	-	170	170	-	170	170	170	170	-	170	100
TR 130		215	380	380	380	380	215	215	450	450	450	450	450	450	215	450	380	450	-	450	450	-	450	450	450	450	-	450	215
TR 160		350	500	500	500	500	350	350	700	700	700	700	700	700	350	700	500	700	-	700	700	-	700	700	700	700	-	700	350
TR 190		500	700	700	700	700	500	500	1000	1000	1000	1000	1000	1000	500	1000	700	1000	-	1000	1000	-	1000	1000	1000	1000	-	1000	500
	[II]	100	112	120	125	140	144	150	160	175	180	200	210	216	225	245	250	252	280	324	350	400	405	500	567	700	729	1000	
TR 053		20	20	-	20	20	20	-	-	20	20	-	-	20	20	20	-	20	-	20	-	-	20	-	20	-	12	-	
TR 060		18	-	30	30	30	-	30	30	30	-	30	30	30	-	-	30	-	30	-	30	30	-	30	-	30	-	18	
TR 080		40	-	70	70	70	-	70	70	70	-	70	70	70	-	-	70	-	70	-	70	70	-	70	-	70	-	40	
TR 105		100	-	170	170	170	-	170	170	170	-	170	170	170	-	-	170	-	170	-	170	170	-	170	-	170	-	100	
TR 130		215	-	450	450	450	-	450	450	450	-	450	450	450	-	-	450	-	450	-	450	450	-	450	-	450	-	215	
TR 160		700	-	350	700	700	-	700	700	700	-	700	700	-	-	700	-	700	-	700	700	-	700	700	-	700	-	350	
TR 190		1000	-	500	1000	1000	-	1000	1000	1000	-	1000	1000	-	-	1000	-	1000	-	1000	1000	-	1000	1000	-	1000	-	500	

5.1 ORDERING CODE

TR

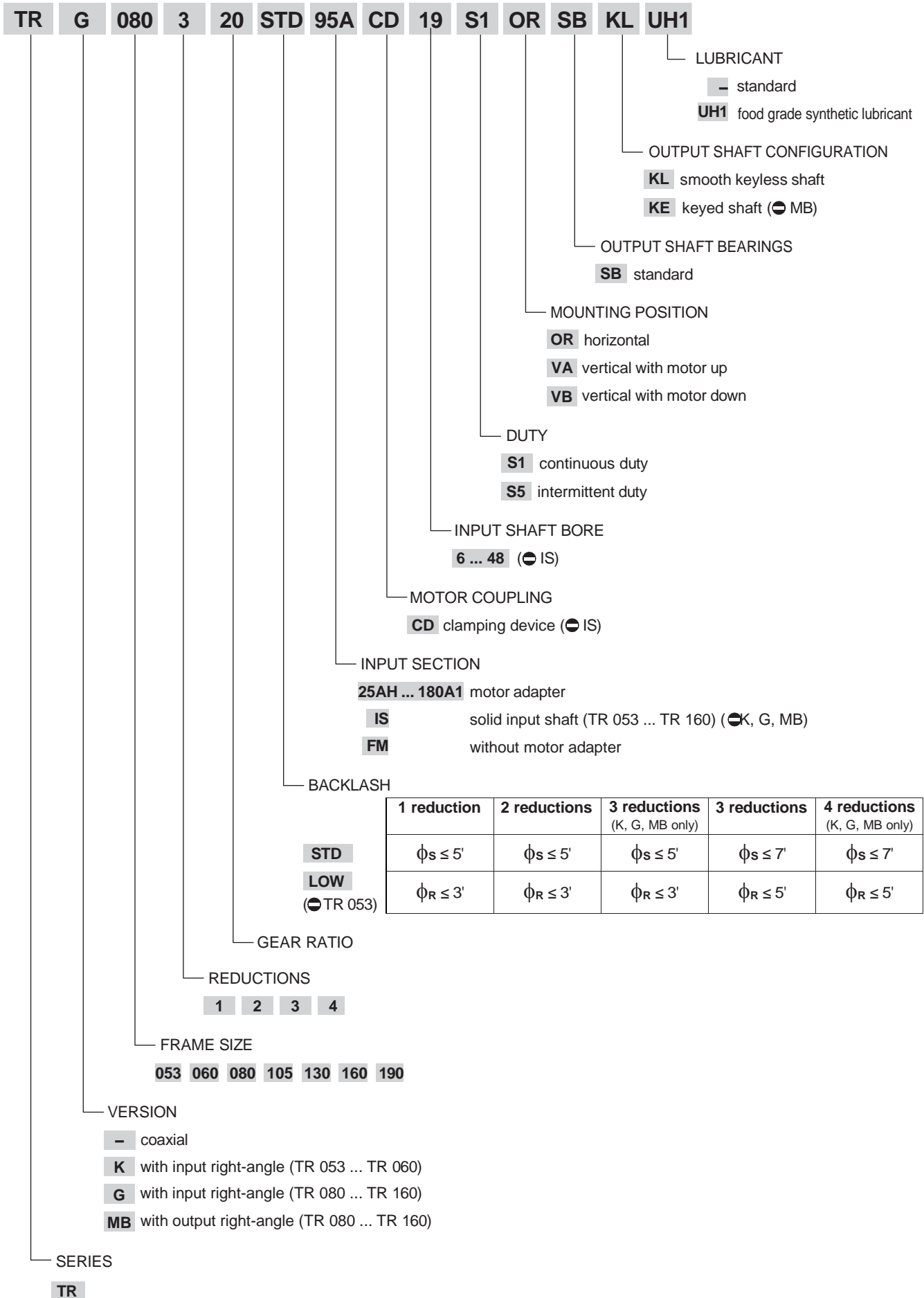

5.1.1 VERSION AND INPUT SECTION

INPUT SECTION	VERSION		
	coaxial (—)	with input right-angle (K - G)	with output right-angle (MB)
25AH ... 180A1			
IS			
FM			

5.1.2 MOUNTING POSITIONS

	OR	VA	VB
—			
K - G			
MB			

5.1.3 ADMISSIBLE RADIAL AND AXIAL FORCES FOR MB VERSION

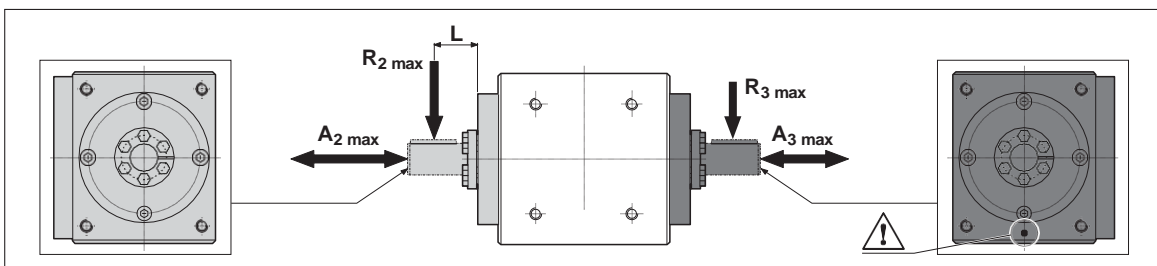

	$R_2 \text{ max}$ [N]	$A_2 \text{ max}$ [N]	L [mm]	$R_3 \text{ max}$ [N]	$A_3 \text{ max}$ [N]
TR MB 080	6000	5000	60	5500	5000
TR MB 105	9000	7500	80	7500	7500
TR MB 130	13500	11500	100	11000	11500
TR MB 160*	15000	11500	100	12500	11500

* Bearings suitably rated for an average service life of 10,000 hours under nominal operating conditions.

5.2 DIMENSIONS AND TECHNICAL SPECIFICATIONS

TR 053

IS

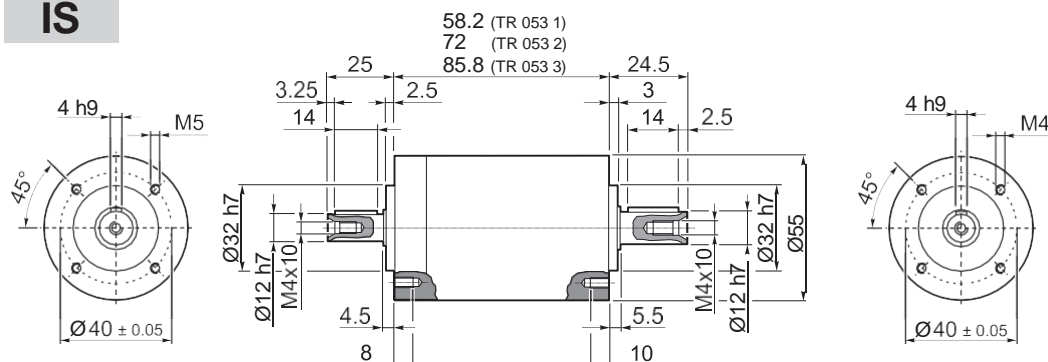

TR 053 1	0.8
TR 053 2	1.0
TR 053 3	1.3

TR

25AH ... 80A

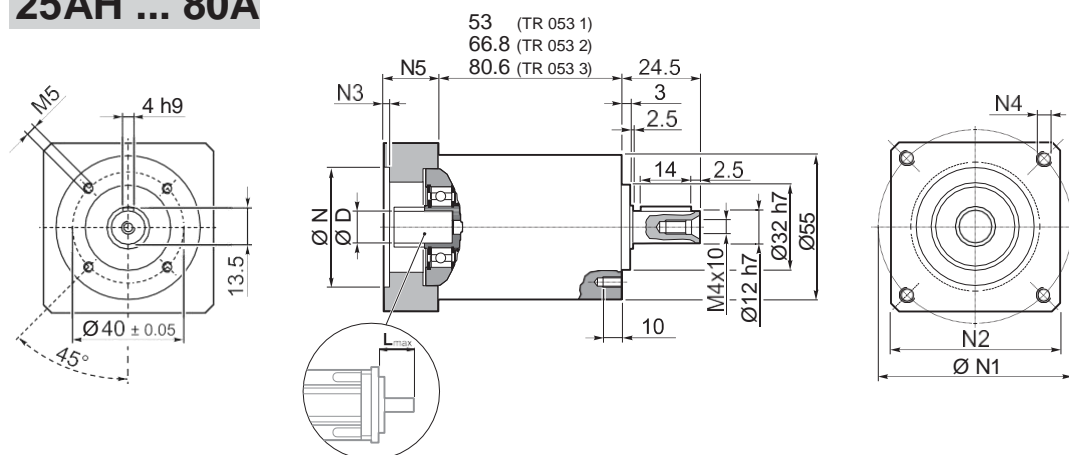

TR 053 1	0.8
TR 053 2	1.0
TR 053 3	1.3

	D											N	N1		N2	N3	N4	N5	L _{max}
	6	6.35	7	8	9	9.52	-	-	-	-	-		min	max					
25AH	6	6.35	7	8	9	9.52	-	-	-	-	-	25	36	48					
26AH	6	6.35	7	8	9	9.52	-	-	-	-	-	26	36	48					
28AH	6	6.35	7	8	9	9.52	-	-	-	-	-	28	36	48					
30AH	6	6.35	7	8	9	9.52	-	-	-	-	-	30	36	48					
32AH	6	6.35	7	8	9	9.52	-	-	-	-	-	32	38	48	55	3.5	4.5	25	25
34AH	6	6.35	7	8	9	9.52	-	-	-	-	-	34	40	48					
36AH	6	6.35	7	8	9	9.52	-	-	-	-	-	36	42	48					
38AH	6	6.35	7	8	9	9.52	-	-	-	-	-	38	44	48					
40AH	6	6.35	7	8	9	9.52	-	-	-	-	-	40	46	48					
38B	6	6.35	7	8	9	9.52	10	11	12	12.7	-	38.1	66.6		60	3	M4x10	18	25
40B	6	6.35	7	8	9	9.52	10	11	12	12.7	-	40	63		60	3	M4x10	18	25
50A	6	6.35	7	8	9	9.52	10	11	12	12.7	-	50	60		60	3	M4x10	18	25
50B	6	6.35	7	8	9	9.52	10	11	12	12.7	14	50	65		60	3	M5x12	23	30
50BH	6	6.35	7	8	9	9.52	10	11	12	12.7	14	50	65		60	4	5.5	23	30
50C	6	6.35	7	8	9	9.52	10	11	12	12.7	14	50	70		60	3	M4x10	23	30
50MH	6	6.35	7	8	9	9.52	10	11	12	12.7	-	50	65		55	2	5.5	16	23
60A	6	6.35	7	8	9	9.52	10	11	12	12.7	-	60	75		65	3	M5x12	18	25
60AH	6	6.35	7	8	9	9.52	10	11	12	12.7	-	60	75		65	3	5.5	18	25
60A1	6	6.35	7	8	9	9.52	10	11	12	12.7	14	60	75		65	3	M5x12	23	30
60AH1	6	6.35	7	8	9	9.52	10	11	12	12.7	14	60	75		65	3	5.5	23	30
60B	6	6.35	7	8	9	9.52	10	11	12	12.7	14	60	85		75	3	M5x12	23	30
60C	6	6.35	7	8	9	9.52	10	11	12	12.7	14	60	90		75	3	M5x12	23	30
70A	6	6.35	7	8	9	9.52	10	11	12	12.7	14	70	85		75	3	M6x15	23	30
70B	6	6.35	7	8	9	9.52	10	11	12	12.7	14	70	90		75	5	M5x12	23	30
73A	6	6.35	7	8	9	9.52	10	11	12	12.7	14	73	98.4		85	3	M5x12	25	32
80A	6	6.35	7	8	9	9.52	10	11	12	12.7	14	80	100		85	3	M6x15	23	30

TR 053

FM

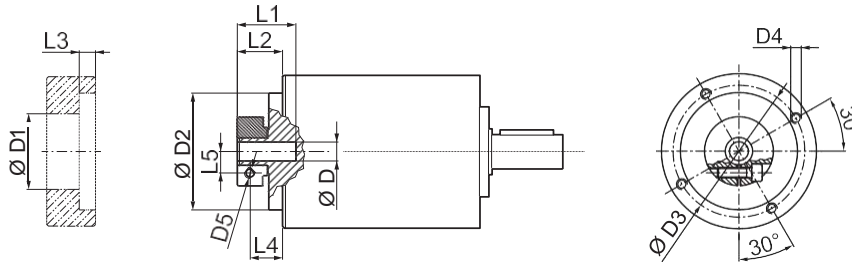

				D1	D2	D3	D4	D5	L1	L2	L3	L4	L5
6	6.35	7		32.5	50	42.5	M4x8	M4	20.2	13.2	3	8.7	8
8	9	9.52	10	32.5	50	42.5	M4x8	M4	20.2	13.2	3	7.8	9
11	12	12.7		35.5	50	42.5	M4x8	M4	20.5	13.5	3	8.5	11
14				35.5	50	42.5	M4x8	M4	24	17	3	10.2	11.5

	i	M_{n2}	M_{a2}	M_{p2}	n_1	$n_{1\max}$	ϕ_s	C_t	$R_{1\max}$	$R_{2\max}$	$A_{2\max}$	η	J_G [kgcm ²]	
		[Nm]	[Nm]	[Nm]	[min ⁻¹]	[min ⁻¹]	[arcmin]	$\frac{Nm}{arcmin}$	[N]	[N]	[N]	%		6 ... 9.52
TR 053 1_3		12	22	40	3300	4000	5'	1.0	200	500	600	97	0.06	0.08
TR 053 1_4		15	28	45	3500	5000	5'	1.0	200	500	600	97	0.05	0.06
TR 053 1_5		15	28	45	3500	5000	5'	1.0	200	500	600	97	0.04	0.06
TR 053 1_6		15	28	45	3500	5000	5'	1.0	200	500	600	97	0.03	0.05
TR 053 1_7		15	28	45	4000	6000	5'	1.0	200	500	600	97	0.03	0.05
TR 053 1_9		12	22	40	4000	6000	5'	1.0	200	500	600	97	0.03	0.05
TR 053 2_12		20	30	60	3300	4000	5'	0.9	200	500	600	94	0.06	0.08
TR 053 2_15		20	30	60	3300	4000	5'	0.9	200	500	600	94	0.06	0.08
TR 053 2_16		20	30	60	3500	5000	5'	0.9	200	500	600	94	0.05	0.06
TR 053 2_20		20	30	60	3500	5000	5'	0.9	200	500	600	94	0.04	0.06
TR 053 2_25		20	30	60	3500	5000	5'	0.9	200	500	600	94	0.04	0.06
TR 053 2_28		20	30	60	4000	6000	5'	0.9	200	500	600	94	0.03	0.05
TR 053 2_35		20	30	60	4000	6000	5'	0.9	200	500	600	94	0.03	0.05
TR 053 2_36		15	28	45	4000	6000	5'	0.9	200	500	600	94	0.03	0.05
TR 053 2_45		20	30	60	4000	6000	5'	0.9	200	500	600	94	0.03	0.05
TR 053 2_81		12	22	40	4000	6000	5'	0.9	200	500	600	94	0.03	0.05
TR 053 3_48		20	30	60	4000	5000	7'	0.7	200	500	600	91	0.05	0.07
TR 053 3_60		20	30	60	3500	5000	7'	0.7	200	500	600	91	0.05	0.07
TR 053 3_64		20	30	60	3500	5000	7'	0.7	200	500	600	91	0.05	0.06
TR 053 3_75		20	30	60	3500	5000	7'	0.7	200	500	600	91	0.04	0.06
TR 053 3_80		20	30	60	3500	5000	7'	0.7	200	500	600	91	0.05	0.06
TR 053 3_84		20	30	60	4000	6000	7'	0.7	200	500	600	91	0.03	0.05
TR 053 3_100		20	30	60	3500	5000	7'	0.7	200	500	600	91	0.04	0.06
TR 053 3_112		20	30	60	4000	6000	7'	0.7	200	500	600	91	0.03	0.05
TR 053 3_125		20	30	60	3500	5000	7'	0.7	200	500	600	91	0.04	0.06
TR 053 3_140		20	30	60	4000	6000	7'	0.7	200	500	600	91	0.03	0.05
TR 053 3_144		20	30	60	4000	6000	7'	0.7	200	500	600	91	0.03	0.05
TR 053 3_175		20	30	60	4000	6000	7'	0.7	200	500	600	91	0.03	0.05
TR 053 3_180		20	30	60	4000	6000	7'	0.7	200	500	600	91	0.03	0.05
TR 053 3_216		20	30	60	3500	5000	7'	0.7	200	500	600	91	0.03	0.05
TR 053 3_225		20	30	60	4000	6000	7'	0.7	200	500	600	91	0.03	0.05
TR 053 3_245		20	30	60	4000	6000	7'	0.7	200	500	600	91	0.03	0.05
TR 053 3_252		20	30	60	4000	6000	7'	0.7	200	500	600	91	0.05	0.06
TR 053 3_324		20	30	60	4000	6000	7'	0.7	200	500	600	91	0.03	0.05
TR 053 3_405		20	30	60	4000	6000	7'	0.7	200	500	600	91	0.03	0.05
TR 053 3_567		20	30	60	4000	6000	7'	0.7	200	500	600	91	0.03	0.05
TR 053 3_729		12	22	40	4000	6000	7'	0.7	200	500	600	91	0.03	0.05

Please contact us for different motor adapters and input shaft bore.

TR K 053

25AH ... 80A

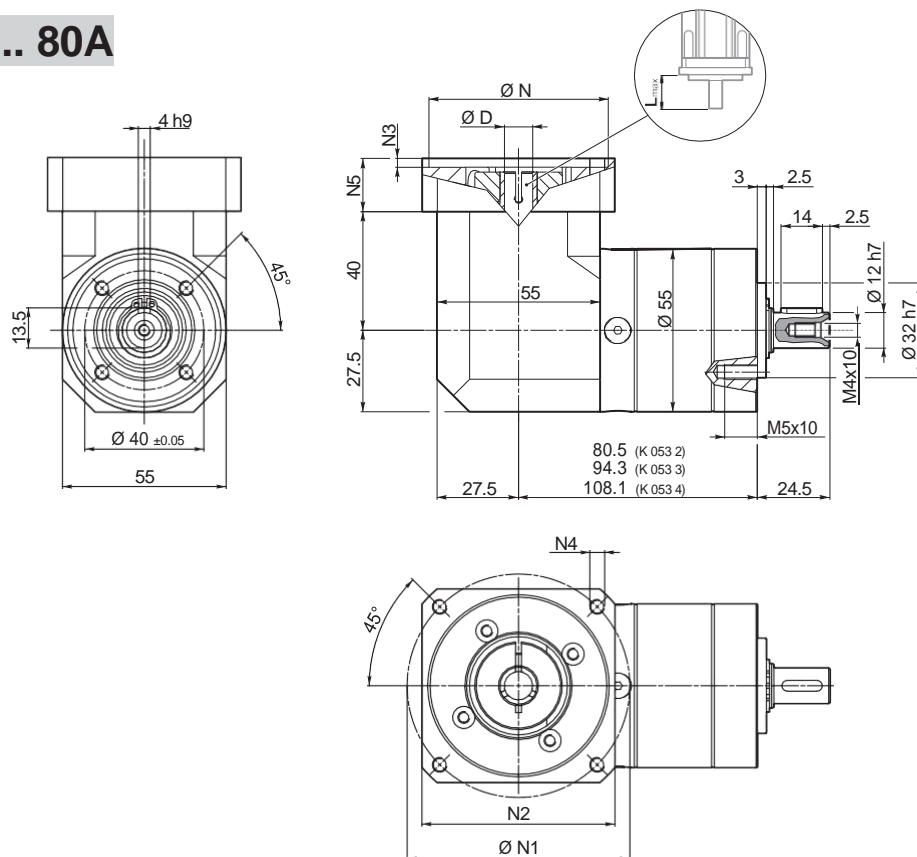

	TR K 053 2	1.3
	TR K 053 3	1.5
	TR K 053 4	1.8

TR

												N	N1		N2	N3	N4	N5	L _{max}
	D	6	6.35	7	8	9	9.52	10	11	12	12.7		min	max					
25AH		6	6.35	7	8	9	9.52	-	-	-	-	25	36	48					
26AH		6	6.35	7	8	9	9.52	-	-	-	-	26	36	48					
28AH		6	6.35	7	8	9	9.52	-	-	-	-	28	36	48					
30AH		6	6.35	7	8	9	9.52	-	-	-	-	30	36	48					
32AH		6	6.35	7	8	9	9.52	-	-	-	-	32	38	48	55	3.5	4.5	25	25
34AH		6	6.35	7	8	9	9.52	-	-	-	-	34	40	48					
36AH		6	6.35	7	8	9	9.52	-	-	-	-	36	42	48					
38AH		6	6.35	7	8	9	9.52	-	-	-	-	38	44	48					
40AH		6	6.35	7	8	9	9.52	-	-	-	-	40	46	48					
38B		6	6.35	7	8	9	9.52	10	11	12	12.7	38.1	66.6	60	3	M4x10	18	25	
40B		6	6.35	7	8	9	9.52	10	11	12	12.7	40	63	60	3	M4x10	18	25	
50A		6	6.35	7	8	9	9.52	10	11	12	12.7	50	60	60	3	M4x10	18	25	
50B		6	6.35	7	8	9	9.52	10	11	12	12.7	50	65	60	3	M5x12	23	30	
50BH		6	6.35	7	8	9	9.52	10	11	12	12.7	50	65	60	4	5.5	23	30	
50C		6	6.35	7	8	9	9.52	10	11	12	12.7	50	70	60	3	M4x10	23	30	
50MH		6	6.35	7	8	9	9.52	10	11	12	12.7	50	65	55	2	5.5	16	23	
60A		6	6.35	7	8	9	9.52	10	11	12	12.7	60	75	65	3	M5x12	18	25	
60A1		6	6.35	7	8	9	9.52	10	11	12	12.7	60	75	65	3	M5x12	23	30	
60B		6	6.35	7	8	9	9.52	10	11	12	12.7	60	85	75	3	M5x12	23	30	
60C		6	6.35	7	8	9	9.52	10	11	12	12.7	60	90	75	3	M5x12	23	30	
70A		6	6.35	7	8	9	9.52	10	11	12	12.7	70	85	75	3	M6x15	23	30	
70B		6	6.35	7	8	9	9.52	10	11	12	12.7	70	90	75	5	M5x12	23	30	
73A		6	6.35	7	8	9	9.52	10	11	12	12.7	73	98.4	85	3	M5x12	25	32	
80A		6	6.35	7	8	9	9.52	10	11	12	12.7	80	100	85	3	M6x15	23	30	

TR K 053

FM

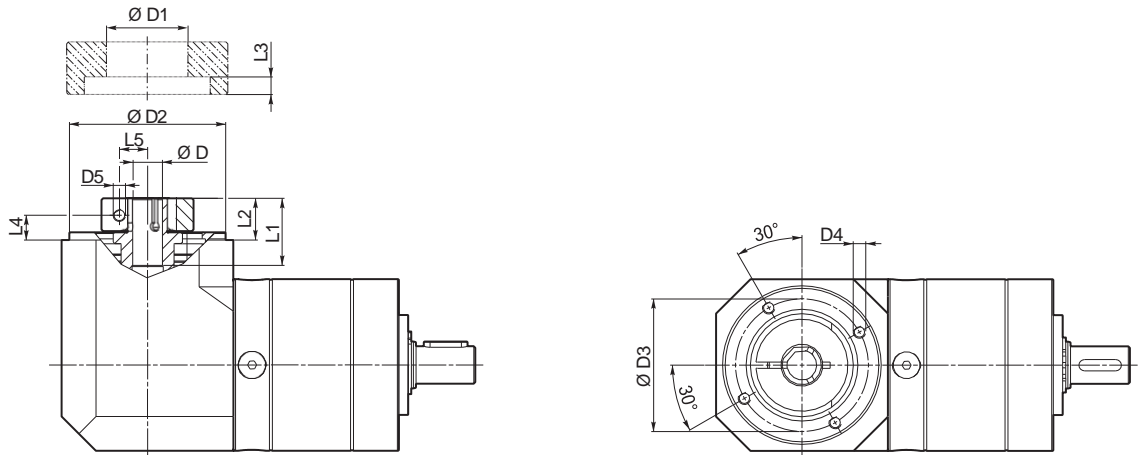

D				D1	D2	D3	D4	D5	L1	L2	L3	L4	L5
6	6.35	7		32.5	50	42.5	M4x8	M4	20.2	13.2	3	8.7	8
8	9	9.52	10	32.5	50	42.5	M4x8	M4	20.2	13.2	3	7.8	9
11	12	12.7		35.5	50	42.5	M4x8	M4	20.5	13.5	3	8.5	11
14				35.5	50	42.5	M4x8	M4	24	17	3	10.2	11.5

TR

i	M _{n 2}	M _{a 2}	M _{p 2}	n ₁	n _{1 max}	φ _S	C _t	R _{2 max}	A _{2 max}	η	J _G [kgcm ²]	
	[Nm]	[Nm]	[Nm]	[min ⁻¹]	[min ⁻¹]	[arcmin]	$\frac{Nm}{arcmin}$	[N]	[N]	%	D	
											6 ... 9.52	10 ... 14
TR K 053 2_3	12	22	40	3300	4000	5'	1.0	500	600	94	0.18	0.20
TR K 053 2_4	15	28	45	3500	5000	5'	1.0	500	600	94	0.18	0.19
TR K 053 2_5	15	28	45	3500	5000	5'	1.0	500	600	94	0.17	0.19
TR K 053 2_6	15	28	45	3500	5000	5'	1.0	500	600	94	0.17	0.18
TR K 053 2_7	15	28	45	4000	6000	5'	1.0	500	600	94	0.17	0.19
TR K 053 2_9	12	22	40	4000	6000	5'	1.0	500	600	94	0.17	0.18
TR K 053 3_12	20	30	60	3300	4000	5'	0.9	500	600	91	0.18	0.20
TR K 053 3_15	20	30	60	3300	4000	5'	0.9	500	600	91	0.18	0.20
TR K 053 3_16	20	30	60	3500	5000	5'	0.9	500	600	91	0.17	0.19
TR K 053 3_20	20	30	60	3500	5000	5'	0.9	500	600	91	0.17	0.19
TR K 053 3_25	20	30	60	3500	5000	5'	0.9	500	600	91	0.17	0.19
TR K 053 3_28	20	30	60	4000	6000	5'	0.9	500	600	91	0.17	0.19
TR K 053 3_35	20	30	60	4000	6000	5'	0.9	500	600	91	0.17	0.19
TR K 053 3_36	15	28	45	4000	6000	5'	0.9	500	600	91	0.17	0.18
TR K 053 3_45	20	30	60	4000	6000	5'	0.9	500	600	91	0.17	0.19
TR K 053 3_81	12	22	40	4000	6000	5'	0.9	500	600	91	0.17	0.18
TR K 053 4_48	20	30	60	4000	5000	7'	0.7	500	600	89	0.18	0.19
TR K 053 4_60	20	30	60	3500	5000	7'	0.7	500	600	89	0.18	0.19
TR K 053 4_64	20	30	60	3500	5000	7'	0.7	500	600	89	0.17	0.19
TR K 053 4_75	20	30	60	3500	5000	7'	0.7	500	600	89	0.17	0.19
TR K 053 4_80	20	30	60	3500	5000	7'	0.7	500	600	89	0.17	0.19
TR K 053 4_84	20	30	60	4000	6000	7'	0.7	500	600	89	0.17	0.19
TR K 053 4_100	20	30	60	3500	5000	7'	0.7	500	600	89	0.17	0.19
TR K 053 4_112	20	30	60	4000	6000	7'	0.7	500	600	89	0.17	0.19
TR K 053 4_125	20	30	60	3500	5000	7'	0.7	500	600	89	0.17	0.19
TR K 053 4_140	20	30	60	4000	6000	7'	0.7	500	600	89	0.17	0.19
TR K 053 4_144	20	30	60	4000	6000	7'	0.7	500	600	89	0.17	0.18
TR K 053 4_175	20	30	60	4000	6000	7'	0.7	500	600	89	0.17	0.19
TR K 053 4_180	20	30	60	4000	6000	7'	0.7	500	600	89	0.17	0.18
TR K 053 4_216	20	30	60	3500	5000	7'	0.7	500	600	89	0.17	0.18
TR K 053 4_225	20	30	60	4000	6000	7'	0.7	500	600	89	0.17	0.18
TR K 053 4_245	20	30	60	4000	6000	7'	0.7	500	600	89	0.17	0.19
TR K 053 4_252	20	30	60	4000	6000	7'	0.7	500	600	89	0.18	0.20
TR K 053 4_324	20	30	60	4000	6000	7'	0.7	500	600	89	0.17	0.18
TR K 053 4_405	20	30	60	4000	6000	7'	0.7	500	600	89	0.17	0.18
TR K 053 4_567	20	30	60	4000	6000	7'	0.7	500	600	89	0.17	0.18
TR K 053 4_729	12	22	40	4000	6000	7'	0.7	500	600	89	0.17	0.18

Please contact us for different motor adapters and input shaft bore.

TR 060

IS

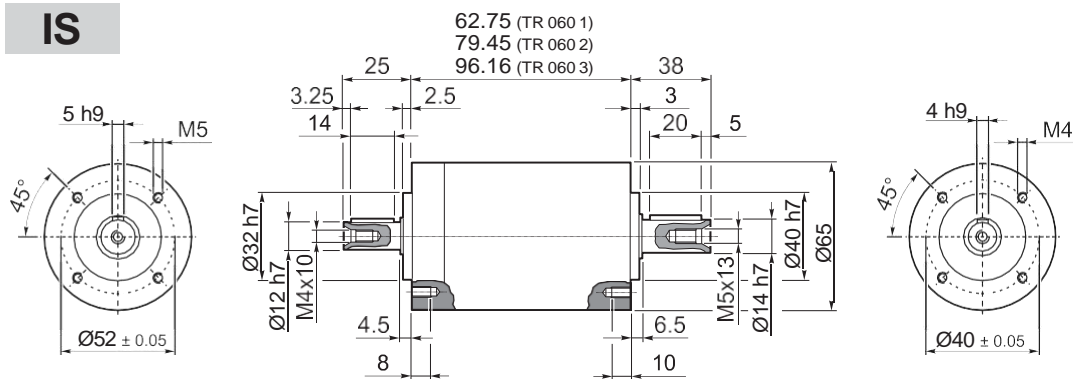

TR 060 1	1.2
TR 060 2	1.7
TR 060 3	2.0

TR

25AH ... 80A

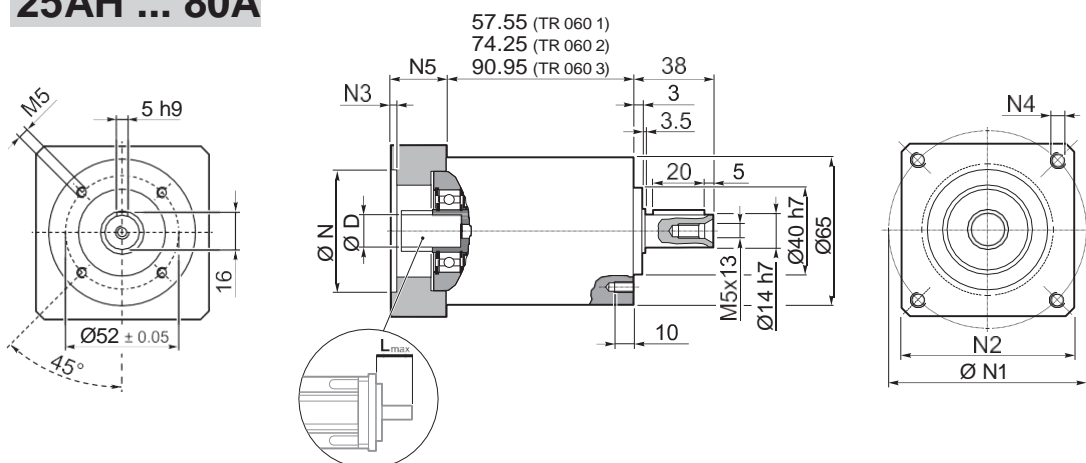

TR 060 1	1.2
TR 060 2	1.7
TR 060 3	2.0

												N	N1		N2	N3	N4	N5	L _{max}
	6	6.35	7	8	9	9.52	-	-	-	-	-		min	max					
25AH	6	6.35	7	8	9	9.52	-	-	-	-	-	25	39	56					
26AH	6	6.35	7	8	9	9.52	-	-	-	-	-	26	39	56					
28AH	6	6.35	7	8	9	9.52	-	-	-	-	-	28	39	56					
30AH	6	6.35	7	8	9	9.52	-	-	-	-	-	30	39	56					
32AH	6	6.35	7	8	9	9.52	-	-	-	-	-	32	39	56	65	3.5	4.5	25	25
34AH	6	6.35	7	8	9	9.52	-	-	-	-	-	34	40	56					
36AH	6	6.35	7	8	9	9.52	-	-	-	-	-	36	42	56					
39AH	6	6.35	7	8	9	9.52	-	-	-	-	-	39	45	56					
40AH	6	6.35	7	8	9	9.52	-	-	-	-	-	40	46	56					
38B	6	6.35	7	8	9	9.52	10	11	12	12.7	-	38.1	66.6		60	3	M4x10	18	25
40B	6	6.35	7	8	9	9.52	10	11	12	12.7	-	40	63		60	3	M4x10	18	25
50A	6	6.35	7	8	9	9.52	10	11	12	12.7	-	50	60		60	3	M4x10	18	25
50B	6	6.35	7	8	9	9.52	10	11	12	12.7	14	50	65		60	3	M5x12	23	30
50BH	6	6.35	7	8	9	9.52	10	11	12	12.7	14	50	65		65	3	5.5	25	32
50C	6	6.35	7	8	9	9.52	10	11	12	12.7	14	50	70		60	3	M4x10	23	30
55MH	6	6.35	7	8	9	9.52	10	11	12	12.7	-	55	80		65	2	5.5	16	23
60A	6	6.35	7	8	9	9.52	10	11	12	12.7	-	60	75		65	3	M5x12	18	25
60AH	6	6.35	7	8	9	9.52	10	11	12	12.7	-	60	75		65	3	5.5	18	25
60A1	6	6.35	7	8	9	9.52	10	11	12	12.7	14	60	75		65	3	M5x12	23	30
60AH1	6	6.35	7	8	9	9.52	10	11	12	12.7	14	60	75		65	3	5.5	23	30
60B	6	6.35	7	8	9	9.52	10	11	12	12.7	14	60	85		75	3	M5x12	23	30
60C	6	6.35	7	8	9	9.52	10	11	12	12.7	14	60	90		75	3	M5x12	23	30
70A	6	6.35	7	8	9	9.52	10	11	12	12.7	14	70	85		75	3	M6x15	23	30
70B	6	6.35	7	8	9	9.52	10	11	12	12.7	14	70	90		75	5	M5x12	23	30
73A	6	6.35	7	8	9	9.52	10	11	12	12.7	14	73	98.4		85	3	M5x12	25	32
80A	6	6.35	7	8	9	9.52	10	11	12	12.7	14	80	100		85	3	M6x15	23	30

TR 060

FM

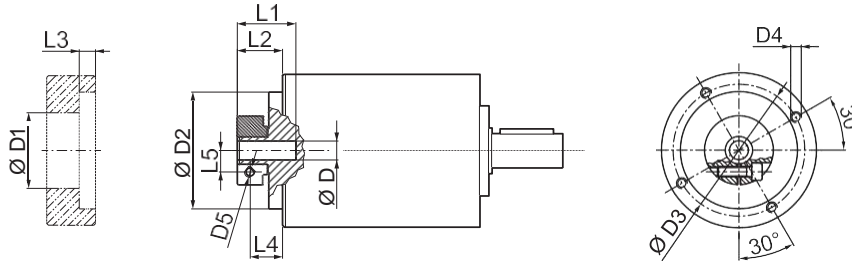

D				D1	D2	D3	D4	D5	L1	L2	L3	L4	L5
6	6.35	7		32.5	50	42.5	M4x8	M4	20.2	13.2	3	8.7	8
8	9	9.52	10	32.5	50	42.5	M4x8	M4	20.2	13.2	3	7.8	9
11	12	12.7		35.5	50	42.5	M4x8	M4	20.5	13.5	3	8.5	11
14				35.5	50	42.5	M4x8	M4	24	17	3	10.2	11.5

 i	M _{n 2}	M _{a 2}	M _{p 2}	n ₁	n _{1 max}	φ _S	φ _R	C _t	R _{1 max}	R _{2 max}	A _{2 max}	η	J _G [kgcm ²]	
	[Nm]	[Nm]	[Nm]	[min ⁻¹]	[min ⁻¹]	[arcmin]		$\frac{Nm}{arcmin}$	[N]	[N]	[N]	%	6 ... 9.52	10 ... 14
TR 060 1_3	18	35	70	3300	4000	5'	3'	3.0	200	600	700	97	0.10	0.11
TR 060 1_4	25	40	90	3500	5000	5'	3'	3.0	200	600	700	97	0.06	0.08
TR 060 1_5	25	40	90	3500	5000	5'	3'	3.0	200	600	700	97	0.05	0.07
TR 060 1_6	25	40	90	3500	5000	5'	3'	3.0	200	600	700	97	0.04	0.06
TR 060 1_7	25	40	90	4000	6000	5'	3'	3.0	200	600	700	97	0.04	0.06
TR 060 1_10	18	35	70	4000	6000	5'	3'	3.0	200	600	700	97	0.03	0.05
TR 060 2_9	18	35	70	3300	4000	5'	3'	2.5	200	600	700	94	0.10	0.12
TR 060 2_12	30	45	100	3300	4000	5'	3'	2.5	200	600	700	94	0.10	0.11
TR 060 2_15	30	45	100	3300	4000	5'	3'	2.5	200	600	700	94	0.09	0.11
TR 060 2_16	30	45	100	3500	5000	5'	3'	2.5	200	600	700	94	0.06	0.08
TR 060 2_20	30	45	100	3500	5000	5'	3'	2.5	200	600	700	94	0.05	0.07
TR 060 2_25	30	45	100	3500	5000	5'	3'	2.5	200	600	700	94	0.05	0.06
TR 060 2_28	30	45	100	4000	6000	5'	3'	2.5	200	600	700	94	0.04	0.06
TR 060 2_30	18	35	70	4000	6000	5'	3'	2.5	200	600	700	94	0.03	0.05
TR 060 2_35	30	45	100	4000	6000	5'	3'	2.5	200	600	700	94	0.04	0.06
TR 060 2_36	25	40	90	3500	5000	5'	3'	2.5	200	600	700	94	0.04	0.06
TR 060 2_40	30	45	100	4000	6000	5'	3'	2.5	200	600	700	94	0.03	0.05
TR 060 2_50	30	45	100	4000	6000	5'	3'	2.5	200	600	700	94	0.03	0.05
TR 060 2_70	30	45	100	4000	6000	5'	3'	2.5	200	600	700	94	0.03	0.05
TR 060 2_100	18	35	70	4000	6000	5'	3'	2.5	200	600	700	94	0.03	0.05
TR 060 3_48	30	45	100	3500	5000	7'	5'	2.0	200	600	700	91	0.06	0.08
TR 060 3_64	30	45	100	3500	5000	7'	5'	2.0	200	600	700	91	0.06	0.08
TR 060 3_75	30	45	100	3500	5000	7'	5'	2.0	200	600	700	91	0.05	0.07
TR 060 3_80	30	45	100	3500	5000	7'	5'	2.0	200	600	700	91	0.06	0.08
TR 060 3_84	30	45	100	4000	6000	7'	5'	2.0	200	600	700	91	0.04	0.06
TR 060 3_90	18	35	70	4000	6000	7'	5'	2.0	200	600	700	91	0.03	0.05
TR 060 3_120	30	45	100	4000	6000	7'	5'	2.0	200	600	700	91	0.03	0.05
TR 060 3_125	30	45	100	3500	5000	7'	5'	2.0	200	600	700	91	0.05	0.07
TR 060 3_140	30	45	100	4000	6000	7'	5'	2.0	200	600	700	91	0.04	0.06
TR 060 3_150	30	45	100	4000	6000	7'	5'	2.0	200	600	700	91	0.03	0.05
TR 060 3_160	30	45	100	4000	6000	7'	5'	2.0	200	600	700	91	0.03	0.05
TR 060 3_175	30	45	100	4000	6000	7'	5'	2.0	200	600	700	91	0.04	0.06
TR 060 3_200	30	45	100	4000	6000	7'	5'	2.0	200	600	700	91	0.03	0.05
TR 060 3_210	30	45	100	4000	6000	7'	5'	2.0	200	600	700	91	0.03	0.05
TR 060 3_216	30	45	100	3500	5000	7'	5'	2.0	200	600	700	91	0.04	0.06
TR 060 3_250	30	45	100	4000	6000	7'	5'	2.0	200	600	700	91	0.03	0.05
TR 060 3_280	30	45	100	4000	6000	7'	5'	2.0	200	600	700	91	0.03	0.05
TR 060 3_350	30	45	100	4000	6000	7'	5'	2.0	200	600	700	91	0.03	0.05
TR 060 3_400	30	45	100	4000	6000	7'	5'	2.0	200	600	700	91	0.03	0.05
TR 060 3_500	30	45	100	4000	6000	7'	5'	2.0	200	600	700	91	0.03	0.05
TR 060 3_700	30	45	100	4000	6000	7'	5'	2.0	200	600	700	91	0.03	0.05
TR 060 3_1000	18	35	70	4000	6000	7'	5'	2.0	200	600	700	91	0.03	0.05

TR

Please contact us for different motor adapters and input shaft bore.

TR K 060

25AH ... 80A

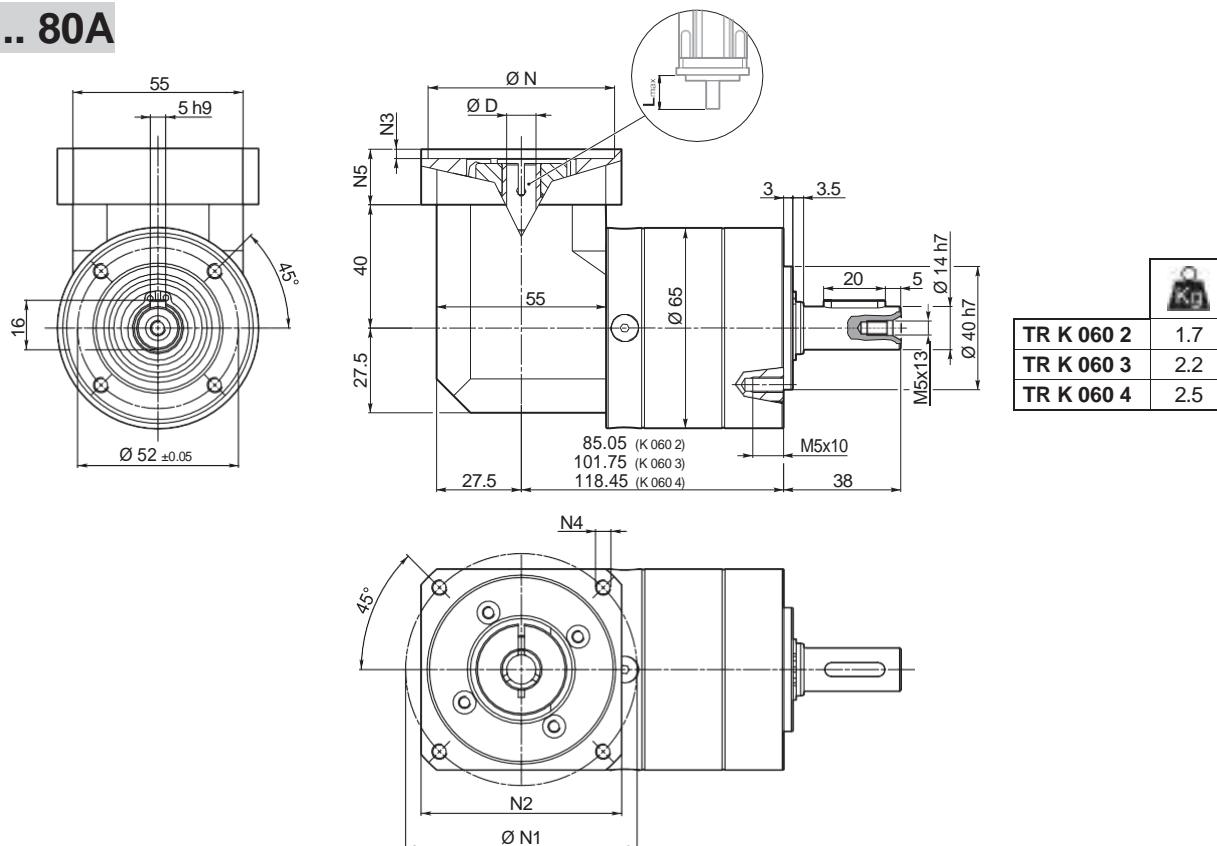

TR

	D											N	N1		N2	N3	N4	N5	L _{max}
	6	6.35	7	8	9	9.52	-	-	-	-	-		min	max					
25AH	6	6.35	7	8	9	9.52	-	-	-	-	-	25	39	56					
26AH	6	6.35	7	8	9	9.52	-	-	-	-	-	26	39	56					
28AH	6	6.35	7	8	9	9.52	-	-	-	-	-	28	39	56					
30AH	6	6.35	7	8	9	9.52	-	-	-	-	-	30	39	56					
32AH	6	6.35	7	8	9	9.52	-	-	-	-	-	32	39	56	65	3.5	4.5	25	25
34AH	6	6.35	7	8	9	9.52	-	-	-	-	-	34	40	56					
36AH	6	6.35	7	8	9	9.52	-	-	-	-	-	36	42	56					
39AH	6	6.35	7	8	9	9.52	-	-	-	-	-	39	45	56					
40AH	6	6.35	7	8	9	9.52	-	-	-	-	-	40	46	56					
38B	6	6.35	7	8	9	9.52	10	11	12	12.7	-	38.1	66.6	60	3	M4x10	18	25	
40B	6	6.35	7	8	9	9.52	10	11	12	12.7	-	40	63	60	3	M4x10	18	25	
50A	6	6.35	7	8	9	9.52	10	11	12	12.7	-	50	60	60	3	M4x10	18	25	
50B	6	6.35	7	8	9	9.52	10	11	12	12.7	14	50	65	60	3	M5x12	23	30	
50BH	6	6.35	7	8	9	9.52	10	11	12	12.7	14	50	65	65	3	5.5	25	32	
50C	6	6.35	7	8	9	9.52	10	11	12	12.7	14	50	70	60	3	M4x10	23	30	
55MH	6	6.35	7	8	9	9.52	10	11	12	12.7	-	55	80	65	2	5.5	16	23	
60A	6	6.35	7	8	9	9.52	10	11	12	12.7	-	60	75	65	3	M5x12	18	25	
60A1	6	6.35	7	8	9	9.52	10	11	12	12.7	14	60	75	65	3	M5x12	23	30	
60B	6	6.35	7	8	9	9.52	10	11	12	12.7	14	60	85	75	3	M5x12	23	30	
60C	6	6.35	7	8	9	9.52	10	11	12	12.7	14	60	90	75	3	M5x12	23	30	
70A	6	6.35	7	8	9	9.52	10	11	12	12.7	14	70	85	75	3	M6x15	23	30	
70B	6	6.35	7	8	9	9.52	10	11	12	12.7	14	70	90	75	5	M5x12	23	30	
73A	6	6.35	7	8	9	9.52	10	11	12	12.7	14	73	98.4	85	3	M5x12	25	32	
80A	6	6.35	7	8	9	9.52	10	11	12	12.7	14	80	100	85	3	M6x15	23	30	

TR K 060

FM

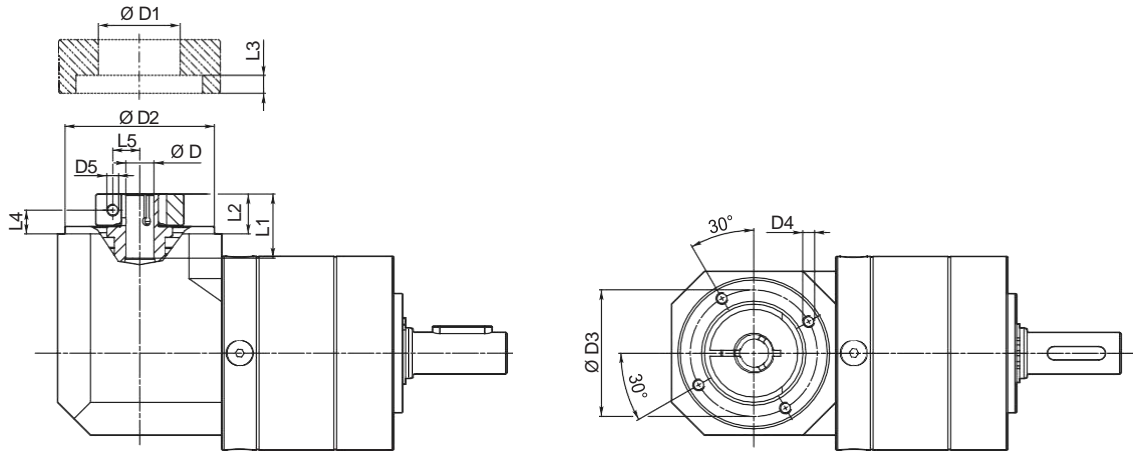

D				D1	D2	D3	D4	D5	L1	L2	L3	L4	L5
6	6.35	7		32.5	50	42.5	M4x8	M4	20.2	13.2	3	8.7	8
8	9	9.52	10	32.5	50	42.5	M4x8	M4	20.2	13.2	3	7.8	9
11	12	12.7		35.5	50	42.5	M4x8	M4	20.5	13.5	3	8.5	11
14				35.5	50	42.5	M4x8	M4	24	17	3	10.2	11.5

TR

i	M _{n 2} [Nm]	M _{a 2} [Nm]	M _{p 2} [Nm]	n ₁ [min ⁻¹]	n _{1 max} [min ⁻¹]	φ _S [arcmin]	φ _R [arcmin]	C _t $\frac{Nm}{arcmin}$	R _{2 max} [N]	A _{2 max} [N]	η %	J _G [kgcm ²]	
												D	D
TR K 060 2_3	18	35	70	3300	4000	5'	3'	3.0	600	700	94	0.20	0.20
TR K 060 2_4	25	40	90	3500	5000	5'	3'	3.0	600	700	94	0.18	0.20
TR K 060 2_5	25	40	90	3500	5000	5'	3'	3.0	600	700	94	0.17	0.19
TR K 060 2_6	25	40	90	3500	5000	5'	3'	3.0	600	700	94	0.17	0.19
TR K 060 2_7	25	40	90	4000	6000	5'	3'	3.0	600	700	94	0.17	0.19
TR K 060 2_10	18	35	70	4000	6000	5'	3'	3.0	600	700	94	0.17	0.18
TR K 060 3_9	18	35	70	3300	4000	5'	3'	2.5	600	700	91	0.20	0.21
TR K 060 3_12	30	45	100	3300	4000	5'	3'	2.5	600	700	91	0.20	0.21
TR K 060 3_15	30	45	100	3300	4000	5'	3'	2.5	600	700	91	0.19	0.21
TR K 060 3_16	30	45	100	3500	5000	5'	3'	2.5	600	700	91	0.18	0.20
TR K 060 3_20	30	45	100	3500	5000	5'	3'	2.5	600	700	91	0.17	0.19
TR K 060 3_25	30	45	100	3500	5000	5'	3'	2.5	600	700	91	0.17	0.18
TR K 060 3_28	30	45	100	4000	6000	5'	3'	2.5	600	700	91	0.17	0.19
TR K 060 3_30	18	35	70	4000	6000	5'	3'	2.5	600	700	91	0.17	0.18
TR K 060 3_35	30	45	100	4000	6000	5'	3'	2.5	600	700	91	0.18	0.19
TR K 060 3_36	25	40	90	3500	5000	5'	3'	2.5	600	700	91	0.18	0.19
TR K 060 3_40	30	45	100	4000	6000	5'	3'	2.5	600	700	91	0.17	0.18
TR K 060 3_50	30	45	100	4000	6000	5'	3'	2.5	600	700	91	0.17	0.18
TR K 060 3_70	30	45	100	4000	6000	5'	3'	2.5	600	700	91	0.17	0.18
TR K 060 3_100	18	35	70	4000	6000	5'	3'	2.5	600	700	91	0.17	0.18
TR K 060 4_48	30	45	100	3500	5000	7'	5'	2.0	600	700	89	0.18	0.20
TR K 060 4_64	30	45	100	3500	5000	7'	5'	2.0	600	700	89	0.18	0.20
TR K 060 4_75	30	45	100	3500	5000	7'	5'	2.0	600	700	89	0.17	0.19
TR K 060 4_80	30	45	100	3500	5000	7'	5'	2.0	600	700	89	0.18	0.20
TR K 060 4_84	30	45	100	4000	6000	7'	5'	2.0	600	700	89	0.17	0.19
TR K 060 4_90	18	35	70	4000	6000	7'	5'	2.0	600	700	89	0.17	0.18
TR K 060 4_120	30	45	100	4000	6000	7'	5'	2.0	600	700	89	0.15	0.17
TR K 060 4_125	30	45	100	3500	5000	7'	5'	2.0	600	700	89	0.17	0.19
TR K 060 4_140	30	45	100	4000	6000	7'	5'	2.0	600	700	89	0.17	0.19
TR K 060 4_150	30	45	100	4000	6000	7'	5'	2.0	600	700	89	0.17	0.18
TR K 060 4_160	30	45	100	4000	6000	7'	5'	2.0	600	700	89	0.17	0.18
TR K 060 4_175	30	45	100	4000	6000	7'	5'	2.0	600	700	89	0.17	0.19
TR K 060 4_200	30	45	100	4000	6000	7'	5'	2.0	600	700	89	0.17	0.18
TR K 060 4_210	30	45	100	4000	6000	7'	5'	2.0	600	700	89	0.17	0.18
TR K 060 4_216	30	45	100	3500	5000	7'	5'	2.0	600	700	89	0.17	0.19
TR K 060 4_250	30	45	100	4000	6000	7'	5'	2.0	600	700	89	0.17	0.18
TR K 060 4_280	30	45	100	4000	6000	7'	5'	2.0	600	700	89	0.17	0.18
TR K 060 4_350	30	45	100	4000	6000	7'	5'	2.0	600	700	89	0.17	0.18
TR K 060 4_400	30	45	100	4000	6000	7'	5'	2.0	600	700	89	0.17	0.18
TR K 060 4_500	30	45	100	4000	6000	7'	5'	2.0	600	700	89	0.17	0.18
TR K 060 4_700	30	45	100	4000	6000	7'	5'	2.0	600	700	89	0.17	0.18
TR K 060 4_1000	18	35	70	4000	6000	7'	5'	2.0	600	700	89	0.17	0.18

Please contact us for different motor adapters and input shaft bore.

TR 080

IS

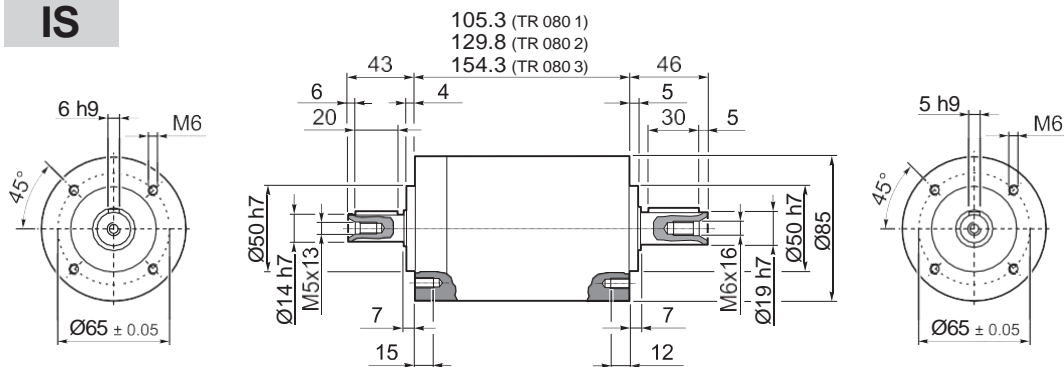

TR 080 1	4.0
TR 080 2	4.6
TR 080 3	5.2

TR

40B1 ... 110B1

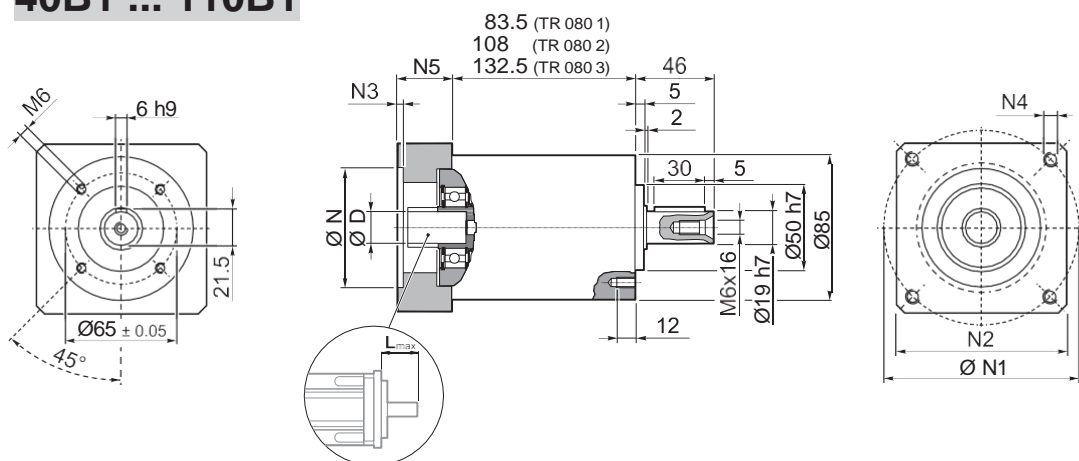

TR 080 1	4.0
TR 080 2	4.6
TR 080 3	5.2

											N	N1	N2	N3	N4	N5	L _{max}		
40B1	8	9	9.52	11	12	12.7	14	-	-	-	-	40	63	80	4	M4x12	34	40	
45A	8	9	9.52	11	12	12.7	-	-	-	-	-	45	63	80	4	M4x12	34	40	
50B1	8	9	9.52	11	12	12.7	14	-	-	-	-	50	65	80	4	M5x16	34	40	
50BH1	8	9	9.52	11	12	12.7	14	-	-	-	-	50	65	80	4	5.5	34	40	
50C1	8	9	9.52	11	12	12.7	14	-	-	-	-	50	70	80	4	M4x10	34	40	
50D	8	9	9.52	11	12	12.7	14	-	-	-	-	50	95	80	4	M6x20	34	40	
55A	8	9	9.52	11	12	12.7	14	15.875	16	17	19	19.05	55.5	125.7	105	4	M6x20	34	40
60A2	8	9	9.52	11	12	12.7	14	-	-	-	-	60	75	80	4	M5x16	34	40	
60AH2	8	9	9.52	11	12	12.7	14	-	-	-	-	60	75	90	4	6.5	34	40	
60B1	8	9	9.52	11	12	12.7	14	15.875	16	-	-	60	85	80	4	M5x16	34	40	
60C1	8	9	9.52	11	12	12.7	14	15.875	16	-	-	60	90	80	4	M5x16	34	40	
70A1	8	9	9.52	11	12	12.7	14	15.875	16	17	19	19.05	70	85	80	4	M6x20	34	40
70AH1	8	9	9.52	11	12	12.7	14	15.875	16	17	19	19.05	70	85	90	4	6.5	34	40
70B1	8	9	9.52	11	12	12.7	14	15.875	16	17	19	19.05	70	90	80	4	M5x16	34	40
73A1	8	9	9.52	11	12	12.7	14	-	-	-	-	73	98.4	85	4	M5x16	34	40	
80A1	8	9	9.52	11	12	12.7	14	15.875	16	17	19	19.05	80	100	90	4	M6x16	34	40
95A	8	9	9.52	11	12	12.7	14	15.875	16	17	19	19.05	95	115	100	4	M8x20	34	40
95B	8	9	9.52	11	12	12.7	14	15.875	16	17	19	19.05	95	130	115	4	M8x20	34	40
110A	8	9	9.52	11	12	12.7	14	15.875	16	17	19	19.05	110	130	115	4	M8x20	34	40
110B	8	9	9.52	11	12	12.7	14	15.875	16	17	19	19.05	110	145	120	6.5	M8x20	44	50
110B1	8	9	9.52	11	12	12.7	14	15.875	16	17	19	19.05	110	145	120	6.5	M8x20	54	60

TR 080

FM

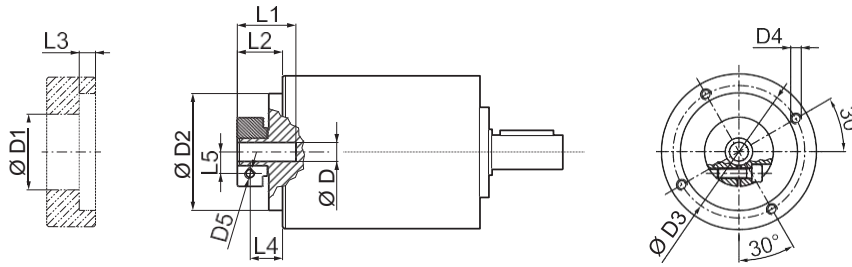

D				D1	D2	D3	D4	D5	L1	L2	L3	L4	L5
8	9	9.52		38	68	76.5	M6x12	M6	32.2	26.3	9.5	19.3	10.5
11	12	12.7		43	68	76.5	M6x12	M6	32.2	26.3	9.5	19.3	12.5
14	15.875	16	17	48	68	76.5	M6x12	M6	32.2	26.3	9.5	19.3	14.5
19	19.05			51	68	76.5	M6x12	M6	32.2	26.3	9.5	19.3	16.5

 i	M_{n2}	M_{a2}	M_{p2}	n_1	n_{1max}	ϕ_S	ϕ_R	C_t	R_{1max}	R_{2max}	A_{2max}	η	J_G [kgcm ²]	
	[Nm]	[Nm]	[Nm]	[min ⁻¹]	[min ⁻¹]	[arcmin]	[arcmin]	$\frac{Nm}{arcmin}$	[N]	[N]	[N]	%	8 ... 12.7	14 ... 19.05
TR 080 1_3	40	80	180	2900	3500	5'	3'	8.0	400	2500	3000	97	0.50	0.59
TR 080 1_4	50	80	200	3100	4500	5'	3'	8.0	400	2500	3000	97	0.34	0.43
TR 080 1_5	50	80	200	3200	4500	5'	3'	8.0	400	2500	3000	97	0.28	0.37
TR 080 1_6	50	80	200	3200	4500	5'	3'	8.0	400	2500	3000	97	0.21	0.30
TR 080 1_7	50	80	200	4000	6000	5'	3'	8.0	400	2500	3000	97	0.23	0.32
TR 080 1_10	40	80	180	4000	6000	5'	3'	8.0	400	2500	3000	97	0.20	0.29
TR 080 2_9	40	80	180	2900	3500	5'	3'	6.5	400	2500	3000	94	0.49	0.58
TR 080 2_12	70	100	250	2900	3500	5'	3'	6.5	400	2500	3000	94	0.47	0.56
TR 080 2_15	70	100	250	2900	3500	5'	3'	6.5	400	2500	3000	94	0.46	0.55
TR 080 2_16	70	100	250	3100	4500	5'	3'	6.5	400	2500	3000	94	0.32	0.41
TR 080 2_20	70	100	250	3200	4500	5'	3'	6.5	400	2500	3000	94	0.27	0.36
TR 080 2_25	70	100	250	3200	4500	5'	3'	6.5	400	2500	3000	94	0.27	0.36
TR 080 2_28	70	100	250	4000	6000	5'	3'	6.5	400	2500	3000	94	0.22	0.31
TR 080 2_30	40	80	180	4000	6000	5'	3'	6.5	400	2500	3000	94	0.20	0.29
TR 080 2_35	70	100	250	4000	6000	5'	3'	6.5	400	2500	3000	94	0.22	0.31
TR 080 2_36	50	80	200	3200	4500	5'	3'	6.5	400	2500	3000	94	0.20	0.29
TR 080 2_40	70	100	250	4000	6000	5'	3'	6.5	400	2500	3000	94	0.20	0.29
TR 080 2_50	70	100	250	4000	6000	5'	3'	6.5	400	2500	3000	94	0.19	0.28
TR 080 2_70	70	100	250	4000	6000	5'	3'	6.5	400	2500	3000	94	0.19	0.28
TR 080 2_100	40	80	180	4000	6000	5'	3'	6.5	400	2500	3000	94	0.19	0.28
TR 080 3_48	70	100	250	3100	4500	7'	5'	5.5	400	2500	3000	91	0.33	0.42
TR 080 3_64	70	100	250	3100	4500	7'	5'	5.5	400	2500	3000	91	0.32	0.41
TR 080 3_75	70	100	250	3200	4500	7'	5'	5.5	400	2500	3000	91	0.27	0.36
TR 080 3_80	70	100	250	3100	4500	7'	5'	5.5	400	2500	3000	91	0.32	0.41
TR 080 3_84	70	100	250	4000	6000	7'	5'	5.5	400	2500	3000	91	0.23	0.32
TR 080 3_90	40	80	180	4000	6000	7'	5'	5.5	400	2500	3000	91	0.20	0.29
TR 080 3_120	70	100	250	4000	6000	7'	5'	5.5	400	2500	3000	91	0.20	0.29
TR 080 3_125	70	100	250	3200	4500	7'	5'	5.5	400	2500	3000	91	0.27	0.36
TR 080 3_140	70	100	250	4000	6000	7'	5'	5.5	400	2500	3000	91	0.22	0.31
TR 080 3_150	70	100	250	4000	6000	7'	5'	5.5	400	2500	3000	91	0.20	0.29
TR 080 3_160	70	100	250	4000	6000	7'	5'	5.5	400	2500	3000	91	0.20	0.29
TR 080 3_175	70	100	250	4000	6000	7'	5'	5.5	400	2500	3000	91	0.22	0.31
TR 080 3_200	70	100	250	4000	6000	7'	5'	5.5	400	2500	3000	91	0.20	0.29
TR 080 3_210	70	100	250	4000	6000	7'	5'	5.5	400	2500	3000	91	0.20	0.29
TR 080 3_216	70	100	250	3200	4500	7'	5'	5.5	400	2500	3000	91	0.20	0.29
TR 080 3_250	70	100	250	4000	6000	7'	5'	5.5	400	2500	3000	91	0.19	0.28
TR 080 3_280	70	100	250	4000	6000	7'	5'	5.5	400	2500	3000	91	0.19	0.28
TR 080 3_350	70	100	250	4000	6000	7'	5'	5.5	400	2500	3000	91	0.19	0.28
TR 080 3_400	70	100	250	4000	6000	7'	5'	5.5	400	2500	3000	91	0.19	0.28
TR 080 3_500	70	100	250	4000	6000	7'	5'	5.5	400	2500	3000	91	0.19	0.28
TR 080 3_700	70	100	250	4000	6000	7'	5'	5.5	400	2500	3000	91	0.19	0.28
TR 080 3_1000	40	80	180	4000	6000	7'	5'	5.5	400	2500	3000	91	0.19	0.28

Please contact us for different motor adapters and input shaft bore.

TR G 080

40B1 ... 110B1

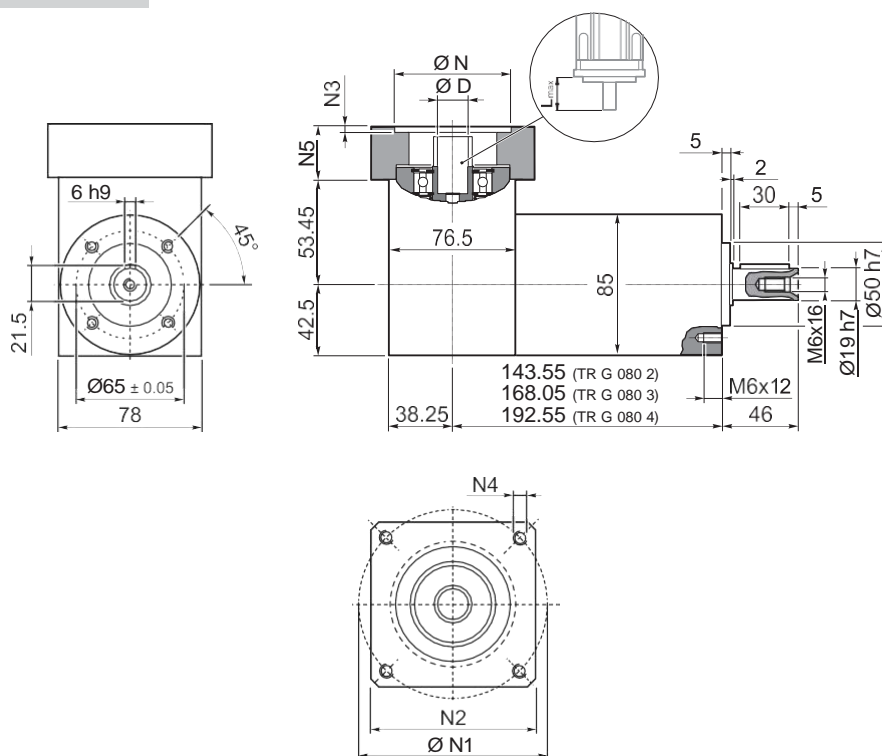

	TR G 080 2	5.2
	TR G 080 3	5.8
	TR G 080 4	6.4

TR

											N	N1	N2	N3	N4	N5	L _{max}		
40B1	8	9	9.52	11	12	12.7	14	-	-	-	-	40	63	80	4	M4x12	34	40	
45A	8	9	9.52	11	12	12.7	-	-	-	-	-	45	63	80	4	M4x12	34	40	
50B1	8	9	9.52	11	12	12.7	14	-	-	-	-	50	65	80	4	M5x16	34	40	
50BH1	8	9	9.52	11	12	12.7	14	-	-	-	-	50	65	80	4	5.5	34	40	
50C1	8	9	9.52	11	12	12.7	14	-	-	-	-	50	70	80	4	M4x10	34	40	
50D	8	9	9.52	11	12	12.7	14	-	-	-	-	50	95	80	4	M6x20	34	40	
55A	8	9	9.52	11	12	12.7	14	15.875	16	17	19	19.05	55.5	125.7	105	4	M6x20	34	40
60A2	8	9	9.52	11	12	12.7	14	-	-	-	-	60	75	80	4	M5x16	34	40	
60AH2	8	9	9.52	11	12	12.7	14	-	-	-	-	60	75	90	4	6.5	34	40	
60B1	8	9	9.52	11	12	12.7	14	15.875	16	-	-	60	85	80	4	M5x16	34	40	
60C1	8	9	9.52	11	12	12.7	14	15.875	16	-	-	60	90	80	4	M5x16	34	40	
70A1	8	9	9.52	11	12	12.7	14	15.875	16	17	19	19.05	70	85	80	4	M6x20	34	40
70AH1	8	9	9.52	11	12	12.7	14	15.875	16	17	19	19.05	70	85	90	4	6.5	34	40
70B1	8	9	9.52	11	12	12.7	14	15.875	16	17	19	19.05	70	90	80	4	M5x16	34	40
73A1	8	9	9.52	11	12	12.7	14	-	-	-	-	73	98.4	85	4	M5x16	34	40	
80A1	8	9	9.52	11	12	12.7	14	15.875	16	17	19	19.05	80	100	90	4	M6x16	34	40
95A	8	9	9.52	11	12	12.7	14	15.875	16	17	19	19.05	95	115	100	4	M8x20	34	40
95B	8	9	9.52	11	12	12.7	14	15.875	16	17	19	19.05	95	130	115	4	M8x20	34	40
110A	8	9	9.52	11	12	12.7	14	15.875	16	17	19	19.05	110	130	115	4	M8x20	34	40
110B	8	9	9.52	11	12	12.7	14	15.875	16	17	19	19.05	110	145	120	6.5	M8x20	44	50
110B1	8	9	9.52	11	12	12.7	14	15.875	16	17	19	19.05	110	145	120	6.5	M8x20	54	60

TR G 080

FM

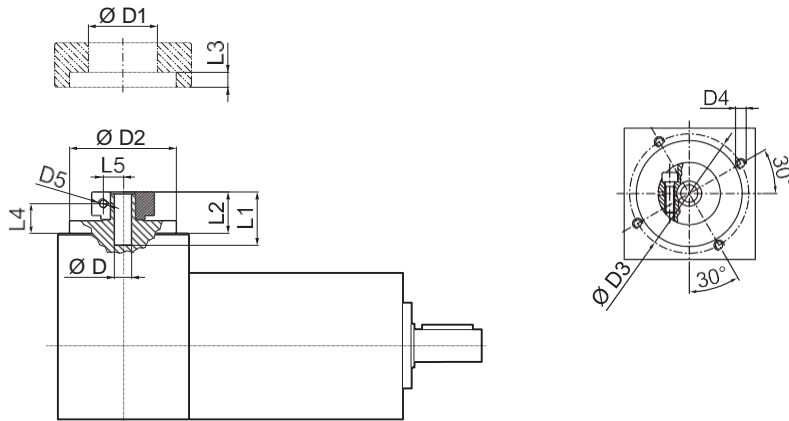

D				D1	D2	D3	D4	D5	L1	L2	L3	L4	L5
8	9	9.52		38	68	76.5	M6x12	M6	32.2	26.3	9.5	19.3	10.5
11	12	12.7		43	68	76.5	M6x12	M6	32.2	26.3	9.5	19.3	12.5
14	15.875	16	17	48	68	76.5	M6x12	M6	32.2	26.3	9.5	19.3	14.5
19	19.05			51	68	76.5	M6x12	M6	32.2	26.3	9.5	19.3	16.5

TR

 i	M _{n 2}	M _{a 2}	M _{p 2}	n ₁	n _{1 max}	φ _S	φ _R	C _t	R _{2 max}	A _{2 max}	η	J _G [kgcm ²]	
	[Nm]	[Nm]	[Nm]	[min ⁻¹]	[min ⁻¹]	[arcmin]	[arcmin]	$\frac{Nm}{arcmin}$	[N]	[N]	%	8 ... 12.7	14 ... 19.05
TR G 080 2_3	40	80	180	2900	3500	5'	3'	8.0	2500	3000	94	0.67	0.79
TR G 080 2_4	50	80	200	3100	4500	5'	3'	8.0	2500	3000	94	0.62	0.75
TR G 080 2_5	50	80	200	3200	4500	5'	3'	8.0	2500	3000	94	0.61	0.74
TR G 080 2_6	50	80	200	3200	4500	5'	3'	8.0	2500	3000	94	0.58	0.71
TR G 080 2_7	50	80	200	4000	6000	5'	3'	8.0	2500	3000	94	0.60	0.73
TR G 080 2_10	40	80	180	4000	6000	5'	3'	8.0	2500	3000	94	0.60	0.72
TR G 080 3_9	40	80	180	2900	3500	5'	3'	6.5	2500	3000	91	0.66	0.78
TR G 080 3_12	70	100	250	2900	3500	5'	3'	6.5	2500	3000	91	0.75	0.87
TR G 080 3_15	70	100	250	2900	3500	5'	3'	6.5	2500	3000	91	0.74	0.87
TR G 080 3_16	70	100	250	3100	4500	5'	3'	6.5	2500	3000	91	0.60	0.73
TR G 080 3_20	70	100	250	3200	4500	5'	3'	6.5	2500	3000	91	0.60	0.73
TR G 080 3_25	70	100	250	3200	4500	5'	3'	6.5	2500	3000	91	0.64	0.76
TR G 080 3_28	70	100	250	4000	6000	5'	3'	6.5	2500	3000	91	0.59	0.72
TR G 080 3_30	40	80	180	4000	6000	5'	3'	6.5	2500	3000	91	0.60	0.72
TR G 080 3_35	70	100	250	4000	6000	5'	3'	6.5	2500	3000	91	0.61	0.74
TR G 080 3_36	50	80	200	3200	4500	5'	3'	6.5	2500	3000	91	0.57	0.70
TR G 080 3_40	70	100	250	4000	6000	5'	3'	6.5	2500	3000	91	0.60	0.72
TR G 080 3_50	70	100	250	4000	6000	5'	3'	6.5	2500	3000	91	0.59	0.71
TR G 080 3_70	70	100	250	4000	6000	5'	3'	6.5	2500	3000	91	0.59	0.71
TR G 080 3_100	40	80	180	4000	6000	5'	3'	6.5	2500	3000	91	0.59	0.71
TR G 080 4_48	70	100	250	3100	4500	7'	5'	5.5	2500	3000	89	0.61	0.75
TR G 080 4_64	70	100	250	3100	4500	7'	5'	5.5	2500	3000	89	0.60	0.73
TR G 080 4_75	70	100	250	3200	4500	7'	5'	5.5	2500	3000	89	0.60	0.73
TR G 080 4_80	70	100	250	3100	4500	7'	5'	5.5	2500	3000	89	0.60	0.73
TR G 080 4_84	70	100	250	4000	6000	7'	5'	5.5	2500	3000	89	0.60	0.73
TR G 080 4_90	40	80	180	4000	6000	7'	5'	5.5	2500	3000	89	0.60	0.72
TR G 080 4_120	70	100	250	4000	6000	7'	5'	5.5	2500	3000	89	0.60	0.72
TR G 080 4_125	70	100	250	3200	4500	7'	5'	5.5	2500	3000	89	0.60	0.73
TR G 080 4_140	70	100	250	4000	6000	7'	5'	5.5	2500	3000	89	0.59	0.72
TR G 080 4_150	70	100	250	4000	6000	7'	5'	5.5	2500	3000	89	0.60	0.72
TR G 080 4_160	70	100	250	4000	6000	7'	5'	5.5	2500	3000	89	0.60	0.72
TR G 080 4_175	70	100	250	4000	6000	7'	5'	5.5	2500	3000	89	0.59	0.72
TR G 080 4_200	70	100	250	4000	6000	7'	5'	5.5	2500	3000	89	0.60	0.72
TR G 080 4_210	70	100	250	4000	6000	7'	5'	5.5	2500	3000	89	0.60	0.72
TR G 080 4_216	70	100	250	3200	4500	7'	5'	5.5	2500	3000	89	0.57	0.70
TR G 080 4_250	70	100	250	4000	6000	7'	5'	5.5	2500	3000	89	0.59	0.71
TR G 080 4_280	70	100	250	4000	6000	7'	5'	5.5	2500	3000	89	0.59	0.71
TR G 080 4_350	70	100	250	4000	6000	7'	5'	5.5	2500	3000	89	0.59	0.71
TR G 080 4_400	70	100	250	4000	6000	7'	5'	5.5	2500	3000	89	0.59	0.71
TR G 080 4_500	70	100	250	4000	6000	7'	5'	5.5	2500	3000	89	0.59	0.71
TR G 080 4_700	70	100	250	4000	6000	7'	5'	5.5	2500	3000	89	0.59	0.71
TR G 080 4_1000	40	80	180	4000	6000	7'	5'	5.5	2500	3000	89	0.59	0.71

Please contact us for different motor adapters and input shaft bore.

TR MB 080

40B1 ... 110B1

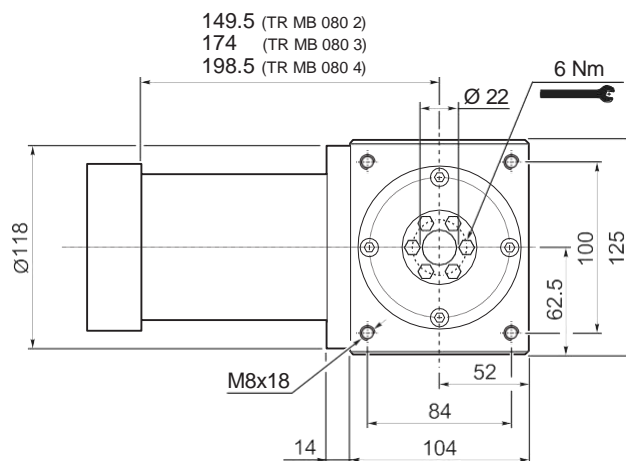
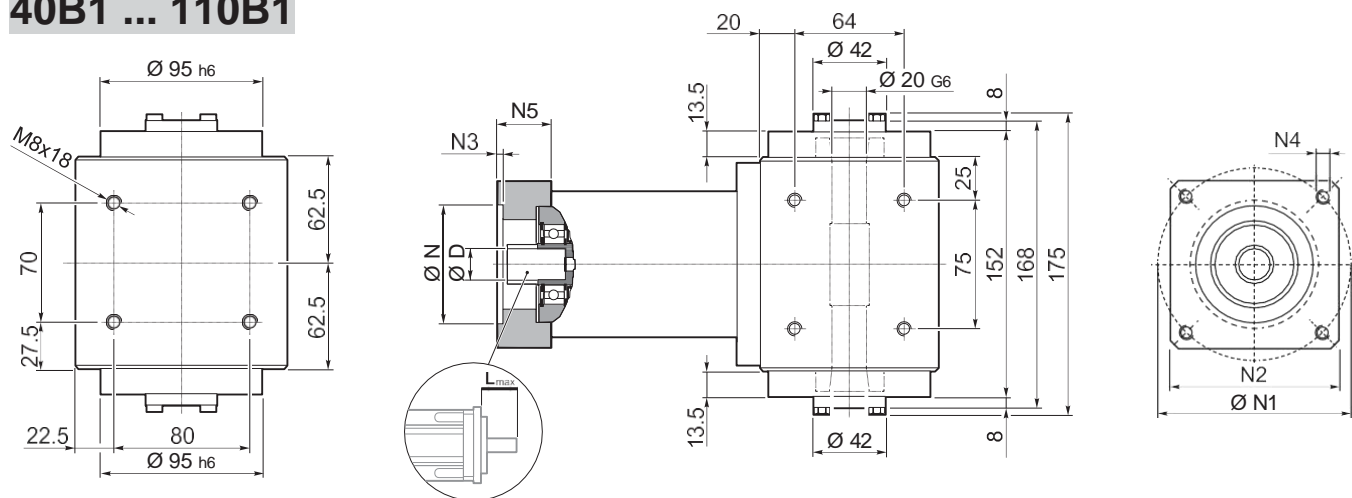

TR MB 080 2	9.5
TR MB 080 3	10.5
TR MB 080 4	11.5

												N	N1	N2	N3	N4	N5	L _{max}	
40B1	8	9	9.52	11	12	12.7	14	-	-	-	-	40	63	80	4	M4x12	34	40	
45A	8	9	9.52	11	12	12.7	-	-	-	-	-	45	63	80	4	M4x12	34	40	
50B1	8	9	9.52	11	12	12.7	14	-	-	-	-	50	65	80	4	M5x16	34	40	
50BH1	8	9	9.52	11	12	12.7	14	-	-	-	-	50	65	80	4	5.5	34	40	
50C1	8	9	9.52	11	12	12.7	14	-	-	-	-	50	70	80	4	M4x10	34	40	
50D	8	9	9.52	11	12	12.7	14	-	-	-	-	50	95	80	4	M6x20	34	40	
55A	8	9	9.52	11	12	12.7	14	15.875	16	17	19	19.05	55.5	125.7	105	4	M6x20	34	40
60A2	8	9	9.52	11	12	12.7	14	-	-	-	-	60	75	80	4	M5x16	34	40	
60AH2	8	9	9.52	11	12	12.7	14	-	-	-	-	60	75	90	4	6.5	34	40	
60B1	8	9	9.52	11	12	12.7	14	15.875	16	-	-	60	85	80	4	M5x16	34	40	
60C1	8	9	9.52	11	12	12.7	14	15.875	16	-	-	60	90	80	4	M5x16	34	40	
70A1	8	9	9.52	11	12	12.7	14	15.875	16	17	19	19.05	70	85	80	4	M6x20	34	40
70AH1	8	9	9.52	11	12	12.7	14	15.875	16	17	19	19.05	70	85	90	4	6.5	34	40
70B1	8	9	9.52	11	12	12.7	14	15.875	16	17	19	19.05	70	90	80	4	M5x16	34	40
73A1	8	9	9.52	11	12	12.7	14	-	-	-	-	73	98.4	85	4	M5x16	34	40	
80A1	8	9	9.52	11	12	12.7	14	15.875	16	17	19	19.05	80	100	90	4	M6x16	34	40
95A	8	9	9.52	11	12	12.7	14	15.875	16	17	19	19.05	95	115	100	4	M8x20	34	40
95B	8	9	9.52	11	12	12.7	14	15.875	16	17	19	19.05	95	130	115	4	M8x20	34	40
110A	8	9	9.52	11	12	12.7	14	15.875	16	17	19	19.05	110	130	115	4	M8x20	34	40
110B	8	9	9.52	11	12	12.7	14	15.875	16	17	19	19.05	110	145	120	6.5	M8x20	44	50
110B1	8	9	9.52	11	12	12.7	14	15.875	16	17	19	19.05	110	145	120	6.5	M8x20	54	60

TR MB 080

FM

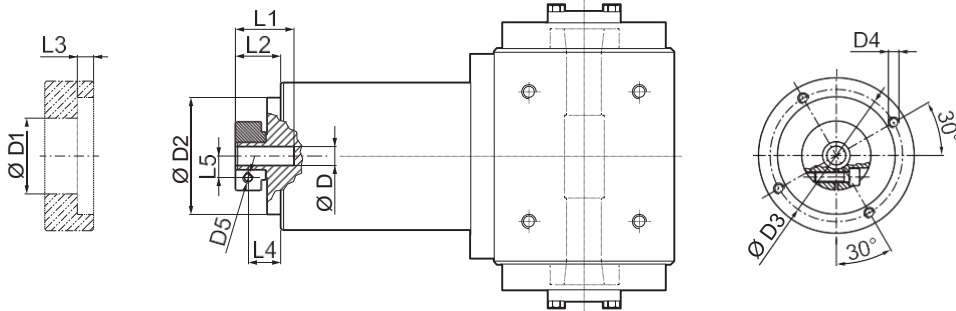

D				D1	D2	D3	D4	D5	L1	L2	L3	L4	L5
8	9	9.52		38	68	76.5	M6x12	M6	32.2	26.3	9.5	19.3	10.5
11	12	12.7		43	68	76.5	M6x12	M6	32.2	26.3	9.5	19.3	12.5
14	15.875	16	17	48	68	76.5	M6x12	M6	32.2	26.3	9.5	19.3	14.5
19	19.05			51	68	76.5	M6x12	M6	32.2	26.3	9.5	19.3	16.5

i	M_{n2} [Nm]	M_{a2} [Nm]	M_{p2} [Nm]	n_1 [min ⁻¹]	n_{1max} [min ⁻¹]	ϕ_S [arcmin]	ϕ_R [arcmin]	C_t [Nm/arcmin]	η %	J_G [kgcm ²]	
										8 ... 12.7	14 ... 19.05
TR MB 080 2 3	40	80	180	2900	3500	5'	3'	8.0	94	0.50	0.59
TR MB 080 2 4	50	80	200	3100	4500	5'	3'	8.0	94	0.34	0.43
TR MB 080 2 5	50	80	200	3200	4500	5'	3'	8.0	94	0.28	0.37
TR MB 080 2 6	50	80	200	3200	4500	5'	3'	8.0	94	0.21	0.30
TR MB 080 2 7	50	80	200	4000	6000	5'	3'	8.0	94	0.23	0.32
TR MB 080 2 10	40	80	180	4000	6000	5'	3'	8.0	94	0.20	0.29
TR MB 080 3 9	40	80	180	2900	3500	5'	3'	6.5	91	0.49	0.58
TR MB 080 3 12	70	100	250	2900	3500	5'	3'	6.5	91	0.47	0.56
TR MB 080 3 15	70	100	250	2900	3500	5'	3'	6.5	91	0.46	0.55
TR MB 080 3 16	70	100	250	3100	4500	5'	3'	6.5	91	0.32	0.41
TR MB 080 3 20	70	100	250	3200	4500	5'	3'	6.5	91	0.27	0.36
TR MB 080 3 25	70	100	250	3200	4500	5'	3'	6.5	91	0.27	0.36
TR MB 080 3 28	70	100	250	4000	6000	5'	3'	6.5	91	0.22	0.31
TR MB 080 3 30	40	80	180	4000	6000	5'	3'	6.5	91	0.20	0.29
TR MB 080 3 35	70	100	250	4000	6000	5'	3'	6.5	91	0.22	0.31
TR MB 080 3 36	50	80	200	3200	4500	5'	3'	6.5	91	0.20	0.29
TR MB 080 3 40	70	100	250	4000	6000	5'	3'	6.5	91	0.20	0.29
TR MB 080 3 50	70	100	250	4000	6000	5'	3'	6.5	91	0.19	0.28
TR MB 080 3 70	70	100	250	4000	6000	5'	3'	6.5	91	0.19	0.28
TR MB 080 3 100	40	80	180	4000	6000	5'	3'	6.5	91	0.19	0.28
TR MB 080 4 48	70	100	250	3100	4500	7'	5'	5.5	89	0.33	0.42
TR MB 080 4 64	70	100	250	3100	4500	7'	5'	5.5	89	0.32	0.41
TR MB 080 4 75	70	100	250	3200	4500	7'	5'	5.5	89	0.27	0.36
TR MB 080 4 80	70	100	250	3100	4500	7'	5'	5.5	89	0.32	0.41
TR MB 080 4 84	70	100	250	4000	6000	7'	5'	5.5	89	0.23	0.32
TR MB 080 4 90	40	80	180	4000	6000	7'	5'	5.5	89	0.20	0.29
TR MB 080 4 120	70	100	250	4000	6000	7'	5'	5.5	89	0.20	0.29
TR MB 080 4 125	70	100	250	3200	4500	7'	5'	5.5	89	0.27	0.36
TR MB 080 4 140	70	100	250	4000	6000	7'	5'	5.5	89	0.22	0.31
TR MB 080 4 150	70	100	250	4000	6000	7'	5'	5.5	89	0.20	0.29
TR MB 080 4 160	70	100	250	4000	6000	7'	5'	5.5	89	0.20	0.29
TR MB 080 4 175	70	100	250	4000	6000	7'	5'	5.5	89	0.22	0.31
TR MB 080 4 200	70	100	250	4000	6000	7'	5'	5.5	89	0.20	0.29
TR MB 080 4 210	70	100	250	4000	6000	7'	5'	5.5	89	0.20	0.29
TR MB 080 4 216	70	100	250	3200	4500	7'	5'	5.5	89	0.20	0.29
TR MB 080 4 250	70	100	250	4000	6000	7'	5'	5.5	89	0.19	0.28
TR MB 080 4 280	70	100	250	4000	6000	7'	5'	5.5	89	0.19	0.28
TR MB 080 4 350	70	100	250	4000	6000	7'	5'	5.5	89	0.19	0.28
TR MB 080 4 400	70	100	250	4000	6000	7'	5'	5.5	89	0.19	0.28
TR MB 080 4 500	70	100	250	4000	6000	7'	5'	5.5	89	0.19	0.28
TR MB 080 4 700	70	100	250	4000	6000	7'	5'	5.5	89	0.19	0.28
TR MB 080 4 1000	40	80	180	4000	6000	7'	5'	5.5	89	0.19	0.28

Please contact us for different motor adapters and input shaft bore.

TR 105

FM

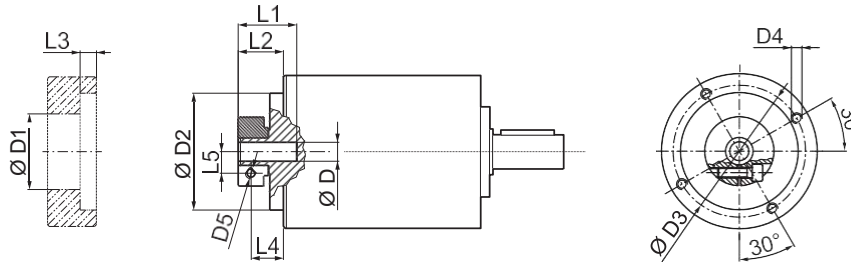

D				D1	D2	D3	D4	D5	L1	L2	L3	L4	L5
11	12	12.7		43	90	98	M6x15	M6	31.5	19.5	7.6	12	12.5
14	15	15.875	16	48	90	98	M6x15	M6	31.5	19.5	7.6	12	14.5
19				51	90	98	M6x15	M6	31.5	19.5	7.6	12	16.5
22	24			56.5	90	98	M6x15	M6	35	23	7.6	12	19
28				67	90	98	M6x15	M8	35	23	7.6	14	22.5
32				71	90	98	M6x15	M8	37	25	7.6	16	24.5

 i	M _{n 2} [Nm]	M _{a 2} [Nm]	M _{p 2} [Nm]	n ₁ [min ⁻¹]	n _{1 max} [min ⁻¹]	φ _S [arcmin]	φ _R [arcmin]	C _t Nm arcmin	R _{1 max} [N]	R _{2 max} [N]	A _{2 max} [N]	η %	J _G [kgcm ²]			
													D			
													11 ... 12.7	14 ... 19	22 - 24	28 - 32
TR 105 1 3	100	180	360	2500	3500	5'	3'	24.0	600	3800	4000	97	1.70	1.78	2.22	2.59
TR 105 1 4	140	210	450	2800	4500	5'	3'	24.0	600	3800	4000	97	0.99	1.06	1.51	1.87
TR 105 1 5	140	210	450	3000	4500	5'	3'	24.0	600	3800	4000	97	0.72	0.79	1.23	1.60
TR 105 1 6	140	210	450	3000	4500	5'	3'	24.0	600	3800	4000	97	0.36	0.43	0.88	1.24
TR 105 1 7	140	210	450	3500	5000	5'	3'	24.0	600	3800	4000	97	0.47	0.55	0.99	1.35
TR 105 1 10	100	180	360	3500	5000	5'	3'	24.0	600	3800	4000	97	0.33	0.41	0.85	1.21
TR 105 2 9	100	180	360	2500	3500	5'	3'	21.5	600	3800	4000	94	1.58	1.63	2.07	2.44
TR 105 2 12	170	250	600	2500	3500	5'	3'	21.5	600	3800	4000	94	1.52	1.59	2.03	2.40
TR 105 2 15	170	250	600	2500	3500	5'	3'	21.5	600	3800	4000	94	1.47	1.55	1.99	2.36
TR 105 2 16	170	250	600	2800	4500	5'	3'	21.5	600	3800	4000	94	0.87	0.95	1.39	1.76
TR 105 2 20	170	250	600	3000	4500	5'	3'	21.5	600	3800	4000	94	0.86	0.93	1.37	1.74
TR 105 2 25	170	250	600	3000	4500	5'	3'	21.5	600	3800	4000	94	0.63	0.71	1.15	1.51
TR 105 2 28	170	250	600	3500	5000	5'	3'	21.5	600	3800	4000	94	0.43	0.51	0.95	1.32
TR 105 2 30	100	180	360	3500	5000	5'	3'	21.5	600	3800	4000	94	0.32	0.40	0.84	1.20
TR 105 2 35	170	250	600	3500	5000	5'	3'	21.5	600	3800	4000	94	0.43	0.50	0.95	1.31
TR 105 2 36	140	210	450	3000	4500	5'	3'	21.5	600	3800	4000	94	0.32	0.39	0.84	1.20
TR 105 2 40	170	250	600	3500	5000	5'	3'	21.5	600	3800	4000	94	0.31	0.39	0.83	1.20
TR 105 2 50	170	250	600	3500	5000	5'	3'	21.5	600	3800	4000	94	0.31	0.39	0.83	1.19
TR 105 2 70	170	250	600	3500	5000	5'	3'	21.5	600	3800	4000	94	0.31	0.38	0.83	1.19
TR 105 2 100	100	180	360	3500	5000	5'	3'	21.5	600	3800	4000	94	0.31	0.38	0.83	1.19
TR 105 3 48	170	250	600	2800	4500	7'	5'	18.0	600	3800	4000	91	0.91	0.98	1.42	1.79
TR 105 3 64	170	250	600	2800	4500	7'	5'	18.0	600	3800	4000	91	0.87	0.94	1.38	1.75
TR 105 3 75	170	250	600	3000	4500	7'	5'	18.0	600	3800	4000	91	0.66	0.74	1.18	1.55
TR 105 3 80	170	250	600	2800	4500	7'	5'	18.0	600	3800	4000	91	0.86	0.94	1.38	1.75
TR 105 3 84	170	250	600	3500	5000	7'	5'	18.0	600	3800	4000	91	0.44	0.52	0.96	1.33
TR 105 3 90	100	180	360	3500	5000	7'	5'	18.0	600	3800	4000	91	0.32	0.39	0.84	1.20
TR 105 3 120	170	250	600	3500	5000	7'	5'	18.0	600	3800	4000	91	0.32	0.39	0.84	1.20
TR 105 3 125	170	250	600	3000	4500	7'	5'	18.0	600	3800	4000	91	0.63	0.70	1.15	1.51
TR 105 3 140	170	250	600	3500	5000	7'	5'	18.0	600	3800	4000	91	0.43	0.51	0.95	1.32
TR 105 3 150	170	250	600	3500	5000	7'	5'	18.0	600	3800	4000	91	0.32	0.39	0.84	1.20
TR 105 3 160	170	250	600	3500	5000	7'	5'	18.0	600	3800	4000	91	0.31	0.39	0.83	1.21
TR 105 3 175	170	250	600	3500	5000	7'	5'	18.0	600	3800	4000	91	0.43	0.50	0.95	1.31
TR 105 3 200	170	250	600	3500	5000	7'	5'	18.0	600	3800	4000	91	0.31	0.39	0.83	1.20
TR 105 3 210	170	250	600	3500	5000	7'	5'	18.0	600	3800	4000	91	0.32	0.39	0.84	1.20
TR 105 3 216	170	250	600	3000	4500	7'	5'	18.0	600	3800	4000	91	0.31	0.39	0.83	1.20
TR 105 3 250	170	250	600	3500	5000	7'	5'	18.0	600	3800	4000	91	0.31	0.39	0.83	1.19
TR 105 3 280	170	250	600	3500	5000	7'	5'	18.0	600	3800	4000	91	0.31	0.38	0.83	1.19
TR 105 3 350	170	250	600	3500	5000	7'	5'	18.0	600	3800	4000	91	0.31	0.38	0.83	1.19
TR 105 3 400	170	250	600	3500	5000	7'	5'	18.0	600	3800	4000	91	0.31	0.38	0.83	1.19
TR 105 3 500	170	250	600	3500	5000	7'	5'	18.0	600	3800	4000	91	0.31	0.38	0.83	1.19
TR 105 3 700	170	250	600	3500	5000	7'	5'	18.0	600	3800	4000	91	0.31	0.38	0.83	1.19
TR 105 3 1000	100	180	360	3500	5000	7'	5'	18.0	600	3800	4000	91	0.31	0.38	0.83	1.19

Please contact us for different motor adapters and input shaft bore.

TR G 105

FM

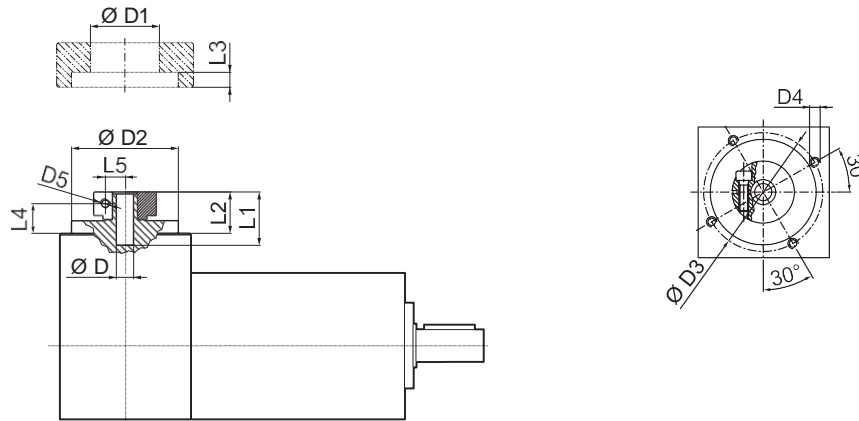

D				D1	D2	D3	D4	D5	L1	L2	L3	L4	L5
11	12	12.7		43	90	98	M6x15	M6	31.5	19.5	7.6	12	12.5
14	15	15.875	16	48	90	98	M6x15	M6	31.5	19.5	7.6	12	14.5
19				51	90	98	M6x15	M6	31.5	19.5	7.6	12	16.5
22	24			56.5	90	98	M6x15	M6	35	23	7.6	12	19
28				67	90	98	M6x15	M8	35	23	7.6	14	22.5
32				71	90	98	M6x15	M8	37	25	7.6	16	24.5

TR

 i	M _{n 2}	M _{a 2}	M _{p 2}	n ₁	n _{1 max}	ϕ _S	ϕ _R	C _t	R _{2 max}	A _{2 max}	η	J _G [kgcm ²]			
	[Nm]	[Nm]	[Nm]	[min ⁻¹]	[min ⁻¹]	[arcmin]		$\frac{Nm}{arcmin}$	[N]	[N]	%	11 ... 12.7	14 ... 19	22 - 24	28 - 32
TR G 105 2 3	100	180	360	2500	3500	5'	3'	24.0	3800	4000	94	1.85	2.01	2.33	3.07
TR G 105 2 4	140	210	450	2800	4500	5'	3'	24.0	3800	4000	94	1.14	1.29	1.62	2.35
TR G 105 2 5	140	210	450	3000	4500	5'	3'	24.0	3800	4000	94	1.07	1.21	1.34	2.08
TR G 105 2 6	140	210	450	3000	4500	5'	3'	24.0	3800	4000	94	0.87	1.02	1.16	1.89
TR G 105 2 7	140	210	450	3500	5000	5'	3'	24.0	3800	4000	94	0.98	1.14	1.27	2.00
TR G 105 2 10	100	180	360	3500	5000	5'	3'	24.0	3800	4000	94	0.94	1.09	1.23	1.95
TR G 105 3 9	100	180	360	2500	3500	5'	3'	21.5	3800	4000	91	1.76	1.86	2.18	2.92
TR G 105 3 12	170	250	600	2500	3500	5'	3'	21.5	3800	4000	91	1.60	1.75	2.14	2.88
TR G 105 3 15	170	250	600	2500	3500	5'	3'	21.5	3800	4000	91	1.57	1.73	2.10	2.84
TR G 105 3 16	170	250	600	2800	4500	5'	3'	21.5	3800	4000	91	1.02	1.18	1.50	2.24
TR G 105 3 20	170	250	600	3000	4500	5'	3'	21.5	3800	4000	91	1.20	1.35	1.48	2.22
TR G 105 3 25	170	250	600	3000	4500	5'	3'	21.5	3800	4000	91	1.13	1.29	1.42	2.15
TR G 105 3 28	170	250	600	3500	5000	5'	3'	21.5	3800	4000	91	0.94	1.10	1.23	1.97
TR G 105 3 30	100	180	360	3500	5000	5'	3'	21.5	3800	4000	91	0.93	1.08	1.22	1.94
TR G 105 3 35	170	250	600	3500	5000	5'	3'	21.5	3800	4000	91	1.02	1.17	1.31	2.04
TR G 105 3 36	140	210	450	3000	4500	5'	3'	21.5	3800	4000	91	0.83	0.98	1.12	1.85
TR G 105 3 40	170	250	600	3500	5000	5'	3'	21.5	3800	4000	91	0.96	1.11	1.25	1.98
TR G 105 3 50	170	250	600	3500	5000	5'	3'	21.5	3800	4000	91	0.96	1.11	1.25	1.98
TR G 105 3 70	170	250	600	3500	5000	5'	3'	21.5	3800	4000	91	0.92	1.06	1.21	1.93
TR G 105 3 100	100	180	360	3500	5000	5'	3'	21.5	3800	4000	91	0.92	1.06	1.21	1.93
TR G 105 4 48	170	250	600	2800	4500	7'	5'	18.0	3800	4000	89	1.06	1.21	1.53	2.27
TR G 105 4 64	170	250	600	2800	4500	7'	5'	18.0	3800	4000	89	1.02	1.17	1.49	2.23
TR G 105 4 75	170	250	600	3000	4500	7'	5'	18.0	3800	4000	89	1.00	1.16	1.29	2.03
TR G 105 4 80	170	250	600	2800	4500	7'	5'	18.0	3800	4000	89	1.01	1.17	1.49	2.23
TR G 105 4 84	170	250	600	3500	5000	7'	5'	18.0	3800	4000	89	0.95	1.11	1.24	1.98
TR G 105 4 90	100	180	360	3500	5000	7'	5'	18.0	3800	4000	89	0.93	1.07	1.22	1.94
TR G 105 4 120	170	250	600	3500	5000	7'	5'	18.0	3800	4000	89	0.93	1.07	1.22	1.94
TR G 105 4 125	170	250	600	3000	4500	7'	5'	18.0	3800	4000	89	0.97	1.12	1.26	1.99
TR G 105 4 140	170	250	600	3500	5000	7'	5'	18.0	3800	4000	89	0.94	1.10	1.23	1.97
TR G 105 4 150	170	250	600	3500	5000	7'	5'	18.0	3800	4000	89	0.93	1.07	1.22	1.94
TR G 105 4 160	170	250	600	3500	5000	7'	5'	18.0	3800	4000	89	0.92	1.07	1.21	1.96
TR G 105 4 175	170	250	600	3500	5000	7'	5'	18.0	3800	4000	89	0.94	1.09	1.23	1.96
TR G 105 4 200	170	250	600	3500	5000	7'	5'	18.0	3800	4000	89	0.92	1.07	1.21	1.94
TR G 105 4 210	170	250	600	3500	5000	7'	5'	18.0	3800	4000	89	0.93	1.07	1.22	1.94
TR G 105 4 216	170	250	600	3000	4500	7'	5'	18.0	3800	4000	89	0.83	0.98	1.11	1.85
TR G 105 4 250	170	250	600	3500	5000	7'	5'	18.0	3800	4000	89	0.92	1.07	1.21	1.93
TR G 105 4 280	170	250	600	3500	5000	7'	5'	18.0	3800	4000	89	0.92	1.06	1.21	1.93
TR G 105 4 350	170	250	600	3500	5000	7'	5'	18.0	3800	4000	89	0.92	1.06	1.21	1.93
TR G 105 4 400	170	250	600	3500	5000	7'	5'	18.0	3800	4000	89	0.92	1.06	1.21	1.93
TR G 105 4 500	170	250	600	3500	5000	7'	5'	18.0	3800	4000	89	0.92	1.06	1.21	1.93
TR G 105 4 700	170	250	600	3500	5000	7'	5'	18.0	3800	4000	89	0.92	1.06	1.21	1.93
TR G 105 4 1000	100	180	360	3500	5000	7'	5'	18.0	3800	4000	89	0.92	1.06	1.21	1.93

Please contact us for different motor adapters and input shaft bore.

TR MB 105

50D ... 130A1

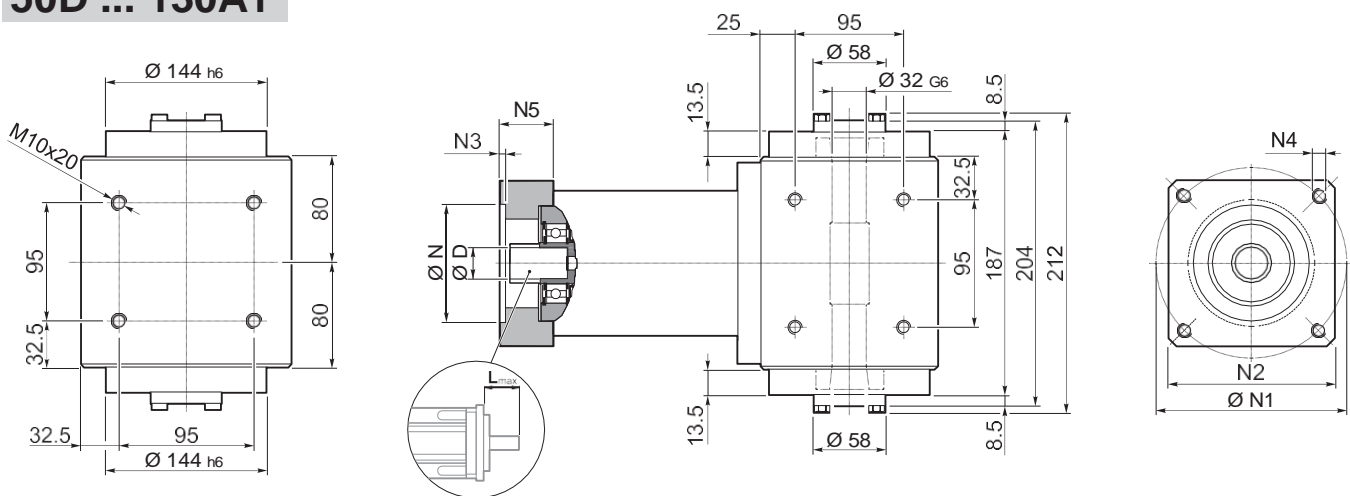

TR

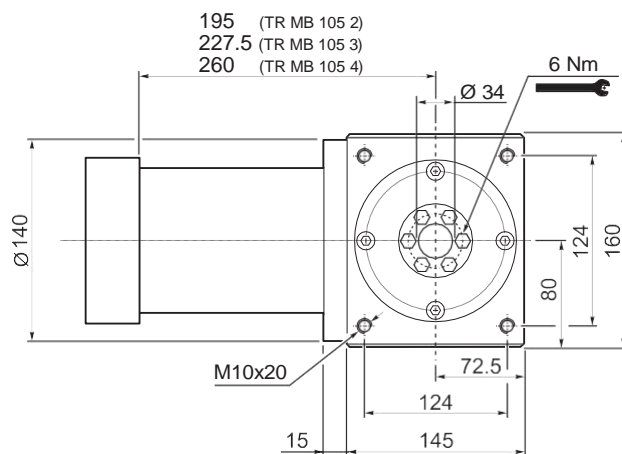

TR MB 105 2	19.2
TR MB 105 3	21.2
TR MB 105 4	23.2

											N	N1	N2	N3	N4	N5	L _{max}	
50D	11	12	12.7	14	15	15.875	16	19	-	-	-	50	95	100	5	M6x14	28	40
55A	11	12	12.7	14	15	15.875	16	19	-	-	-	55	125.7	105	5	M6x16	28	40
60A2	11	12	12.7	14	15	15.875	16	19	-	-	-	60	75	100	6.5	M5x14	28	40
60AH2	11	12	12.7	14	15	15.875	16	19	-	-	-	60	75	100	4	6.5	33	40
60B1	11	12	12.7	14	15	15.875	16	19	-	-	-	60	85	100	6.5	M5x14	28	40
70A1	11	12	12.7	14	15	15.875	16	19	-	-	-	70	85	100	6.5	M6x14	28	40
70AH1	11	12	12.7	14	15	15.875	16	19	-	-	-	70	85	100	4	6.5	33	40
70B1	11	12	12.7	14	15	15.875	16	19	-	-	-	70	90	100	6.5	M5x12	28	40
80A1	11	12	12.7	14	15	15.875	16	19	-	-	-	80	100	100	6.5	M6x16	28	40
80AH1	11	12	12.7	14	15	15.875	16	19	-	-	-	80	100	100	4	6.5	33	40
95A	11	12	12.7	14	15	15.875	16	19	-	-	-	95	115	100	6.5	M8x18	28	40
95A1	11	12	12.7	14	15	15.875	16	19	22	24	-	95	115	100	6.5	M8x18	38	50
95B	11	12	12.7	14	15	15.875	16	19	-	-	-	95	130	115	6.5	M8x18	28	40
110A	11	12	12.7	14	15	15.875	16	19	-	-	-	110	130	115	6.5	M8x18	28	40
110A1	11	12	12.7	14	15	15.875	16	19	22	24	-	110	130	115	6.5	M8x20	38	50
110B	11	12	12.7	14	15	15.875	16	19	22	24	-	110	145	120	6.5	M8x20	38	50
110B1	11	12	12.7	14	15	15.875	16	19	22	24	28	110	145	120	6.5	M8x20	48	60
130A	11	12	12.7	14	15	15.875	16	19	22	24	-	130	165	140	6.5	M10x20	38	50
130A1	11	12	12.7	14	15	15.875	16	19	22	24	28	130	165	140	6.5	M10x25	48	60

TR MB 105

FM

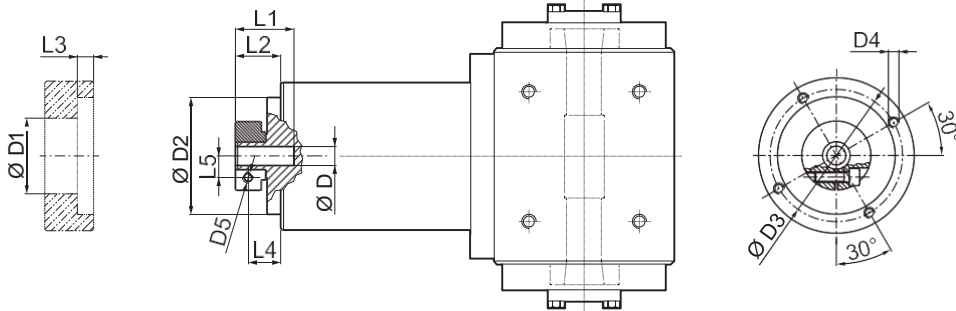

D				D1	D2	D3	D4	D5	L1	L2	L3	L4	L5
11	12	12.7		43	90	98	M6x15	M6	31.5	19.5	7.6	12	12.5
14	15	15.875	16	48	90	98	M6x15	M6	31.5	19.5	7.6	12	14.5
19				51	90	98	M6x15	M6	31.5	19.5	7.6	12	16.5
22	24			56.5	90	98	M6x15	M6	35	23	7.6	12	19
28				67	90	98	M6x15	M8	35	23	7.6	14	22.5
32				71	90	98	M6x15	M8	37	25	7.6	16	24.5

i	M _{n2} [Nm]	M _{a2} [Nm]	M _{p2} [Nm]	n ₁ [min ⁻¹]	n _{1 max} [min ⁻¹]	φ _S [arcmin]	φ _R [arcmin]	C _t [Nm/arcmin]	η %	J _G [kgcm ²]			
										D			
										11 ... 12.7	14 ... 19	22 - 24	28 - 32
TR MB 105 2 3	100	180	360	2500	3500	5'	3'	24.0	94	1.70	1.78	2.22	2.59
TR MB 105 2 4	140	210	450	2800	4500	5'	3'	24.0	94	0.99	1.06	1.51	1.87
TR MB 105 2 5	140	210	450	3000	4500	5'	3'	24.0	94	0.72	0.79	1.23	1.60
TR MB 105 2 6	140	210	450	3000	4500	5'	3'	24.0	94	0.36	0.43	0.88	1.24
TR MB 105 2 7	140	210	450	3500	5000	5'	3'	24.0	94	0.47	0.55	0.99	1.35
TR MB 105 2 10	100	180	360	3500	5000	5'	3'	24.0	94	0.33	0.41	0.85	1.21
TR MB 105 3 9	100	180	360	2500	3500	5'	3'	21.5	91	1.58	1.63	2.07	2.44
TR MB 105 3 12	170	250	600	2500	3500	5'	3'	21.5	91	1.52	1.59	2.03	2.40
TR MB 105 3 15	170	250	600	2500	3500	5'	3'	21.5	91	1.47	1.55	1.99	2.36
TR MB 105 3 16	170	250	600	2800	4500	5'	3'	21.5	91	0.87	0.95	1.39	1.76
TR MB 105 3 20	170	250	600	3000	4500	5'	3'	21.5	91	0.86	0.93	1.37	1.74
TR MB 105 3 25	170	250	600	3000	4500	5'	3'	21.5	91	0.63	0.71	1.15	1.51
TR MB 105 3 28	170	250	600	3500	5000	5'	3'	21.5	91	0.43	0.51	0.95	1.32
TR MB 105 3 30	100	180	360	3500	5000	5'	3'	21.5	91	0.32	0.40	0.84	1.20
TR MB 105 3 35	170	250	600	3500	5000	5'	3'	21.5	91	0.43	0.50	0.95	1.31
TR MB 105 3 36	140	210	450	3000	4500	5'	3'	21.5	91	0.32	0.39	0.84	1.20
TR MB 105 3 40	170	250	600	3500	5000	5'	3'	21.5	91	0.31	0.39	0.83	1.20
TR MB 105 3 50	170	250	600	3500	5000	5'	3'	21.5	91	0.31	0.39	0.83	1.19
TR MB 105 3 70	170	250	600	3500	5000	5'	3'	21.5	91	0.31	0.38	0.83	1.19
TR MB 105 3 100	100	180	360	3500	5000	5'	3'	21.5	91	0.31	0.38	0.83	1.19
TR MB 105 4 48	170	250	600	2800	4500	7'	5'	18.0	89	0.91	0.98	1.42	1.79
TR MB 105 4 64	170	250	600	2800	4500	7'	5'	18.0	89	0.87	0.94	1.38	1.75
TR MB 105 4 75	170	250	600	3000	4500	7'	5'	18.0	89	0.66	0.74	1.18	1.55
TR MB 105 4 80	170	250	600	2800	4500	7'	5'	18.0	89	0.86	0.94	1.38	1.75
TR MB 105 4 84	170	250	600	3500	5000	7'	5'	18.0	89	0.44	0.52	0.96	1.33
TR MB 105 4 90	100	180	360	3500	5000	7'	5'	18.0	89	0.32	0.39	0.84	1.20
TR MB 105 4 120	170	250	600	3500	5000	7'	5'	18.0	89	0.32	0.39	0.84	1.20
TR MB 105 4 125	170	250	600	3000	4500	7'	5'	18.0	89	0.63	0.70	1.15	1.51
TR MB 105 4 140	170	250	600	3500	5000	7'	5'	18.0	89	0.43	0.51	0.95	1.32
TR MB 105 4 150	170	250	600	3500	5000	7'	5'	18.0	89	0.32	0.39	0.84	1.20
TR MB 105 4 160	170	250	600	3500	5000	7'	5'	18.0	89	0.31	0.39	0.83	1.21
TR MB 105 4 175	170	250	600	3500	5000	7'	5'	18.0	89	0.43	0.50	0.95	1.31
TR MB 105 4 200	170	250	600	3500	5000	7'	5'	18.0	89	0.31	0.39	0.83	1.20
TR MB 105 4 210	170	250	600	3500	5000	7'	5'	18.0	89	0.32	0.39	0.84	1.20
TR MB 105 4 216	170	250	600	3000	4500	7'	5'	18.0	89	0.31	0.39	0.83	1.20
TR MB 105 4 250	170	250	600	3500	5000	7'	5'	18.0	89	0.31	0.39	0.83	1.19
TR MB 105 4 280	170	250	600	3500	5000	7'	5'	18.0	89	0.31	0.38	0.83	1.19
TR MB 105 4 350	170	250	600	3500	5000	7'	5'	18.0	89	0.31	0.38	0.83	1.19
TR MB 105 4 400	170	250	600	3500	5000	7'	5'	18.0	89	0.31	0.38	0.83	1.19
TR MB 105 4 500	170	250	600	3500	5000	7'	5'	18.0	89	0.31	0.38	0.83	1.19
TR MB 105 4 700	170	250	600	3500	5000	7'	5'	18.0	89	0.31	0.38	0.83	1.19
TR MB 105 4 1000	100	180	360	3500	5000	7'	5'	18.0	89	0.31	0.38	0.83	1.19

Please contact us for different motor adapters and input shaft bore.

TR 130

IS

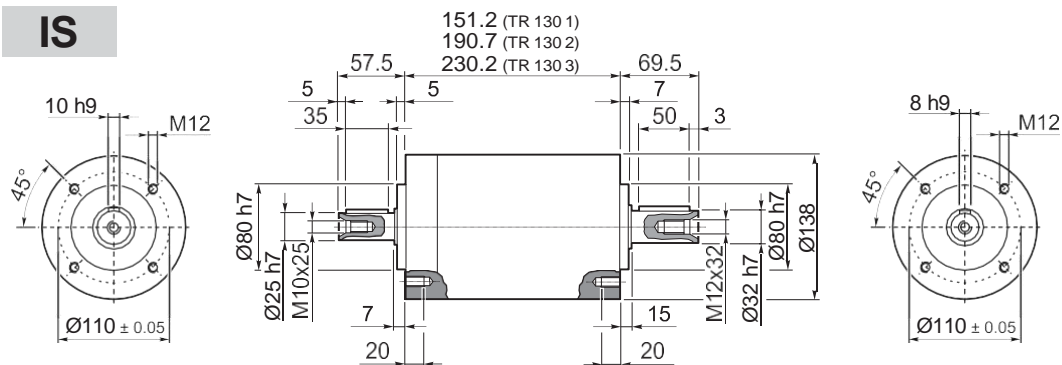

TR 130 1	12.0
TR 130 2	15.5
TR 130 3	18.5

TR

55A1 ... 180A1

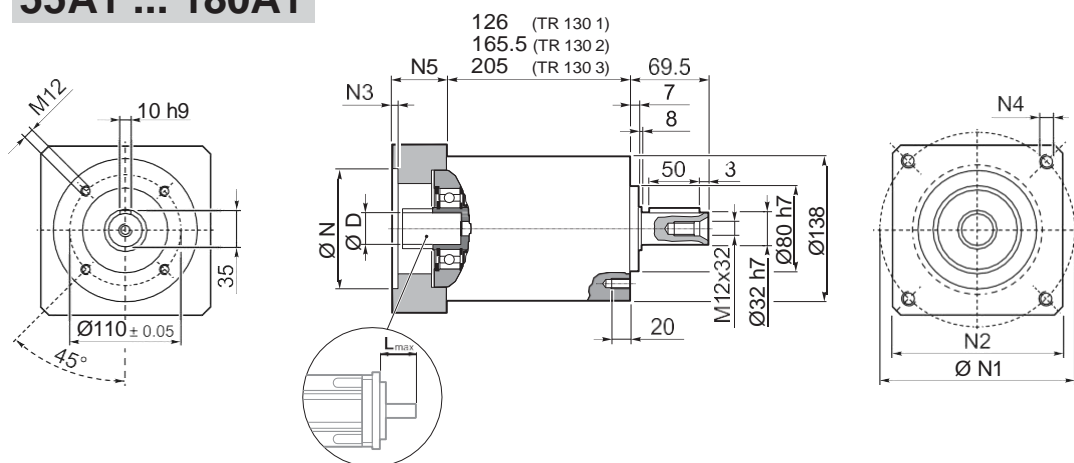

TR 130 1	12.0
TR 130 2	15.5
TR 130 3	18.5

											N	N1	N2	N3	N4	N5	L _{max}
55A1	14	15.875	16	19	-	-	-	-	-	-	55.5	125.7	130	4	M6x15	39.5	50
80A2	14	15.875	16	19	-	-	-	-	-	-	80	100	130	4	M6x15	39.5	50
95A1	14	15.875	16	19	22	24	-	-	-	-	95	115	130	4	M8x20	39.5	50
110A1	14	15.875	16	19	22	24	-	-	-	-	110	130	130	4	M8x20	39.5	50
110B1	14	15.875	16	19	22	24	-	-	-	-	110	145	130	6.5	M8x20	49.5	60
114A0	14	15.875	16	19	22	24	-	-	-	-	114.3	200	170	5.5	M12x25	39.5	50
114A	14	15.875	16	19	22	24	28	32	35	38	114.3	200	170	5.5	M12x25	69.5	80
130A	14	15.875	16	19	22	24	-	-	-	-	130	165	140	4	M10x20	39.5	50
130A1	14	15.875	16	19	22	24	28	32	-	-	130	165	140	4	M10x20	49.5	60
180A	14	15.875	16	19	22	24	28	32	-	-	180	215	190	5.5	M14x25	49.5	60
180A1	14	15.875	16	19	22	24	28	32	35	38	180	215	190	5.5	M14x25	69.5	80

TR 130

FM

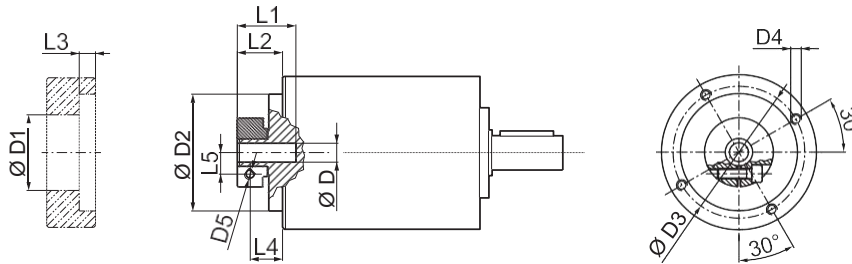

D			D1	D2	D3	D4	D5	L1	L2	L3	L4	L5
14	15.875	16	48	113	125.5	M8x15	M6	40	27.5	6	20	14.5
19			51	113	125.5	M8x15	M6	40	27.5	6	20	16.5
22	24		56.5	113	125.5	M8x15	M6	41	28.5	6	19.5	19
28			67	113	125.5	M8x15	M8	41	28.5	6	19.5	22.5
32			71	113	125.5	M8x15	M8	41	28.5	6	19.5	24.5
35			73	113	125.5	M8x15	M8	50	37.5	11.25	26	26
38			77.5	113	125.5	M8x15	M8	50	37.5	11.25	26	28

i	M _{n2} [Nm]	M _{a2} [Nm]	M _{p2} [Nm]	n ₁ [min ⁻¹]	n _{1 max} [min ⁻¹]	φ _S [arcmin]	φ _R [arcmin]	C _t [Nm/arcmin]	R _{1 max} [N]	R _{2 max} [N]	A _{2 max} [N]	η %	J _G [kgcm ²]			
													14 ... 19	22 - 24	28 - 32	35 - 38
TR 130 1_3	215	400	800	2100	3000	5'	3'	45.0	800	5500	6500	97	5.25	5.46	5.81	7.16
TR 130 1_4	380	600	1100	2400	3500	5'	3'	45.0	800	5500	6500	97	3.06	3.26	3.61	4.97
TR 130 1_5	380	600	1100	2900	3500	5'	3'	45.0	800	5500	6500	97	2.22	2.42	2.77	4.13
TR 130 1_6	380	600	1100	2900	3500	5'	3'	45.0	800	5500	6500	97	1.19	1.40	1.75	3.10
TR 130 1_7	380	600	1100	3200	4000	5'	3'	45.0	800	5500	6500	97	1.47	1.68	2.03	3.38
TR 130 1_10	215	400	800	3200	4000	5'	3'	45.0	800	5500	6500	97	1.04	1.25	1.60	2.95
TR 130 2_9	215	400	800	2100	3000	5'	3'	38.5	800	5500	6500	94	4.82	5.02	5.37	6.72
TR 130 2_12	450	700	1300	2100	3000	5'	3'	38.5	800	5500	6500	94	4.57	4.78	5.13	6.48
TR 130 2_15	450	700	1300	2100	3000	5'	3'	38.5	800	5500	6500	94	4.48	4.69	5.04	6.39
TR 130 2_16	450	700	1300	2400	3500	5'	3'	38.5	800	5500	6500	94	2.67	2.88	3.23	4.58
TR 130 2_20	450	700	1300	2900	3500	5'	3'	38.5	800	5500	6500	94	1.97	2.18	2.53	3.88
TR 130 2_25	450	700	1300	2900	3500	5'	3'	38.5	800	5500	6500	94	1.94	2.15	2.50	3.85
TR 130 2_28	450	700	1300	3200	4000	5'	3'	38.5	800	5500	6500	94	1.34	1.55	1.90	3.25
TR 130 2_30	215	400	800	3200	4000	5'	3'	38.5	800	5500	6500	94	1.00	1.21	1.56	2.91
TR 130 2_35	450	700	1300	3200	4000	5'	3'	38.5	800	5500	6500	94	1.33	1.53	1.88	3.24
TR 130 2_36	380	600	1100	2900	3500	5'	3'	38.5	800	5500	6500	94	1.05	1.26	1.61	2.96
TR 130 2_40	450	700	1300	3200	4000	5'	3'	38.5	800	5500	6500	94	0.98	1.19	1.54	2.89
TR 130 2_50	450	700	1300	3200	4000	5'	3'	38.5	800	5500	6500	94	0.97	1.18	1.53	2.88
TR 130 2_70	450	700	1300	3200	4000	5'	3'	38.5	800	5500	6500	94	0.96	1.17	1.52	2.87
TR 130 2_100	215	400	800	3200	4000	5'	3'	38.5	800	5500	6500	94	0.96	1.17	1.52	2.87
TR 130 3_48	450	700	1300	2400	3500	7'	5'	30.0	800	5500	6500	91	2.77	2.98	3.33	4.68
TR 130 3_64	450	700	1300	2400	3500	7'	5'	30.0	800	5500	6500	91	2.65	2.86	3.21	4.56
TR 130 3_75	450	700	1300	2900	3500	7'	5'	30.0	800	5500	6500	91	2.03	2.24	2.59	3.94
TR 130 3_80	450	700	1300	2400	3500	7'	5'	30.0	800	5500	6500	91	2.65	2.85	3.20	4.56
TR 130 3_84	450	700	1300	3200	4000	7'	5'	30.0	800	5500	6500	91	1.37	1.58	1.93	3.28
TR 130 3_90	215	400	800	3200	4000	7'	5'	30.0	800	5500	6500	91	1.00	1.20	1.55	2.91
TR 130 3_120	450	700	1300	3200	4000	7'	5'	30.0	800	5500	6500	91	0.99	1.20	1.55	2.90
TR 130 3_125	450	700	1300	2900	3500	7'	5'	30.0	800	5500	6500	91	1.93	2.13	2.48	3.84
TR 130 3_140	450	700	1300	3200	4000	7'	5'	30.0	800	5500	6500	91	1.34	1.54	1.89	3.25
TR 130 3_150	450	700	1300	3200	4000	7'	5'	30.0	800	5500	6500	91	0.99	1.20	1.55	2.90
TR 130 3_160	450	700	1300	3200	4000	7'	5'	30.0	800	5500	6500	91	0.98	1.18	1.53	2.89
TR 130 3_175	450	700	1300	3200	4000	7'	5'	30.0	800	5500	6500	91	1.32	1.53	1.88	3.23
TR 130 3_200	450	700	1300	3200	4000	7'	5'	30.0	800	5500	6500	91	0.97	1.18	1.53	2.88
TR 130 3_210	450	700	1300	3200	4000	7'	5'	30.0	800	5500	6500	91	0.99	1.20	1.55	2.90
TR 130 3_216	450	700	1300	2900	3500	7'	5'	30.0	800	5500	6500	91	1.05	1.26	1.61	2.96
TR 130 3_250	450	700	1300	3200	4000	7'	5'	30.0	800	5500	6500	91	0.97	1.18	1.53	2.88
TR 130 3_280	450	700	1300	3200	4000	7'	5'	30.0	800	5500	6500	91	0.96	1.17	1.52	2.87
TR 130 3_350	450	700	1300	3200	4000	7'	5'	30.0	800	5500	6500	91	0.96	1.17	1.52	2.87
TR 130 3_400	450	700	1300	3200	4000	7'	5'	30.0	800	5500	6500	91	0.96	1.17	1.52	2.87
TR 130 3_500	450	700	1300	3200	4000	7'	5'	30.0	800	5500	6500	91	0.96	1.17	1.52	2.87
TR 130 3_700	450	700	1300	3200	4000	7'	5'	30.0	800	5500	6500	91	0.96	1.17	1.52	2.87
TR 130 3_1000	215	400	800	3200	4000	7'	5'	30.0	800	5500	6500	91	0.96	1.17	1.52	2.87

Please contact us for different motor adapters and input shaft bore.

TR G 130

55A1 ... 180A1

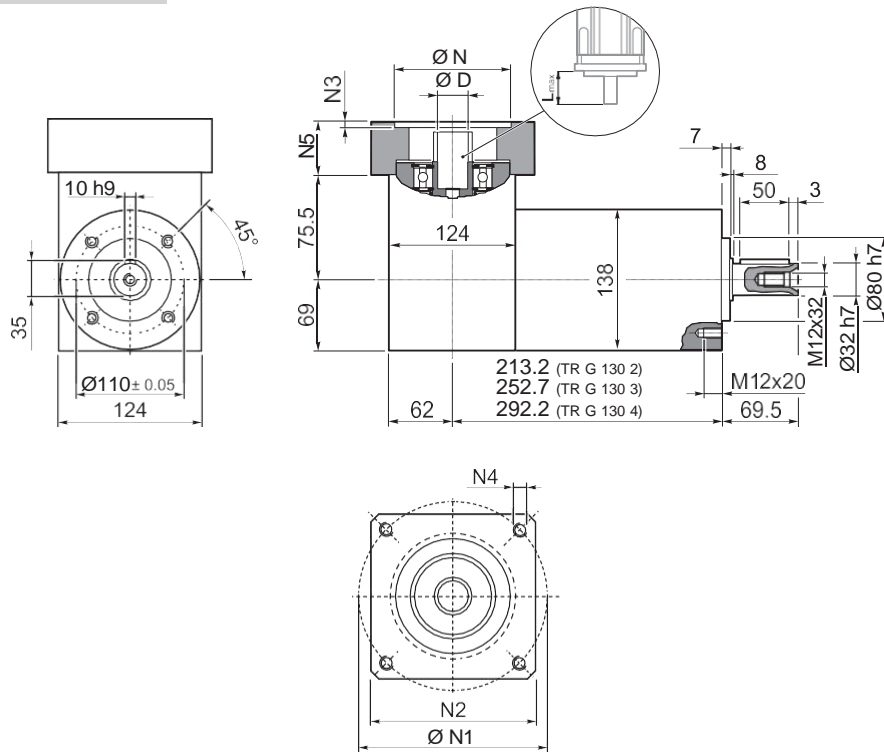

TR

											N	N1	N2	N3	N4	N5	L _{max}
	14	15.875	16	19	-	-	-	-	-	-							
55A1	14	15.875	16	19	-	-	-	-	-	-	55.5	125.7	130	4	M6x15	39.5	50
80A2	14	15.875	16	19	-	-	-	-	-	-	80	100	130	4	M6x15	39.5	50
95A1	14	15.875	16	19	22	24	-	-	-	-	95	115	130	4	M8x20	39.5	50
110A1	14	15.875	16	19	22	24	-	-	-	-	110	130	130	4	M8x20	39.5	50
110B1	14	15.875	16	19	22	24	-	-	-	-	110	145	130	6.5	M8x20	49.5	60
114A0	14	15.875	16	19	22	24	-	-	-	-	114.3	200	170	5.5	M12x25	39.5	50
114A	14	15.875	16	19	22	24	28	32	35	38	114.3	200	170	5.5	M12x25	69.5	80
130A	14	15.875	16	19	22	24	-	-	-	-	130	165	140	4	M10x20	39.5	50
130A1	14	15.875	16	19	22	24	28	32	-	-	130	165	140	4	M10x20	49.5	60
180A	14	15.875	16	19	22	24	28	32	-	-	180	215	190	5.5	M14x25	49.5	60
180A1	14	15.875	16	19	22	24	28	32	35	38	180	215	190	5.5	M14x25	69.5	80

TR G 130

FM

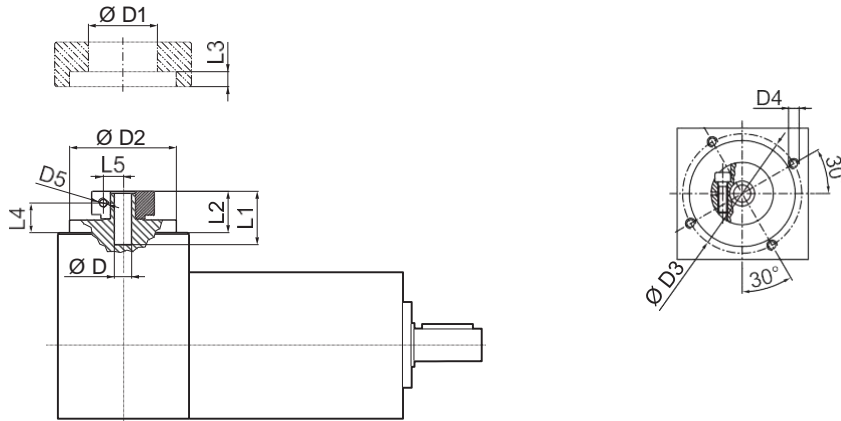

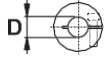
	D1	D2	D3	D4	D5	L1	L2	L3	L4	L5
14 15.875 16	48	113	125.5	M8x15	M6	40	27.5	6	20	14.5
19	51	113	125.5	M8x15	M6	40	27.5	6	20	16.5
22 24	56.5	113	125.5	M8x15	M6	41	28.5	6	19.5	19
28	67	113	125.5	M8x15	M8	41	28.5	6	19.5	22.5
32	71	113	125.5	M8x15	M8	41	28.5	6	19.5	24.5
35	73	113	125.5	M8x15	M8	50	37.5	11.25	26	26
38	77.5	113	125.5	M8x15	M8	50	37.5	11.25	26	28

TR

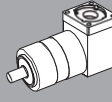
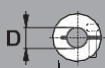
	i	M _{n2} [Nm]	M _{a2} [Nm]	M _{p2} [Nm]	n ₁ [min ⁻¹]	n _{1 max} [min ⁻¹]	ϕ _S [arcmin]	ϕ _R [arcmin]	C _t [Nm/arcmin]	R _{2 max} [N]	A _{2 max} [N]	η %	J _G [kgcm ²]			
														14 ... 19	22 - 24	28 - 32
TR G 130 2 3		215	400	800	2100	3000	5'	3'	45.0	5500	6500	94	7.09	7.28	7.66	10.37
TR G 130 2 4		380	600	1100	2400	3500	5'	3'	45.0	5500	6500	94	4.90	5.08	5.46	8.18
TR G 130 2 5		380	600	1100	2900	3500	5'	3'	45.0	5500	6500	94	4.81	4.99	5.38	8.10
TR G 130 2 6		380	600	1100	2900	3500	5'	3'	45.0	5500	6500	94	4.45	4.64	5.03	7.73
TR G 130 2 7		380	600	1100	3200	4000	5'	3'	45.0	5500	6500	94	4.73	4.92	5.31	8.01
TR G 130 2 10		215	400	800	3200	4000	5'	3'	45.0	5500	6500	94	4.68	4.88	5.26	7.97
TR G 130 3 9		215	400	800	2100	3000	5'	3'	38.5	5500	6500	91	6.66	6.84	7.22	9.93
TR G 130 3 12		450	700	1300	2100	3000	5'	3'	38.5	5500	6500	91	6.25	6.45	6.84	9.54
TR G 130 3 15		450	700	1300	2100	3000	5'	3'	38.5	5500	6500	91	6.25	6.44	6.83	9.53
TR G 130 3 16		450	700	1300	2400	3500	5'	3'	38.5	5500	6500	91	4.51	4.70	5.08	7.79
TR G 130 3 20		450	700	1300	2900	3500	5'	3'	38.5	5500	6500	91	4.56	5.36	5.75	8.45
TR G 130 3 25		450	700	1300	2900	3500	5'	3'	38.5	5500	6500	91	5.13	4.72	5.11	7.82
TR G 130 3 28		450	700	1300	3200	4000	5'	3'	38.5	5500	6500	91	4.60	4.79	5.18	7.88
TR G 130 3 30		215	400	800	3200	4000	5'	3'	38.5	5500	6500	91	4.64	4.84	5.22	7.93
TR G 130 3 35		450	700	1300	3200	4000	5'	3'	38.5	5500	6500	91	4.92	5.10	5.49	8.20
TR G 130 3 36		380	600	1100	2900	3500	5'	3'	38.5	5500	6500	91	4.31	4.50	4.89	7.59
TR G 130 3 40		450	700	1300	3200	4000	5'	3'	38.5	5500	6500	91	4.77	4.96	5.35	8.05
TR G 130 3 50		450	700	1300	3200	4000	5'	3'	38.5	5500	6500	91	4.76	4.96	5.34	8.05
TR G 130 3 70		450	700	1300	3200	4000	5'	3'	38.5	5500	6500	91	4.60	4.80	5.18	7.89
TR G 130 3 100		215	400	800	3200	4000	5'	3'	38.5	5500	6500	91	4.60	4.80	5.18	7.89
TR G 130 4 48		450	700	1300	2400	3500	7'	5'	30.0	5500	6500	89	4.61	4.81	5.18	7.89
TR G 130 4 64		450	700	1300	2400	3500	7'	5'	30.0	5500	6500	89	4.49	4.68	5.06	7.77
TR G 130 4 75		450	700	1300	2900	3500	7'	5'	30.0	5500	6500	89	4.62	4.81	5.20	7.91
TR G 130 4 80		450	700	1300	2400	3500	7'	5'	30.0	5500	6500	89	4.49	4.67	5.05	7.77
TR G 130 4 84		450	700	1300	3200	4000	7'	5'	30.0	5500	6500	89	4.63	4.82	5.21	7.91
TR G 130 4 90		215	400	800	3200	4000	7'	5'	30.0	5500	6500	89	4.64	4.83	5.21	7.93
TR G 130 4 120		450	700	1300	3200	4000	7'	5'	30.0	5500	6500	89	4.63	4.83	5.21	7.92
TR G 130 4 125		450	700	1300	2900	3500	7'	5'	30.0	5500	6500	89	4.52	4.70	5.09	7.81
TR G 130 4 140		450	700	1300	3200	4000	7'	5'	30.0	5500	6500	89	4.60	4.78	5.17	7.88
TR G 130 4 150		450	700	1300	3200	4000	7'	5'	30.0	5500	6500	89	4.63	4.83	5.21	7.92
TR G 130 4 160		450	700	1300	3200	4000	7'	5'	30.0	5500	6500	89	4.62	4.81	5.19	7.91
TR G 130 4 175		450	700	1300	3200	4000	7'	5'	30.0	5500	6500	89	4.58	4.77	5.16	7.86
TR G 130 4 200		450	700	1300	3200	4000	7'	5'	30.0	5500	6500	89	4.61	4.81	5.19	7.90
TR G 130 4 210		450	700	1300	3200	4000	7'	5'	30.0	5500	6500	89	4.63	4.83	5.21	7.92
TR G 130 4 216		450	700	1300	2900	3500	7'	5'	30.0	5500	6500	89	4.31	4.50	4.89	7.59
TR G 130 4 250		450	700	1300	3200	4000	7'	5'	30.0	5500	6500	89	4.61	4.81	5.19	7.90
TR G 130 4 280		450	700	1300	3200	4000	7'	5'	30.0	5500	6500	89	4.60	4.80	5.18	7.89
TR G 130 4 350		450	700	1300	3200	4000	7'	5'	30.0	5500	6500	89	4.60	4.80	5.18	7.89
TR G 130 4 400		450	700	1300	3200	4000	7'	5'	30.0	5500	6500	89	4.60	4.80	5.18	7.89
TR G 130 4 500		450	700	1300	3200	4000	7'	5'	30.0	5500	6500	89	4.60	4.80	5.18	7.89
TR G 130 4 700		450	700	1300	3200	4000	7'	5'	30.0	5500	6500	89	4.60	4.80	5.18	7.89
TR G 130 4 1000		215	400	800	3200	4000	7'	5'	30.0	5500	6500	89	4.60	4.80	5.18	7.89

Please contact us for different motor adapters and input shaft bore.

TR MB 130

55A1 ... 180A1

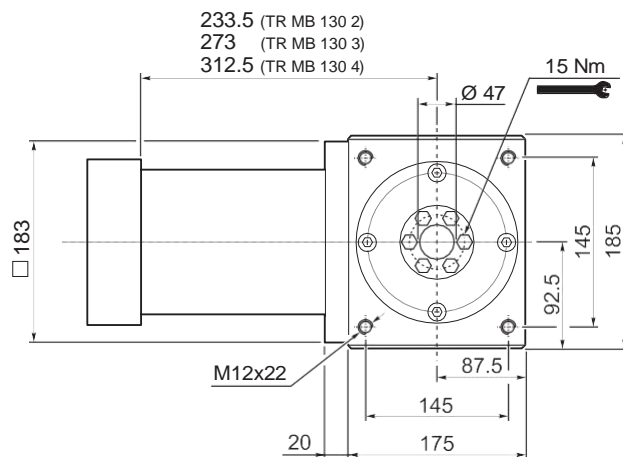
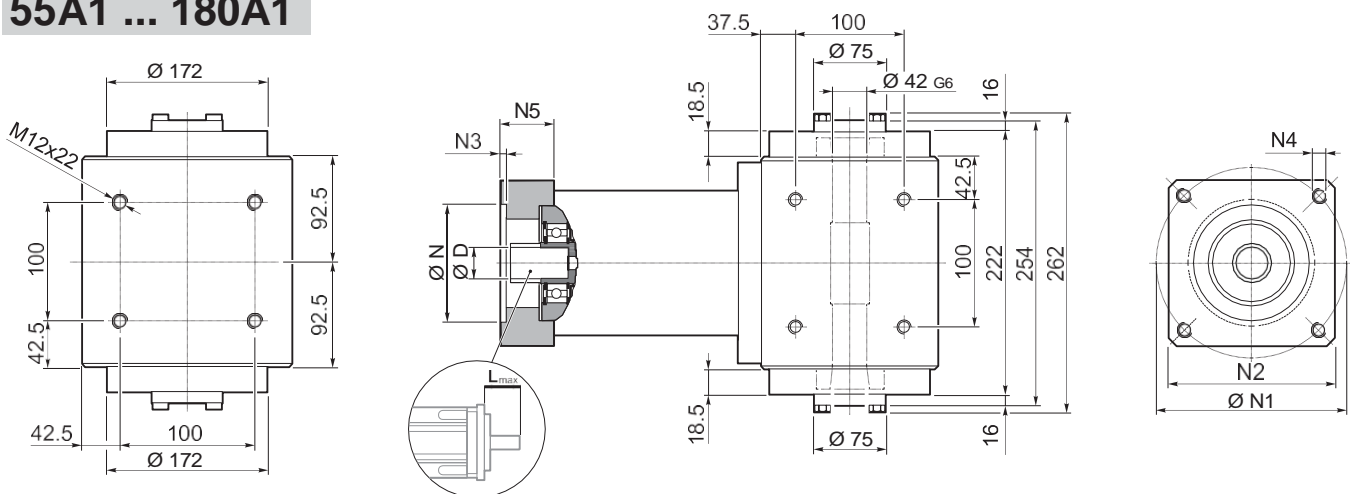

TR MB 130 2	54
TR MB 130 3	58
TR MB 130 4	61

											N	N1	N2	N3	N4	N5	L _{max}
	14	15.875	16	19	-	-	-	-	-	-							
55A1	14	15.875	16	19	-	-	-	-	-	-	55.5	125.7	130	4	M6x15	39.5	50
80A2	14	15.875	16	19	-	-	-	-	-	-	80	100	130	4	M6x15	39.5	50
95A1	14	15.875	16	19	22	24	-	-	-	-	95	115	130	4	M8x20	39.5	50
110A1	14	15.875	16	19	22	24	-	-	-	-	110	130	130	4	M8x20	39.5	50
110B1	14	15.875	16	19	22	24	-	-	-	-	110	145	130	6.5	M8x20	49.5	60
114A0	14	15.875	16	19	22	24	-	-	-	-	114.3	200	170	5.5	M12x25	39.5	50
114A	14	15.875	16	19	22	24	28	32	35	38	114.3	200	170	5.5	M12x25	69.5	80
130A	14	15.875	16	19	22	24	-	-	-	-	130	165	140	4	M10x20	39.5	50
130A1	14	15.875	16	19	22	24	28	32	-	-	130	165	140	4	M10x20	49.5	60
180A	14	15.875	16	19	22	24	28	32	-	-	180	215	190	5.5	M14x25	49.5	60
180A1	14	15.875	16	19	22	24	28	32	35	38	180	215	190	5.5	M14x25	69.5	80

TR MB 130

FM

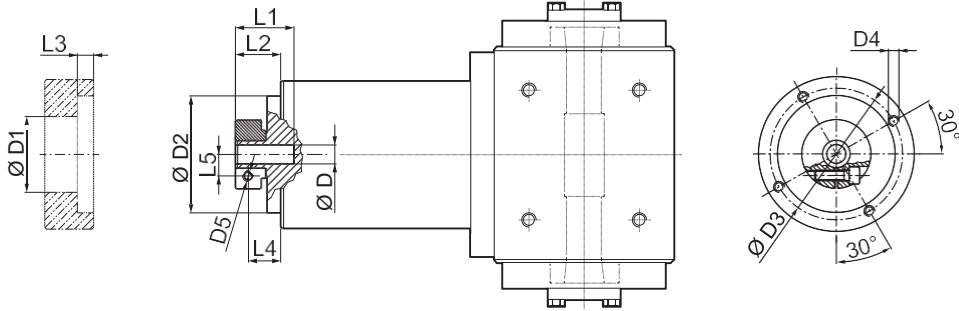

	D1	D2	D3	D4	D5	L1	L2	L3	L4	L5
14 15.875 16	48	113	125.5	M8x15	M6	40	27.5	6	20	14.5
19	51	113	125.5	M8x15	M6	40	27.5	6	20	16.5
22 24	56.5	113	125.5	M8x15	M6	41	28.5	6	19.5	19
28	67	113	125.5	M8x15	M8	41	28.5	6	19.5	22.5
32	71	113	125.5	M8x15	M8	41	28.5	6	19.5	24.5
35	73	113	125.5	M8x15	M8	50	37.5	11.25	26	26
38	77.5	113	125.5	M8x15	M8	50	37.5	11.25	26	28

TR

	M_{n2} [Nm]	M_{a2} [Nm]	M_{p2} [Nm]	n_1 [min ⁻¹]	n_{1max} [min ⁻¹]	ϕ_S [arcmin]	ϕ_R [arcmin]	C_t [Nm/arcmin]	η %	J_G [kgm ²]			
										14 ... 19	22 - 24	28 - 32	35 - 38
TR MB 130 2 3	215	400	800	2100	3000	5'	3'	45.0	94	5.25	5.46	5.81	7.16
TR MB 130 2 4	380	600	1100	2400	3500	5'	3'	45.0	94	3.06	3.26	3.61	4.97
TR MB 130 2 5	380	600	1100	2900	3500	5'	3'	45.0	94	2.22	2.42	2.77	4.13
TR MB 130 2 6	380	600	1100	2900	3500	5'	3'	45.0	94	1.19	1.40	1.75	3.10
TR MB 130 2 7	380	600	1100	3200	4000	5'	3'	45.0	94	1.47	1.68	2.03	3.38
TR MB 130 2 10	215	400	800	3200	4000	5'	3'	45.0	94	1.04	1.25	1.60	2.95
TR MB 130 3 9	215	400	800	2100	3000	5'	3'	38.5	91	4.82	5.02	5.37	6.72
TR MB 130 3 12	450	700	1300	2100	3000	5'	3'	38.5	91	4.57	4.78	5.13	6.48
TR MB 130 3 15	450	700	1300	2100	3000	5'	3'	38.5	91	4.48	4.69	5.04	6.39
TR MB 130 3 16	450	700	1300	2400	3500	5'	3'	38.5	91	2.67	2.88	3.23	4.58
TR MB 130 3 20	450	700	1300	2900	3500	5'	3'	38.5	91	1.97	2.18	2.53	3.88
TR MB 130 3 25	450	700	1300	2900	3500	5'	3'	38.5	91	1.94	2.15	2.50	3.85
TR MB 130 3 28	450	700	1300	3200	4000	5'	3'	38.5	91	1.34	1.55	1.90	3.25
TR MB 130 3 30	215	400	800	3200	4000	5'	3'	38.5	91	1.00	1.21	1.56	2.91
TR MB 130 3 35	450	700	1300	3200	4000	5'	3'	38.5	91	1.33	1.53	1.88	3.24
TR MB 130 3 36	380	600	1100	2900	3500	5'	3'	38.5	91	1.05	1.26	1.61	2.96
TR MB 130 3 40	450	700	1300	3200	4000	5'	3'	38.5	91	0.98	1.19	1.54	2.89
TR MB 130 3 50	450	700	1300	3200	4000	5'	3'	38.5	91	0.97	1.18	1.53	2.88
TR MB 130 3 70	450	700	1300	3200	4000	5'	3'	38.5	91	0.96	1.17	1.52	2.87
TR MB 130 3 100	215	400	800	3200	4000	5'	3'	38.5	91	0.96	1.17	1.52	2.87
TR MB 130 4 48	450	700	1300	2400	3500	7'	5'	30.0	89	2.77	2.98	3.33	4.68
TR MB 130 4 64	450	700	1300	2400	3500	7'	5'	30.0	89	2.65	2.86	3.21	4.56
TR MB 130 4 75	450	700	1300	2900	3500	7'	5'	30.0	89	2.03	2.24	2.59	3.94
TR MB 130 4 80	450	700	1300	2400	3500	7'	5'	30.0	89	2.65	2.85	3.20	4.56
TR MB 130 4 84	450	700	1300	3200	4000	7'	5'	30.0	89	1.37	1.58	1.93	3.28
TR MB 130 4 90	215	400	800	3200	4000	7'	5'	30.0	89	1.00	1.20	1.55	2.91
TR MB 130 4 120	450	700	1300	3200	4000	7'	5'	30.0	89	0.99	1.20	1.55	2.90
TR MB 130 4 125	450	700	1300	2900	3500	7'	5'	30.0	89	1.93	2.13	2.48	3.84
TR MB 130 4 140	450	700	1300	3200	4000	7'	5'	30.0	89	1.34	1.54	1.89	3.25
TR MB 130 4 150	450	700	1300	3200	4000	7'	5'	30.0	89	0.99	1.20	1.55	2.90
TR MB 130 4 160	450	700	1300	3200	4000	7'	5'	30.0	89	0.98	1.18	1.53	2.89
TR MB 130 4 175	450	700	1300	3200	4000	7'	5'	30.0	89	1.32	1.53	1.88	3.23
TR MB 130 4 200	450	700	1300	3200	4000	7'	5'	30.0	89	0.97	1.18	1.53	2.88
TR MB 130 4 210	450	700	1300	3200	4000	7'	5'	30.0	89	0.99	1.20	1.55	2.90
TR MB 130 4 216	450	700	1300	2900	3500	7'	5'	30.0	89	1.05	1.26	1.61	2.96
TR MB 130 4 250	450	700	1300	3200	4000	7'	5'	30.0	89	0.97	1.18	1.53	2.88
TR MB 130 4 280	450	700	1300	3200	4000	7'	5'	30.0	89	0.96	1.17	1.52	2.87
TR MB 130 4 350	450	700	1300	3200	4000	7'	5'	30.0	89	0.96	1.17	1.52	2.87
TR MB 130 4 400	450	700	1300	3200	4000	7'	5'	30.0	89	0.96	1.17	1.52	2.87
TR MB 130 4 500	450	700	1300	3200	4000	7'	5'	30.0	89	0.96	1.17	1.52	2.87
TR MB 130 4 700	450	700	1300	3200	4000	7'	5'	30.0	89	0.96	1.17	1.52	2.87
TR MB 130 4 1000	215	400	800	3200	4000	7'	5'	30.0	89	0.96	1.17	1.52	2.87

Please contact us for different motor adapters and input shaft bore.

TR 160

IS

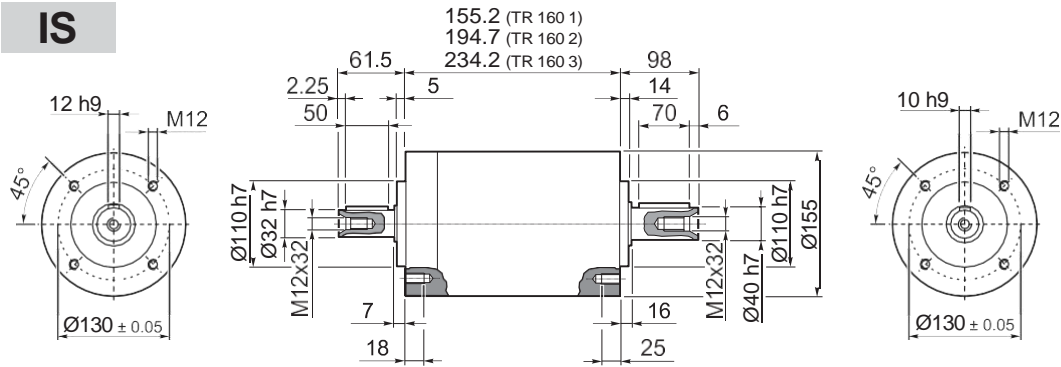

TR 160 1	17.0
TR 160 2	21
TR 160 3	28

TR

55A1 ... 180A1

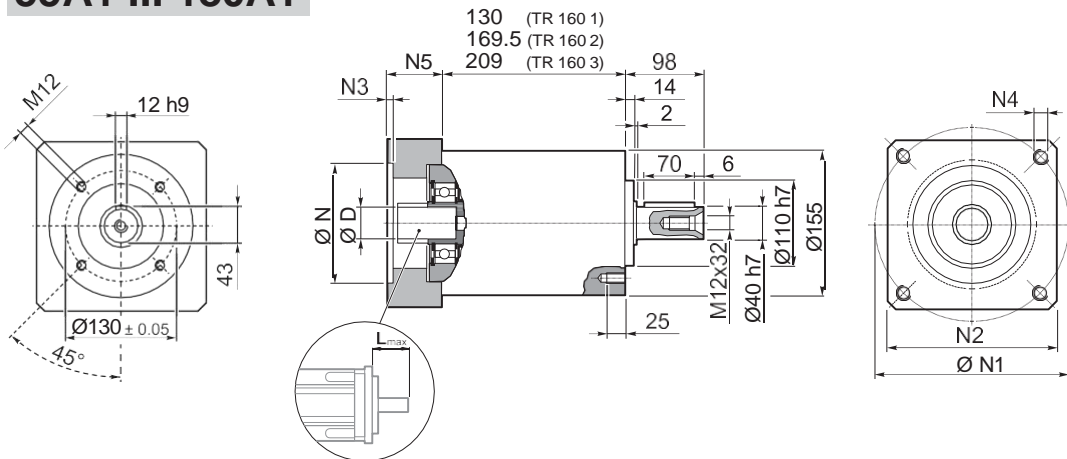

TR 160 1	17.0
TR 160 2	21
TR 160 3	28

											N	N1	N2	N3	N4	N5	L _{max}
55A1	14	15.875	16	19	-	-	-	-	-	-	55.5	125.7	140	5	M6x15	39.5	50
80A2	14	15.875	16	19	-	-	-	-	-	-	80	100	140	5	M6x15	39.5	50
95A1	14	15.875	16	19	22	24	-	-	-	-	95	115	140	5	M8x20	39.5	50
110A1	14	15.875	16	19	22	24	-	-	-	-	110	130	140	5	M8x20	39.5	50
110B1	14	15.875	16	19	22	24	-	-	-	-	110	145	140	6.5	M8x20	49.5	60
114A	14	15.875	16	19	22	24	28	32	35	38	114.3	200	170	6.5	M12x25	69.5	80
130A	14	15.875	16	19	22	24	-	-	-	-	130	165	140	5	M10x20	39.5	50
130A1	14	15.875	16	19	22	24	28	32	-	-	130	165	140	5	M10x20	49.5	60
180A	14	15.875	16	19	22	24	28	32	-	-	180	215	190	5.5	M14x25	49.5	60
180A1	14	15.875	16	19	22	24	28	32	35	38	180	215	190	5.5	M14x25	69.5	80

TR 160

FM

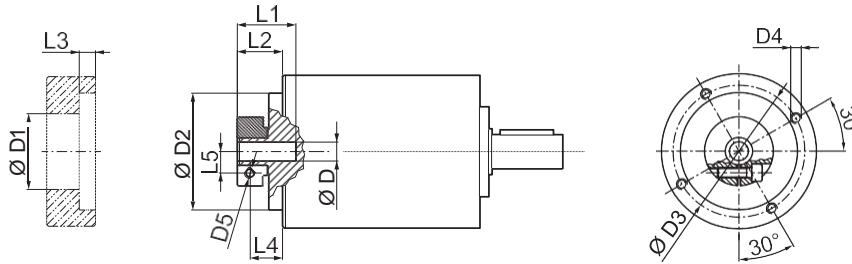

	D1	D2	D3	D4	D5	L1	L2	L3	L4	L5
14 15.875 16	48	130	142.5	M8x16	M6	40	27.5	6	20	14.5
19	51	130	142.5	M8x16	M6	40	27.5	6	20	16.5
22 24	56.5	130	142.5	M8x16	M6	41	28.5	6	19.5	19
28	67	130	142.5	M8x16	M8	41	28.5	6	19.5	22.5
32	71	130	142.5	M8x16	M8	41	28.5	6	19.5	24.5
35	73	130	142.5	M8x16	M8	50	37.5	11.25	26	26
38	77.5	130	142.5	M8x16	M8	50	37.5	11.25	26	28

	M _{n 2} [Nm]	M _{a 2} [Nm]	M _{p 2} [Nm]	n ₁ [min ⁻¹]	n _{1 max} [min ⁻¹]	φ _S [arcmin]	φ _R [arcmin]	C _t [Nm/arcmin]	R _{1 max} [N]	R _{2 max} [N]	A _{2 max} [N]	η %	J _G [kgcm ²]			
														14 ... 19	22 - 24	28 - 32
TR 160 1_3	350	660	1200	1900	3000	5'	3'	90	1200	6500	7500	97	8.39	8.60	8.95	10.30
TR 160 1_4	500	750	1400	2200	3500	5'	3'	90	1200	6500	7500	97	4.68	4.89	5.24	6.59
TR 160 1_5	500	750	1400	2500	3500	5'	3'	90	1200	6500	7500	97	3.28	3.49	3.84	5.19
TR 160 1_6	500	750	1400	2500	3500	5'	3'	90	1200	6500	7500	97	1.32	1.53	1.88	3.23
TR 160 1_7	500	750	1400	3000	4000	5'	3'	90	1200	6500	7500	97	2.03	2.24	2.59	3.94
TR 160 1_10	350	660	1200	3000	4000	5'	3'	90	1200	6500	7500	97	1.33	1.53	1.88	3.24
TR 160 2_9	350	660	1200	1900	3000	5'	3'	83.5	1200	6500	7500	94	7.51	7.72	8.07	9.42
TR 160 2_12	700	950	1800	1900	3000	5'	3'	83.5	1200	6500	7500	94	7.10	7.30	7.65	9.01
TR 160 2_15	700	950	1800	1900	3000	5'	3'	83.5	1200	6500	7500	94	6.94	7.15	7.50	8.85
TR 160 2_16	700	950	1800	2200	3500	5'	3'	83.5	1200	6500	7500	94	3.95	4.16	4.51	5.86
TR 160 2_20	700	950	1800	2500	3500	5'	3'	83.5	1200	6500	7500	94	2.82	3.02	3.37	4.73
TR 160 2_25	700	950	1800	2500	3500	5'	3'	83.5	1200	6500	7500	94	2.76	2.97	3.32	4.67
TR 160 2_28	700	950	1800	3000	4000	5'	3'	83.5	1200	6500	7500	94	1.79	2.00	2.35	3.70
TR 160 2_30	350	660	1200	3000	4000	5'	3'	83.5	1200	6500	7500	94	1.25	1.46	1.81	3.16
TR 160 2_35	700	950	1800	3000	4000	5'	3'	83.5	1200	6500	7500	94	1.77	1.97	2.32	3.68
TR 160 2_36	500	750	1400	2500	3500	5'	3'	83.5	1200	6500	7500	94	1.06	1.27	1.62	2.97
TR 160 2_40	700	950	1800	3000	4000	5'	3'	83.5	1200	6500	7500	94	1.21	1.42	1.77	3.12
TR 160 2_50	700	950	1800	3000	4000	5'	3'	83.5	1200	6500	7500	94	1.20	1.40	1.75	3.11
TR 160 2_70	700	950	1800	3000	4000	5'	3'	83.5	1200	6500	7500	94	1.18	1.39	1.74	3.09
TR 160 2_100	350	660	1200	3000	4000	5'	3'	83.5	1200	6500	7500	94	1.18	1.38	1.73	3.09
TR 160 3_48	700	950	1800	2200	3500	7'	5'	60	1200	6500	7500	91	4.10	4.31	4.66	6.01
TR 160 3_64	700	950	1800	2200	3500	7'	5'	60	1200	6500	7500	91	3.90	4.11	4.46	5.81
TR 160 3_75	700	950	1800	2500	3500	7'	5'	60	1200	6500	7500	91	2.91	3.11	3.46	4.82
TR 160 3_80	700	950	1800	2200	3500	7'	5'	60	1200	6500	7500	91	3.90	4.11	4.46	5.81
TR 160 3_84	700	950	1800	3000	4000	7'	5'	60	1200	6500	7500	91	1.84	2.05	2.40	3.75
TR 160 3_90	350	660	1200	3000	4000	7'	5'	60	1200	6500	7500	91	1.24	1.45	1.80	3.15
TR 160 3_120	700	950	1800	3000	4000	7'	5'	60	1200	6500	7500	91	1.23	1.44	1.79	3.14
TR 160 3_125	700	950	1800	2500	3500	7'	5'	60	1200	6500	7500	91	2.74	2.95	3.30	4.65
TR 160 3_140	700	950	1800	3000	4000	7'	5'	60	1200	6500	7500	91	1.78	1.98	2.33	3.69
TR 160 3_150	700	950	1800	3000	4000	7'	5'	60	1200	6500	7500	91	1.23	1.44	1.79	3.14
TR 160 3_160	700	950	1800	3000	4000	7'	5'	60	1200	6500	7500	91	1.20	1.41	1.76	3.11
TR 160 3_175	700	950	1800	3000	4000	7'	5'	60	1200	6500	7500	91	1.76	1.96	2.31	3.67
TR 160 3_200	700	950	1800	3000	4000	7'	5'	60	1200	6500	7500	91	1.20	1.41	1.76	3.11
TR 160 3_210	700	950	1800	3000	4000	7'	5'	60	1200	6500	7500	91	1.23	1.44	1.79	3.14
TR 160 3_250	700	950	1800	3000	4000	7'	5'	60	1200	6500	7500	91	1.19	1.40	1.75	3.10
TR 160 3_280	700	950	1800	3000	4000	7'	5'	60	1200	6500	7500	91	1.18	1.39	1.74	3.09
TR 160 3_350	700	950	1800	3000	4000	7'	5'	60	1200	6500	7500	91	1.18	1.39	1.74	3.09
TR 160 3_400	700	950	1800	3000	4000	7'	5'	60	1200	6500	7500	91	1.18	1.38	1.73	3.09
TR 160 3_500	700	950	1800	3000	4000	7'	5'	60	1200	6500	7500	91	1.18	1.38	1.73	3.09
TR 160 3_700	700	950	1800	3000	4000	7'	5'	60	1200	6500	7500	91	1.18	1.38	1.73	3.09
TR 160 3_1000	350	660	1200	3000	4000	7'	5'	60	1200	6500	7500	91	1.18	1.38	1.73	3.09

Please contact us for different motor adapters and input shaft bore.

TR G 160

55A1 ... 180A1

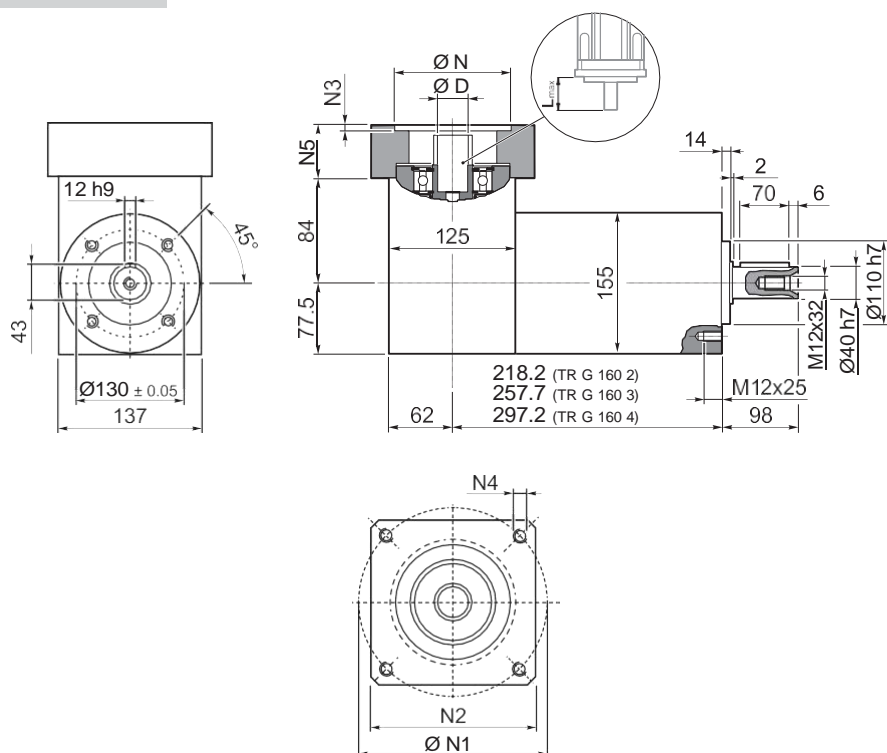

TR

											N	N1	N2	N3	N4	N5	L _{max}
	D																
55A1	14	15.875	16	19	-	-	-	-	-	-	55.5	125.7	140	5	M6x15	39.5	50
80A2	14	15.875	16	19	-	-	-	-	-	-	80	100	140	5	M6x15	39.5	50
95A1	14	15.875	16	19	22	24	-	-	-	-	95	115	140	5	M8x20	39.5	50
110A1	14	15.875	16	19	22	24	-	-	-	-	110	130	140	5	M8x20	39.5	50
110B1	14	15.875	16	19	22	24	-	-	-	-	110	145	140	6.5	M8x20	49.5	60
114A	14	15.875	16	19	22	24	28	32	35	38	114.3	200	170	6.5	M12x25	69.5	80
130A	14	15.875	16	19	22	24	-	-	-	-	130	165	140	5	M10x20	39.5	50
130A1	14	15.875	16	19	22	24	28	32	-	-	130	165	140	5	M10x20	49.5	60
180A	14	15.875	16	19	22	24	28	32	-	-	180	215	190	5.5	M14x25	49.5	60
180A1	14	15.875	16	19	22	24	28	32	35	38	180	215	190	5.5	M14x25	69.5	80

TR G 160

FM

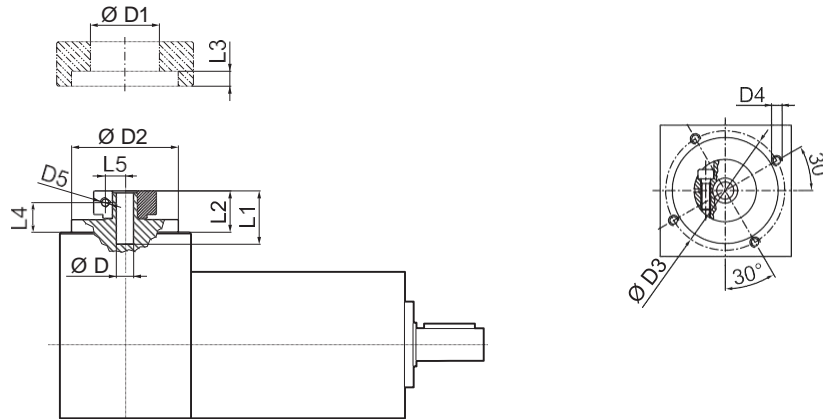

D			D1	D2	D3	D4	D5	L1	L2	L3	L4	L5
14	15.875	16	48	113	125.5	M8x15	M6	40	27.5	6	20	14.5
19			51	113	125.5	M8x15	M6	40	27.5	6	20	16.5
22	24		56.5	113	125.5	M8x15	M6	41	28.5	6	19.5	19
28			67	113	125.5	M8x15	M8	41	28.5	6	19.5	22.5
32			71	113	125.5	M8x15	M8	41	28.5	6	19.5	24.5
35			73	113	125.5	M8x15	M8	50	37.5	11.25	26	26
38			77.5	113	125.5	M8x15	M8	50	37.5	11.25	26	28

TR

i	M _{n2} [Nm]	M _{a2} [Nm]	M _{p2} [Nm]	n ₁ [min ⁻¹]	n _{1 max} [min ⁻¹]	φ _S [arcmin]	φ _R [arcmin]	C _t [Nm/arcmin]	R _{2 max} [N]	A _{2 max} [N]	η %	J _G [kgcm ²]			
												14 ... 19	22 - 24	28 - 32	35 - 38
TR G 160 2 3	350	660	1200	1900	3000	5'	3'	90	6500	7500	94	10.23	10.42	10.80	13.51
TR G 160 2 4	500	750	1400	2200	3500	5'	3'	90	6500	7500	94	6.52	6.71	7.09	9.80
TR G 160 2 5	500	750	1400	2500	3500	5'	3'	90	6500	7500	94	5.87	6.06	6.45	9.16
TR G 160 2 6	500	750	1400	2500	3500	5'	3'	90	6500	7500	94	4.58	4.77	5.16	7.86
TR G 160 2 7	500	750	1400	3000	4000	5'	3'	90	6500	7500	94	5.29	5.48	5.87	8.57
TR G 160 2 10	350	660	1200	3000	4000	5'	3'	90	6500	7500	94	4.97	5.16	5.54	8.25
TR G 160 3 9	350	660	1200	1900	3000	5'	3'	83.5	6500	7500	91	9.35	9.54	9.92	12.63
TR G 160 3 12	700	950	1800	1900	3000	5'	3'	83.5	6500	7500	91	8.78	8.97	9.36	12.07
TR G 160 3 15	700	950	1800	1900	3000	5'	3'	83.5	6500	7500	91	8.71	8.90	9.29	11.99
TR G 160 3 16	700	950	1800	2200	3500	5'	3'	83.5	6500	7500	91	5.79	5.98	6.36	9.07
TR G 160 3 20	700	950	1800	2500	3500	5'	3'	83.5	6500	7500	91	5.41	6.20	6.59	9.30
TR G 160 3 25	700	950	1800	2500	3500	5'	3'	83.5	6500	7500	91	5.95	5.54	5.93	8.64
TR G 160 3 28	700	950	1800	3000	4000	5'	3'	83.5	6500	7500	91	5.05	5.24	5.63	8.33
TR G 160 3 30	350	660	1200	3000	4000	5'	3'	83.5	6500	7500	91	4.89	5.09	5.47	8.18
TR G 160 3 35	700	950	1800	3000	4000	5'	3'	83.5	6500	7500	91	5.36	5.54	5.93	8.64
TR G 160 3 36	500	750	1400	2500	3500	5'	3'	83.5	6500	7500	91	4.32	4.51	4.90	7.60
TR G 160 3 40	700	950	1800	3000	4000	5'	3'	83.5	6500	7500	91	5.00	5.19	5.58	8.28
TR G 160 3 50	700	950	1800	3000	4000	5'	3'	83.5	6500	7500	91	4.99	5.18	5.56	8.27
TR G 160 3 70	700	950	1800	3000	4000	5'	3'	83.5	6500	7500	91	4.82	5.02	5.40	8.11
TR G 160 3 100	350	660	1200	3000	4000	5'	3'	83.5	6500	7500	91	4.82	5.01	5.39	8.10
TR G 160 4 48	700	950	1800	2200	3500	7'	5'	60	6500	7500	89	5.94	6.13	6.53	9.22
TR G 160 4 64	700	950	1800	2200	3500	7'	5'	60	6500	7500	89	5.74	5.93	6.31	9.02
TR G 160 4 75	700	950	1800	2500	3500	7'	5'	60	6500	7500	89	5.50	5.68	6.07	8.79
TR G 160 4 80	700	950	1800	2200	3500	7'	5'	60	6500	7500	89	5.74	5.93	6.31	9.02
TR G 160 4 84	700	950	1800	3000	4000	7'	5'	60	6500	7500	89	5.10	5.29	5.68	8.38
TR G 160 4 90	350	660	1200	3000	4000	7'	5'	60	6500	7500	89	4.88	5.08	5.46	8.17
TR G 160 4 120	700	950	1800	3000	4000	7'	5'	60	6500	7500	89	4.87	5.07	5.45	8.16
TR G 160 4 125	700	950	1800	2500	3500	7'	5'	60	6500	7500	89	5.33	5.52	5.91	8.62
TR G 160 4 140	700	950	1800	3000	4000	7'	5'	60	6500	7500	89	5.04	5.22	5.61	8.32
TR G 160 4 150	700	950	1800	3000	4000	7'	5'	60	6500	7500	89	4.87	5.07	5.45	8.16
TR G 160 4 160	700	950	1800	3000	4000	7'	5'	60	6500	7500	89	4.84	5.04	5.42	8.13
TR G 160 4 175	700	950	1800	3000	4000	7'	5'	60	6500	7500	89	5.02	5.20	5.59	8.30
TR G 160 4 200	700	950	1800	3000	4000	7'	5'	60	6500	7500	89	4.84	5.04	5.42	8.13
TR G 160 4 210	700	950	1800	3000	4000	7'	5'	60	6500	7500	89	4.87	5.07	5.45	8.16
TR G 160 4 250	700	950	1800	3000	4000	7'	5'	60	6500	7500	89	4.83	5.03	5.41	8.12
TR G 160 4 280	700	950	1800	3000	4000	7'	5'	60	6500	7500	89	4.82	5.02	5.40	8.11
TR G 160 4 350	700	950	1800	3000	4000	7'	5'	60	6500	7500	89	4.82	2.05	5.40	8.11
TR G 160 4 400	700	950	1800	3000	4000	7'	5'	60	6500	7500	89	4.82	5.01	5.39	8.11
TR G 160 4 500	700	950	1800	3000	4000	7'	5'	60	6500	7500	89	4.82	5.01	5.39	8.11
TR G 160 4 700	700	950	1800	3000	4000	7'	5'	60	6500	7500	89	4.82	5.01	5.39	8.11
TR G 160 4 1000	350	660	1200	3000	4000	7'	5'	60	6500	7500	89	4.82	5.01	5.39	8.11

Please contact us for different motor adapters and input shaft bore.

TR MB 160

55A1 ... 180A1

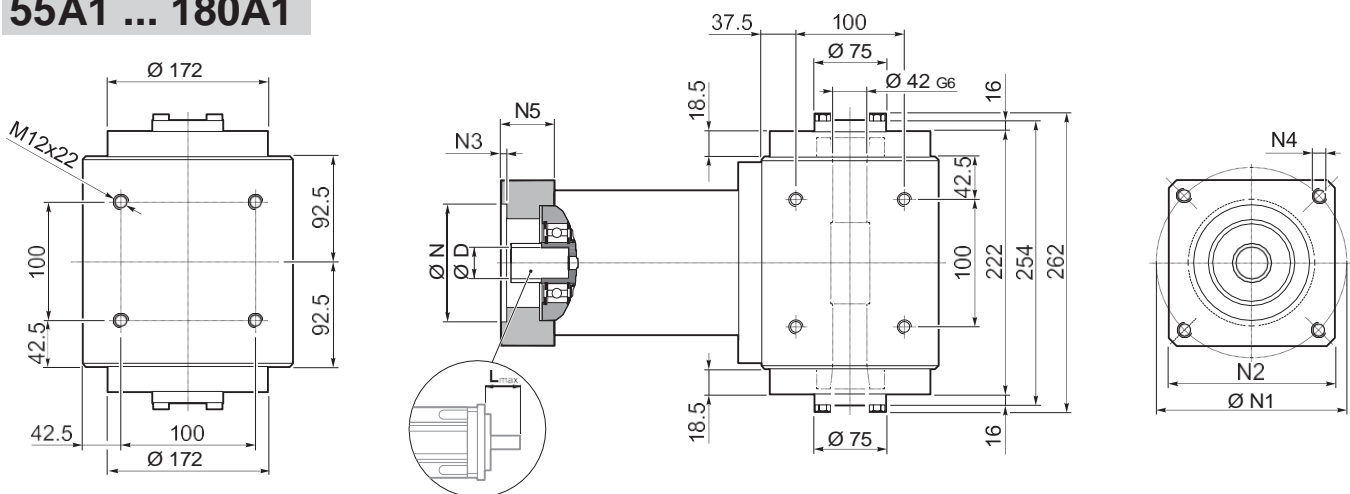

TR

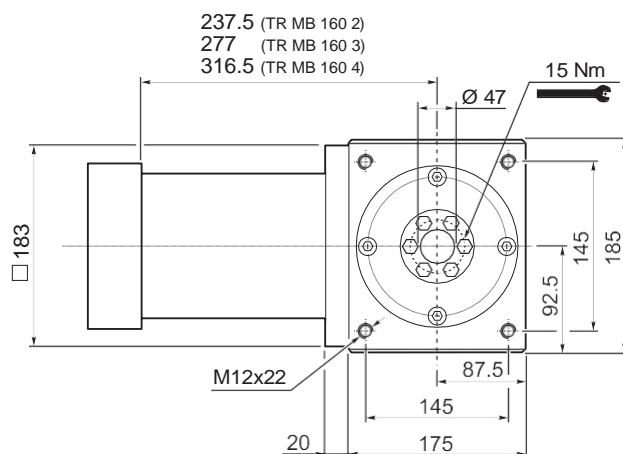

237.5 (TR MB 160 2)
277 (TR MB 160 3)
316.5 (TR MB 160 4)

TR MB 160 2	59
TR MB 160 3	63.5
TR MB 160 4	70.5

											N	N1	N2	N3	N4	N5	L _{max}
	D																
55A1	14	15.875	16	19	-	-	-	-	-	-	55.5	125.7	140	5	M6x15	39.5	50
80A2	14	15.875	16	19	-	-	-	-	-	-	80	100	140	5	M6x15	39.5	50
95A1	14	15.875	16	19	22	24	-	-	-	-	95	115	140	5	M8x20	39.5	50
110A1	14	15.875	16	19	22	24	-	-	-	-	110	130	140	5	M8x20	39.5	50
110B1	14	15.875	16	19	22	24	-	-	-	-	110	145	140	6.5	M8x20	49.5	60
114A	14	15.875	16	19	22	24	28	32	35	38	114.3	200	170	6.5	M12x25	69.5	80
130A	14	15.875	16	19	22	24	-	-	-	-	130	165	140	5	M10x20	39.5	50
130A1	14	15.875	16	19	22	24	28	32	-	-	130	165	140	5	M10x20	49.5	60
180A	14	15.875	16	19	22	24	28	32	-	-	180	215	190	5.5	M14x25	49.5	60
180A1	14	15.875	16	19	22	24	28	32	35	38	180	215	190	5.5	M14x25	69.5	80

TR MB 160

FM

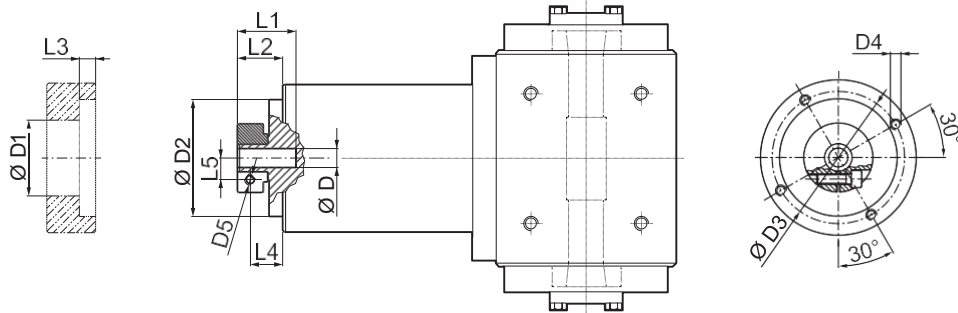

	D1	D2	D3	D4	D5	L1	L2	L3	L4	L5
14 15.875 16	48	130	142.5	M8x16	M6	40	27.5	6	20	14.5
19	51	130	142.5	M8x16	M6	40	27.5	6	20	16.5
22 24	56.5	130	142.5	M8x16	M6	41	28.5	6	19.5	19
28	67	130	142.5	M8x16	M8	41	28.5	6	19.5	22.5
32	71	130	142.5	M8x16	M8	41	28.5	6	19.5	24.5
35	73	130	142.5	M8x16	M8	50	37.5	11.25	26	26
38	77.5	130	142.5	M8x16	M8	50	37.5	11.25	26	28

TR

	M_{N2} [Nm]	M_{A2} [Nm]	M_{P2} [Nm]	n_1 [min ⁻¹]	n_{1max} [min ⁻¹]	ϕ_S	ϕ_R	C_t [Nm/arcmin]	η %	J_G [kgm ²]			
											14 ... 19	22 - 24	28 - 32
TR MB 160 2 3	350	660	1200	1900	3000	5'	3'	90	94	8.39	8.60	8.95	10.30
TR MB 160 2 4	500	750	1400	2200	3500	5'	3'	90	94	4.68	4.89	5.24	6.59
TR MB 160 2 5	500	750	1400	2500	3500	5'	3'	90	94	3.28	3.49	3.84	5.19
TR MB 160 2 6	500	750	1400	2500	3500	5'	3'	90	94	1.32	1.53	1.88	3.23
TR MB 160 2 7	500	750	1400	3000	4000	5'	3'	90	94	2.03	2.24	2.59	3.94
TR MB 160 2 10	350	660	1200	3000	4000	5'	3'	90	94	1.33	1.53	1.88	3.24
TR MB 160 3 9	350	660	1200	1900	3000	5'	3'	83	91	7.51	7.72	8.07	9.42
TR MB 160 3 12	700	950	1800	1900	3000	5'	3'	83	91	7.10	7.30	7.65	9.01
TR MB 160 3 15	700	950	1800	1900	3000	5'	3'	83	91	6.94	7.15	7.50	8.85
TR MB 160 3 16	700	950	1800	2200	3500	5'	3'	83	91	3.95	4.16	4.51	5.86
TR MB 160 3 20	700	950	1800	2500	3500	5'	3'	83	91	2.82	3.02	3.37	4.73
TR MB 160 3 25	700	950	1800	2500	3500	5'	3'	83	91	2.76	2.97	3.32	4.67
TR MB 160 3 28	700	950	1800	3000	4000	5'	3'	83	91	1.79	2.00	2.35	3.70
TR MB 160 3 30	350	660	1200	3000	4000	5'	3'	83	91	1.25	1.46	1.81	3.16
TR MB 160 3 35	700	950	1800	3000	4000	5'	3'	83	91	1.77	1.97	2.32	3.68
TR MB 160 3 36	500	750	1400	2500	3500	5'	3'	83	91	1.06	1.27	1.62	2.97
TR MB 160 3 40	700	950	1800	3000	4000	5'	3'	83	91	1.21	1.42	1.77	3.12
TR MB 160 3 50	700	950	1800	3000	4000	5'	3'	83	91	1.20	1.40	1.75	3.11
TR MB 160 3 70	700	950	1800	3000	4000	5'	3'	83	91	1.18	1.39	1.74	3.09
TR MB 160 3 100	350	660	1200	3000	4000	5'	3'	83	91	1.18	1.38	1.73	3.09
TR MB 160 4 48	700	950	1800	2200	3500	7'	5'	60	89	4.10	4.31	4.66	6.01
TR MB 160 4 64	700	950	1800	2200	3500	7'	5'	60	89	3.90	4.11	4.46	5.81
TR MB 160 4 75	700	950	1800	2500	3500	7'	5'	60	89	2.91	3.11	3.46	4.82
TR MB 160 4 80	700	950	1800	2200	3500	7'	5'	60	89	3.90	4.11	4.46	5.81
TR MB 160 4 84	700	950	1800	3000	4000	7'	5'	60	89	1.84	2.05	2.40	3.75
TR MB 160 4 90	350	660	1200	3000	4000	7'	5'	60	89	1.24	1.45	1.80	3.15
TR MB 160 4 120	700	950	1800	3000	4000	7'	5'	60	89	1.23	1.44	1.79	3.14
TR MB 160 4 125	700	950	1800	2500	3500	7'	5'	60	89	2.74	2.95	3.30	4.65
TR MB 160 4 140	700	950	1800	3000	4000	7'	5'	60	89	1.78	1.98	2.33	3.69
TR MB 160 4 150	700	950	1800	3000	4000	7'	5'	60	89	1.23	1.44	1.79	3.14
TR MB 160 4 160	700	950	1800	3000	4000	7'	5'	60	89	1.20	1.41	1.76	3.11
TR MB 160 4 175	700	950	1800	3000	4000	7'	5'	60	89	1.76	1.96	2.31	3.67
TR MB 160 4 200	700	950	1800	3000	4000	7'	5'	60	89	1.20	1.41	1.76	3.11
TR MB 160 4 210	700	950	1800	3000	4000	7'	5'	60	89	1.23	1.44	1.79	3.14
TR MB 160 4 250	700	950	1800	3000	4000	7'	5'	60	89	1.19	1.40	1.75	3.10
TR MB 160 4 280	700	950	1800	3000	4000	7'	5'	60	89	1.18	1.39	1.74	3.09
TR MB 160 4 350	700	950	1800	3000	4000	7'	5'	60	89	1.18	1.39	1.74	3.09
TR MB 160 4 400	700	950	1800	3000	4000	7'	5'	60	89	1.18	1.38	1.73	3.09
TR MB 160 4 500	700	950	1800	3000	4000	7'	5'	60	89	1.18	1.38	1.73	3.09
TR MB 160 4 700	700	950	1800	3000	4000	7'	5'	60	89	1.18	1.38	1.73	3.09
TR MB 160 4 1000	350	660	1200	3000	4000	7'	5'	60	89	1.18	1.38	1.73	3.09

Please contact us for different motor adapters and input shaft bore.

TR 190

55A1 ... 180A1

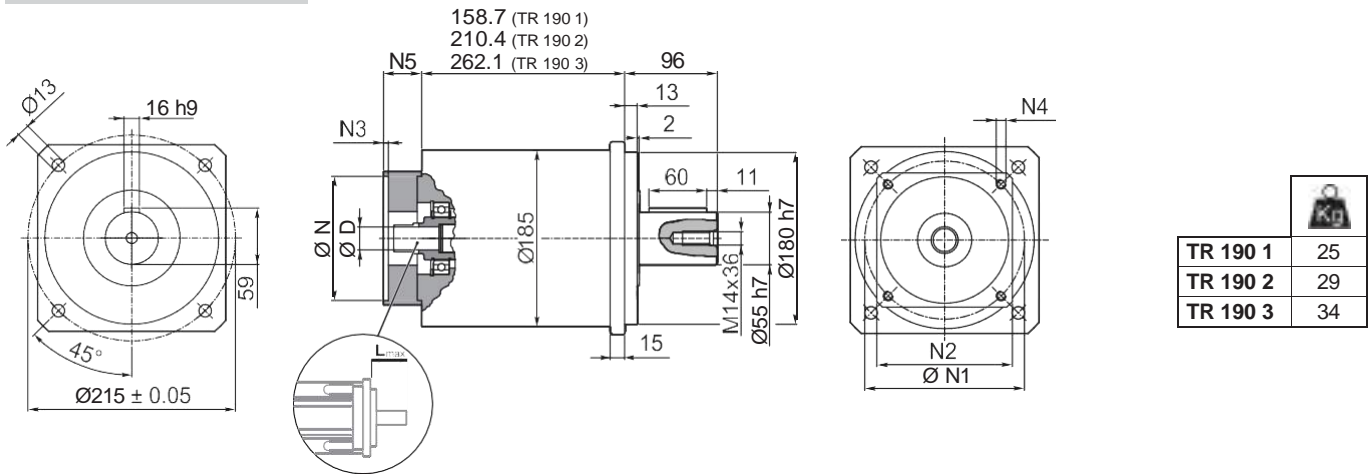

TR

	D												N	N1	N2	N3	N4	N5	L _{max}	
55A1	14	16	19	-	-	-	-	-	-	-	-	-	-	55.5	125.7	140	5	M6x15	39.5	50
80A2	14	16	19	-	-	-	-	-	-	-	-	-	-	80	100	140	5	M6x15	39.5	50
95A1	14	16	19	22	24	-	-	-	-	-	-	-	-	95	115	140	5	M8x20	39.5	50
110A1	14	16	19	22	24	-	-	-	-	-	-	-	-	110	130	140	5	M8x20	39.5	50
110B1	14	16	19	22	24	-	-	-	-	-	-	-	-	110	145	140	6.5	M8x20	49.5	60
114A	14	16	19	22	24	28	32	35	38	42	45	48	114.3	200	170	6.5	M12x25	69.5	80	
130A	14	16	19	22	24	-	-	-	-	-	-	-	130	165	140	5	M10x20	39.5	50	
130A1	14	16	19	22	24	28	32	-	-	-	-	-	130	165	140	5	M10x20	49.5	60	
180A	14	16	19	22	24	28	32	-	-	-	-	-	180	215	190	5.5	M14x25	49.5	60	
180A1	14	16	19	22	24	28	32	35	38	42	45	48	180	215	190	5.5	M14x25	69.5	80	

Please contact us for different motor adapters and input shaft bore.

FM

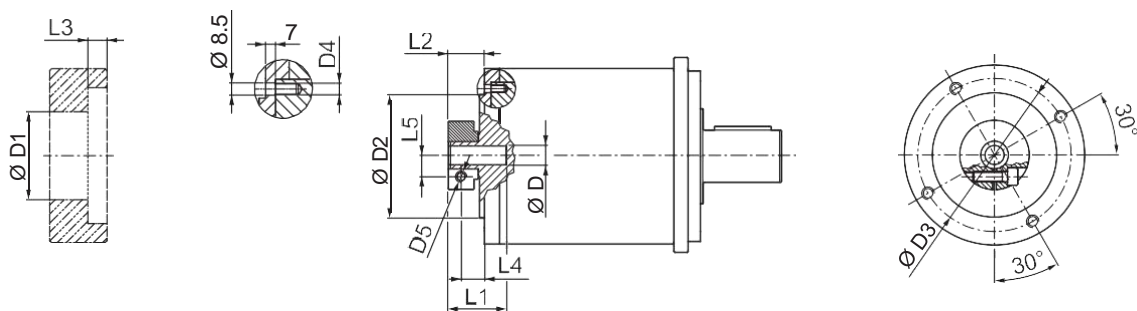

D	D1	D2	D3	D4	D5	L1	L2	L3	L4	L5
14 16	48	130	142.5	M8x14	M6	45.5	27.5	6	20	14.5
19	51	130	142.5	M8x14	M6	45.5	27.5	6	20	16.5
22 24	56.5	130	142.5	M8x14	M6	47	29	6	20	19
28	67	130	142.5	M8x14	M8	47	29	6	20	22.5
32	71	130	142.5	M8x14	M8	47	29	6	20	24.5
35	73	130	142.5	M8x14	M8	54.5	36.5	6	25	26
38	77.5	130	142.5	M8x14	M8	54.5	36.5	6	25	28
42	92	130	142.5	M8x14	M10	60.5	40	6	25	33
45	95	130	142.5	M8x14	M10	60.5	40	6	25	33
48	97	130	142.5	M8x14	M10	60.5	40	6	25	33

TR 190

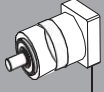
 i	M _{n 2}	M _{a 2}	M _{p 2}	n ₁	n _{1 max}	φ _S	φ _R	C _t	R _{2 max}	A _{2 max}	η	J _G [kgcm ²]				
	[Nm]	[Nm]	[Nm]	[min ⁻¹]	[min ⁻¹]	[arcmin]	[arcmin]	$\left[\frac{Nm}{arcmin} \right]$	[N]	[N]	%	14 ... 24	28 - 32	35 - 35	42	45 - 48
TR 190 1_3	500	800	1400	1500	2500	5'	3'	130	14000	15000	97	24.20	24.88	25.65	29.30	29.90
TR 190 1_4	700	950	1800	2100	3000	5'	3'	130	14000	15000	97	13.41	14.09	14.85	18.51	19.11
TR 190 1_5	700	950	1800	2300	3000	5'	3'	130	14000	15000	97	9.32	10.00	10.77	14.42	15.02
TR 190 1_6	700	950	1800	2300	3000	5'	3'	130	14000	15000	97	2.88	3.56	4.33	7.98	8.58
TR 190 1_7	700	950	1800	2900	3500	5'	3'	130	14000	15000	97	5.68	6.36	7.13	10.78	11.38
TR 190 1_10	500	800	1400	2900	3500	5'	3'	130	14000	15000	97	3.57	4.25	5.02	8.67	9.27
TR 190 2_9	500	800	1400	1500	2500	5'	3'	100	14000	15000	94	23.23	23.91	24.67	28.33	28.93
TR 190 2_12	1000	1200	2200	1500	2500	5'	3'	100	14000	15000	94	22.03	22.71	23.48	27.13	27.73
TR 190 2_15	1000	1200	2200	1500	2500	5'	3'	100	14000	15000	94	21.58	22.25	23.02	26.68	27.27
TR 190 2_16	1000	1200	2200	2100	3000	5'	3'	100	14000	15000	94	12.19	12.86	13.63	17.29	17.89
TR 190 2_20	1000	1200	2200	2300	3000	5'	3'	100	14000	15000	94	8.54	9.22	9.98	13.64	14.24
TR 190 2_25	1000	1200	2200	2300	3000	5'	3'	100	14000	15000	94	8.37	9.05	9.82	13.48	14.07
TR 190 2_28	1000	1200	2200	2900	3500	5'	3'	100	14000	15000	94	5.28	5.96	6.73	10.38	10.98
TR 190 2_30	500	800	1400	2900	3500	5'	3'	100	14000	15000	94	3.48	4.16	4.93	8.58	9.18
TR 190 2_35	1000	1200	2200	2900	3500	5'	3'	100	14000	15000	94	5.20	5.87	6.64	10.30	10.90
TR 190 2_36	700	950	1800	2300	3000	5'	3'	100	14000	15000	94	2.18	2.86	3.63	7.28	7.88
TR 190 2_40	1000	1200	2200	2900	3500	5'	3'	100	14000	15000	94	3.37	4.05	4.82	8.48	9.07
TR 190 2_50	1000	1200	2200	2900	3500	5'	3'	100	14000	15000	94	3.33	4.01	4.78	8.44	9.03
TR 190 2_70	1000	1200	2200	2900	3500	5'	3'	100	14000	15000	94	3.30	3.97	4.74	8.40	9.00
TR 190 2_100	500	800	1400	2900	3500	5'	3'	100	14000	15000	94	3.28	3.95	4.72	8.38	8.98
TR 190 3_48	1000	1200	2200	2100	3000	7'	5'	90	14000	15000	91	12.73	13.40	14.17	17.83	18.43
TR 190 3_64	1000	1200	2200	2100	3000	7'	5'	90	14000	15000	91	12.10	12.78	13.55	17.21	17.80
TR 190 3_75	1000	1200	2200	2300	3000	7'	5'	90	14000	15000	91	8.86	9.54	10.31	13.97	14.56
TR 190 3_80	1000	1200	2200	2100	3000	7'	5'	90	14000	15000	91	12.09	12.76	13.53	17.19	17.79
TR 190 3_84	1000	1200	2200	2900	3500	7'	5'	90	14000	15000	91	5.46	6.13	6.90	10.56	11.16
TR 190 3_90	500	800	1400	2900	3500	7'	5'	90	14000	15000	91	3.47	4.15	4.92	8.57	9.17
TR 190 3_120	1000	1200	2200	2900	3500	7'	5'	90	14000	15000	91	3.46	4.14	4.91	8.56	9.16
TR 190 3_125	1000	1200	2200	2300	3000	7'	5'	90	14000	15000	91	8.34	9.01	9.78	13.44	14.04
TR 190 3_140	1000	1200	2200	2900	3500	7'	5'	90	14000	15000	91	5.25	5.92	6.69	10.35	10.95
TR 190 3_150	1000	1200	2200	2900	3500	7'	5'	90	14000	15000	91	3.46	4.13	4.90	8.56	9.15
TR 190 3_160	1000	1200	2200	2900	3500	7'	5'	90	14000	15000	91	3.36	4.04	4.81	8.46	9.06
TR 190 3_175	1000	1200	2200	2900	3500	7'	5'	90	14000	15000	91	5.18	5.85	6.62	10.28	10.88
TR 190 3_200	1000	1200	2200	2900	3500	7'	5'	90	14000	15000	91	3.36	4.03	4.80	8.46	9.06
TR 190 3_210	1000	1200	2200	2900	3500	7'	5'	90	14000	15000	91	3.45	4.13	4.90	8.55	9.15
TR 190 3_250	1000	1200	2200	2900	3500	7'	5'	90	14000	15000	91	3.32	4.00	4.77	8.42	9.02
TR 190 3_280	1000	1200	2200	2900	3500	7'	5'	90	14000	15000	91	3.29	3.97	4.74	8.39	8.99
TR 190 3_350	1000	1200	2200	2900	3500	7'	5'	90	14000	15000	91	3.29	3.97	4.74	8.39	8.99
TR 190 3_400	1000	1200	2200	2900	3500	7'	5'	90	14000	15000	91	3.27	3.95	4.72	8.38	8.97
TR 190 3_500	1000	1200	2200	2900	3500	7'	5'	90	14000	15000	91	3.27	3.95	4.72	8.38	8.97
TR 190 3_700	1000	1200	2200	2900	3500	7'	5'	90	14000	15000	91	3.27	3.95	4.72	8.38	8.97
TR 190 3_1000	500	800	1400	2900	3500	7'	5'	90	14000	15000	91	3.27	3.95	4.72	8.38	8.97

5.3.1 MACHINE SHAFT

Shaft of driven equipment should be made from high grade alloy steel. Table below shows recommended dimensions for the Customer to consider when designing mating shaft. A device retaining the shaft axially is also recommended (not shown). The number and size of relative tapped holes at shaft end depend on application requirements.

MB

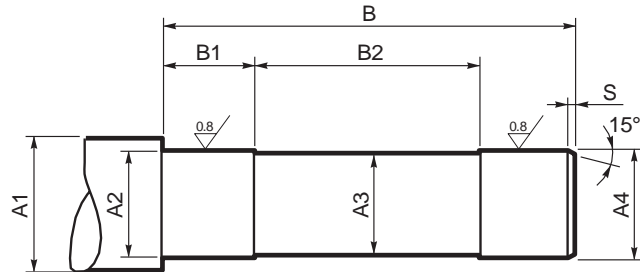

TR

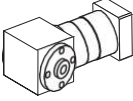
	A1	A2	A3	A4	B	B1	B2	S
TR MB 080	≥ 25	20 h7	18	20 h7	178	50	90	1
TR MB 105	≥ 40	32 h7	30	32 h7	205	60	115	
TR MB 130/160	≥ 50	42 h7	40	42 h7	259	70	140	



MP Series

The MP series is characterized by a wide range of torque and multiple sizes, great modularity due to multiple design configurations a wide ratios range and different optimized lubrications ensuring high reliability and the most fitting response to different applications requirements.

Other design versions

- K/G version



- MB version



Main benefits

- Wide torque range
- High overload capacity
- Great flexibility thanks to a wide range of gear ratios and multiple design configurations

Main features

- Nominal output torque (Nm)

12 - 1000

- Torsional backlash (arcmin)

10 - 17

- Torsional stiffness (Nm/arcmin)

0.7 - 130

- Max tilting moment (Nm)

16 - 1683

Protection class

- IP65

Frame sizes

- 053
- 060
- 080
- 105
- 130
- 160
- 190

Main options

- Design versions

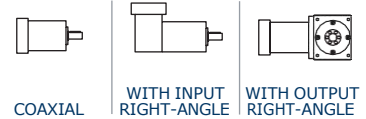

- Input versions

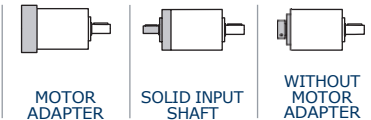

- Output shafts versions

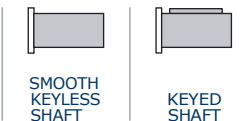

- Service type



- Lubrication



- Bearings versions



6 FEATURES OF MP SERIES

Planetary gear units of the MP series belong to a range of low backlash drives very broad and complete as far as transmissible torque, gear ratios and torsional backlash.

All units are generously proportioned to run quietly and provide a long service life without maintenance requirements.

Motor mounting is an operation that can be easily conducted without the need of any particular tooling, other than that usually available in a normally equipped workshop.

- Available with either standard (STD) or reduced (LOW) backlash:
 - 1-stage units: standard $\phi_s \leq 15'$; reduced $\phi_R \leq 10'$
 - 2-stage units: standard $\phi_s \leq 15'$; reduced $\phi_R \leq 10'$
 - 3-stage units (G and MB only): standard $\phi_R \leq 15'$; reduced $\phi_R \leq 10'$
 - 3-stage units: standard $\phi_s \leq 17'$; reduced $\phi_R \leq 12'$
 - 4-stage units (G and MB only): standard $\phi_s \leq 17'$; reduced $\phi_R \leq 12'$
- A high IP rating (IP65) provides inner parts with protection against the ingress of dust and liquids.
- Fluoroelastometer oils seals are supplied for S1 duty.
- Noise pressure level $L_p \leq 70$ dB(A). Conditions: distance 1 m; measured without load an input speed of $n_1 = 3000 \text{ min}^{-1}$; $i=10$.
- Bearings suitably rated for an average service life of 20,000 hours under nominal operating conditions. The following chart shows the types of bearings for the output shaft.

MP

	MP 053	MP 060	MP 080	MP 105	MP 130	MP 160	MP 190
SB							
HB							

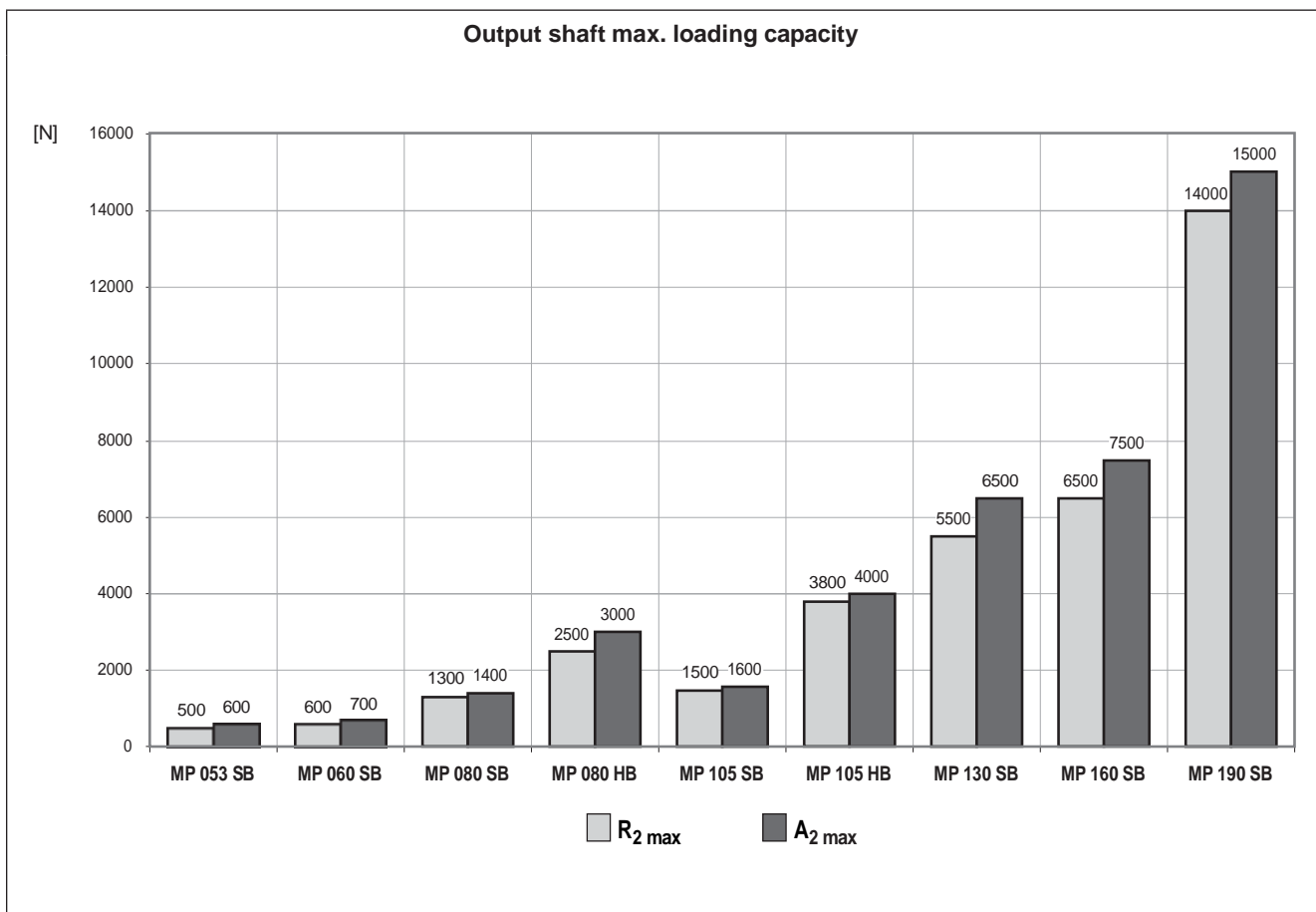

- Wide range of adapter flanges matching the most popular brands of motors.



- Lubrication optimized for the type of duty specified when ordering.
In the absence of contamination the lubricant requires no periodical changes.

duty	MP 053 - MP 060	MP 080 ... MP 190	oil seals
S1 (continuous)	NLGI grease consistency 00	Synthetic oil viscosity ISO VG 220	Fluoroelastomer
S5 (intermittent)		NLGI grease consistency 00	NBR

- Ambient temperature min -20°C, max +30°C. For temperature higher than 30°C please consider derating factor f_T .
- Housing temperature must not exceed $T_{max} = 90^\circ\text{C}$.

		Distribution of nominal torque M_{n2} [Nm]																											
		3	4	5	6	7	9	10	12	15	16	20	25	28	30	35	36	40	45	48	50	60	64	70	75	80	81	84	90
MP 053	[I]	12	15	15	15	15	12	-	20	20	20	20	20	20	-	20	15	-	20	20	-	20	20	-	20	20	12	20	-
MP 060	[I]	18	25	25	25	25	18	18	30	30	30	30	30	30	18	30	25	30	-	30	30	-	30	30	30	30	-	30	18
MP 080	[I]	40	50	50	50	50	40	40	70	70	70	70	70	70	40	70	50	70	-	70	70	-	70	70	70	70	-	70	40
MP 105	[I]	100	140	140	140	140	100	100	170	170	170	170	170	170	100	170	140	170	-	170	170	-	170	170	170	170	-	170	100
MP 130	[I]	215	380	380	380	380	215	215	450	450	450	450	450	450	215	450	380	450	-	450	450	-	450	450	450	450	-	450	215
MP 160	[I]	350	500	500	500	500	350	350	700	700	700	700	700	700	350	700	500	700	-	700	700	-	700	700	700	700	-	700	350
MP 190	[I]	500	700	700	700	700	500	500	1000	1000	1000	1000	1000	1000	500	1000	700	1000	-	1000	1000	-	1000	1000	1000	1000	-	1000	500
MP 053	[II]	100	112	120	125	140	144	150	160	175	180	200	210	216	225	245	250	252	280	324	350	400	405	500	567	700	729	1000	
MP 060	[II]	20	20	-	20	20	20	-	-	20	20	-	-	20	20	20	-	20	-	20	-	-	20	-	20	-	12	-	
MP 080	[II]	18	-	30	30	30	-	30	30	30	-	30	30	30	-	-	30	-	30	-	30	30	-	30	-	30	-	18	
MP 105	[II]	40	-	70	70	70	-	70	70	70	-	70	70	70	-	-	70	-	70	-	70	70	-	70	-	70	-	40	
MP 130	[II]	100	-	170	170	170	-	170	170	170	-	170	170	170	-	-	170	-	170	-	170	170	-	170	-	170	-	100	
MP 160	[II]	215	-	450	450	450	-	450	450	450	-	450	450	450	-	-	450	-	450	-	450	450	-	450	-	450	-	215	
MP 190	[II]	700	-	350	700	700	-	700	700	700	-	700	700	-	-	700	-	700	-	700	700	-	700	700	-	700	-	350	
MP 190	[II]	1000	-	500	1000	1000	-	1000	1000	1000	-	1000	1000	-	-	1000	-	1000	-	1000	1000	-	1000	1000	-	1000	-	500	

6.1 ORDERING CODE

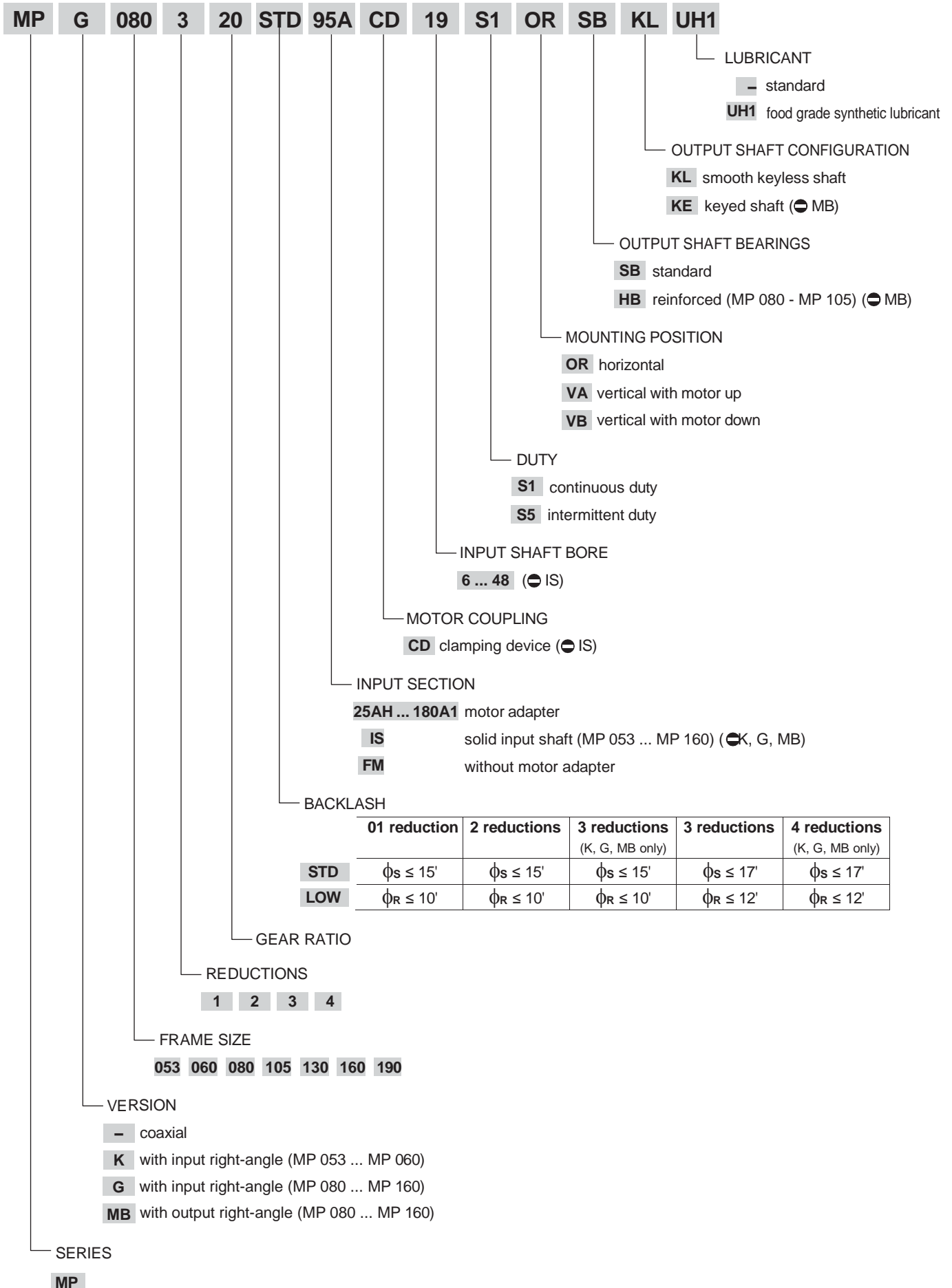

MP

6.1.1 VERSION AND INPUT SECTION

INPUT SECTION	VERSION		
	coaxial (—)	with input right-angle (K - G)	with output right-angle (MB)
25AH ... 180A1			
IS			
FM			

6.1.2 MOUNTING POSITIONS

	OR	VA	VB
—			
K - G			
MB			

IMP

6.1.3 ADMISSIBLE RADIAL AND AXIAL FORCES FOR MB VERSION

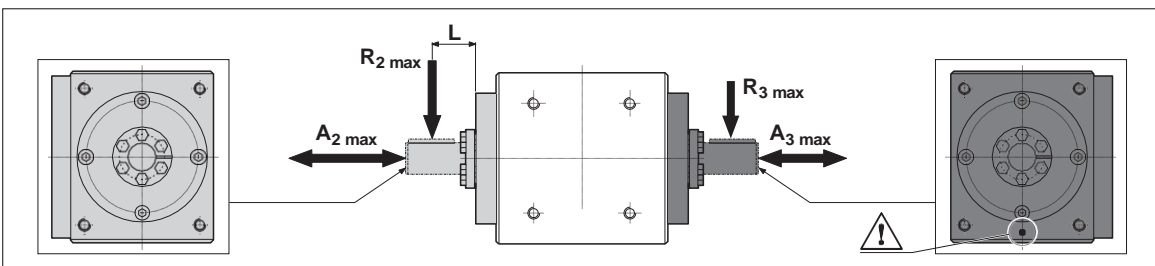

	$R_2 \text{ max}$ [N]	$A_2 \text{ max}$ [N]	L [mm]	$R_3 \text{ max}$ [N]	$A_3 \text{ max}$ [N]
MP MB 080	6000	5000	60	5500	5000
MP MB 105	9000	7500	80	7500	7500
MP MB 130	13500	11500	100	11000	11500
MP MB 160*	15000	11500	100	12500	11500

* Bearings suitably rated for an average service life of 10,000 hours under nominal operating conditions.

6.2 DIMENSIONS AND TECHNICAL SPECIFICATIONS

MP 053

IS

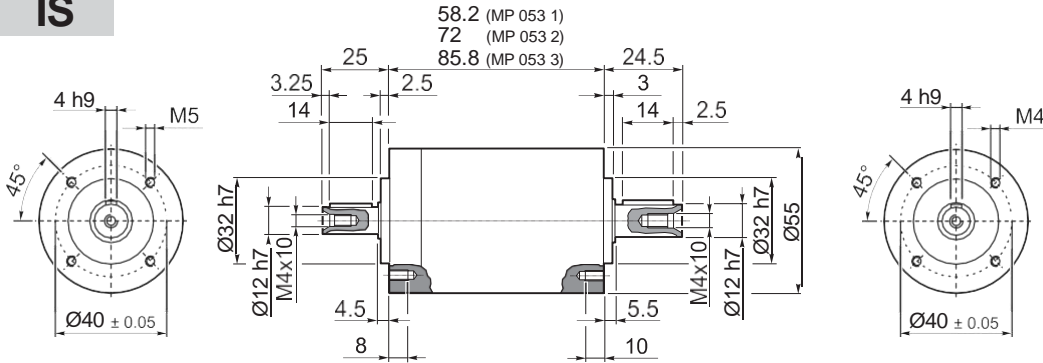

MP 053 1	0.8
MP 053 2	1.0
MP 053 3	1.3

25AH ... 80A

MP

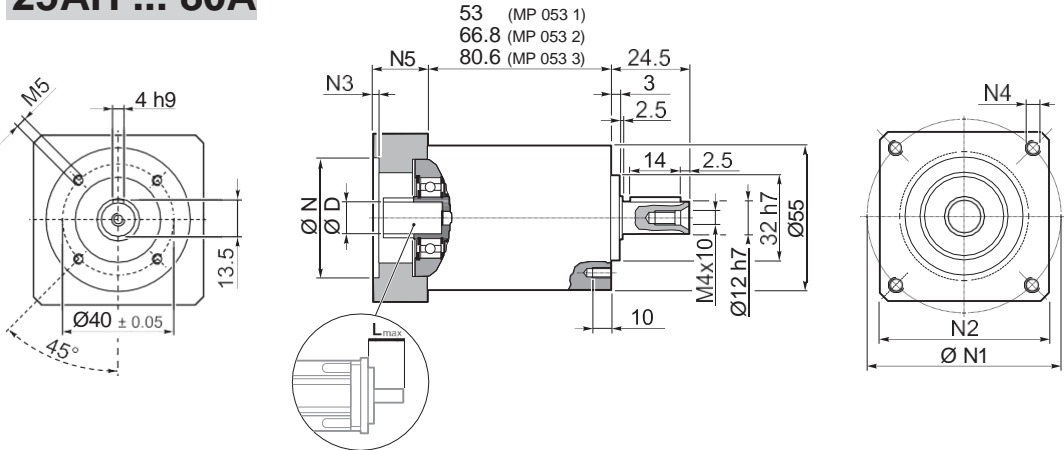

MP 053 1	0.8
MP 053 2	1.0
MP 053 3	1.3

											N	N1		N2	N3	N4	N5	L _{max}
	6	6.35	7	8	9	9.52	10	11	12	12.7		min	max					
25AH	6	6.35	7	8	9	9.52	-	-	-	-	25	36	48					
26AH	6	6.35	7	8	9	9.52	-	-	-	-	26	36	48					
28AH	6	6.35	7	8	9	9.52	-	-	-	-	28	36	48					
30AH	6	6.35	7	8	9	9.52	-	-	-	-	30	36	48					
32AH	6	6.35	7	8	9	9.52	-	-	-	-	32	38	48	55	3.5	4.5	25	25
34AH	6	6.35	7	8	9	9.52	-	-	-	-	34	40	48					
36AH	6	6.35	7	8	9	9.52	-	-	-	-	36	42	48					
38AH	6	6.35	7	8	9	9.52	-	-	-	-	38	44	48					
40AH	6	6.35	7	8	9	9.52	-	-	-	-	40	46	48					
38B	6	6.35	7	8	9	9.52	10	11	12	12.7	38.1	66.6		60	3	M4x10	18	25
40B	6	6.35	7	8	9	9.52	10	11	12	12.7	40	63		60	3	M4x10	18	25
50A	6	6.35	7	8	9	9.52	10	11	12	12.7	50	60		60	3	M4x10	18	25
50B	6	6.35	7	8	9	9.52	10	11	12	12.7	50	65		60	3	M5x12	23	30
50BH	6	6.35	7	8	9	9.52	10	11	12	12.7	50	65		60	4	5.5	23	30
50C	6	6.35	7	8	9	9.52	10	11	12	12.7	50	70		60	3	M4x10	23	30
50MH	6	6.35	7	8	9	9.52	10	11	12	12.7	50	65		55	2	5.5	16	23
60A	6	6.35	7	8	9	9.52	10	11	12	12.7	60	75		65	3	M5x12	18	25
60AH	6	6.35	7	8	9	9.52	10	11	12	12.7	60	75		65	3	5.5	18	25
60A1	6	6.35	7	8	9	9.52	10	11	12	12.7	60	75		65	3	M5x12	23	30
60AH1	6	6.35	7	8	9	9.52	10	11	12	12.7	60	75		65	3	5.5	23	30
60B	6	6.35	7	8	9	9.52	10	11	12	12.7	60	85		75	3	M5x12	23	30
60C	6	6.35	7	8	9	9.52	10	11	12	12.7	60	90		75	3	M5x12	23	30
70A	6	6.35	7	8	9	9.52	10	11	12	12.7	70	85		75	3	M6x15	23	30
70B	6	6.35	7	8	9	9.52	10	11	12	12.7	70	90		75	5	M5x12	23	30
73A	6	6.35	7	8	9	9.52	10	11	12	12.7	73	98.4		85	3	M5x12	25	32
80A	6	6.35	7	8	9	9.52	10	11	12	12.7	80	100		85	3	M6x15	23	30

MP 053

FM

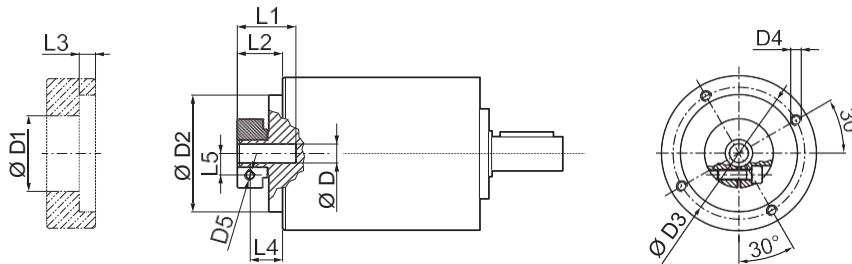

				D1	D2	D3	D4	D5	L1	L2	L3	L4	L5
6	6.35	7		32.5	50	42.5	M4x8	M4	20.2	13.2	3	8.7	8
8	9	9.52	10	32.5	50	42.5	M4x8	M4	20.2	13.2	3	7.8	9
11	12	12.7		35.5	50	42.5	M4x8	M4	20.5	13.5	3	8.5	11
14				35.5	50	42.5	M4x8	M4	24	17	3	10.2	11.5

	i	M _{n2}	M _{a2}	M _{p2}	n ₁	n _{1 max}	φ _S	φ _R	C _t	R _{1 max}	R _{2 max}	A _{2 max}	η	J _G [kgcm ²]	
		[Nm]	[Nm]	[Nm]	[min ⁻¹]	[min ⁻¹]	[arcmin]	[arcmin]	[$\frac{Nm}{arcmin}$]	[N]	[N]	[N]	%		6 ... 9.52
MP 053 1_3		12	22	40	3300	4000	15'	10'	1.0	200	500	600	97	0.06	0.08
MP 053 1_4		15	28	45	3500	5000	15'	10'	1.0	200	500	600	97	0.05	0.06
MP 053 1_5		15	28	45	3500	5000	15'	10'	1.0	200	500	600	97	0.04	0.06
MP 053 1_6		15	28	45	3500	5000	15'	10'	1.0	200	500	600	97	0.03	0.05
MP 053 1_7		15	28	45	4000	6000	15'	10'	1.0	200	500	600	97	0.03	0.05
MP 053 1_9		12	22	40	4000	6000	15'	10'	1.0	200	500	600	97	0.03	0.05
MP 053 2_12		20	30	60	3300	4000	15'	10'	0.9	200	500	600	94	0.06	0.08
MP 053 2_15		20	30	60	3300	4000	15'	10'	0.9	200	500	600	94	0.06	0.08
MP 053 2_16		20	30	60	3500	5000	15'	10'	0.9	200	500	600	94	0.05	0.06
MP 053 2_20		20	30	60	3500	5000	15'	10'	0.9	200	500	600	94	0.04	0.06
MP 053 2_25		20	30	60	3500	5000	15'	10'	0.9	200	500	600	94	0.04	0.06
MP 053 2_28		20	30	60	4000	6000	15'	10'	0.9	200	500	600	94	0.03	0.05
MP 053 2_35		20	30	60	4000	6000	15'	10'	0.9	200	500	600	94	0.03	0.05
MP 053 2_36		15	28	45	4000	6000	15'	10'	0.9	200	500	600	94	0.03	0.05
MP 053 2_45		20	30	60	4000	6000	15'	10'	0.9	200	500	600	94	0.03	0.05
MP 053 2_81		12	22	40	4000	6000	15'	10'	0.9	200	500	600	94	0.03	0.05
MP 053 3_48		20	30	60	4000	5000	17'	12'	0.7	200	500	600	91	0.05	0.07
MP 053 3_60		20	30	60	3500	5000	17'	12'	0.7	200	500	600	91	0.05	0.07
MP 053 3_64		20	30	60	3500	5000	17'	12'	0.7	200	500	600	91	0.05	0.06
MP 053 3_75		20	30	60	3500	5000	17'	12'	0.7	200	500	600	91	0.04	0.06
MP 053 3_80		20	30	60	3500	5000	17'	12'	0.7	200	500	600	91	0.05	0.06
MP 053 3_84		20	30	60	4000	6000	17'	12'	0.7	200	500	600	91	0.03	0.05
MP 053 3_100		20	30	60	3500	5000	17'	12'	0.7	200	500	600	91	0.04	0.06
MP 053 3_112		20	30	60	4000	6000	17'	12'	0.7	200	500	600	91	0.03	0.05
MP 053 3_125		20	30	60	3500	5000	17'	12'	0.7	200	500	600	91	0.04	0.06
MP 053 3_140		20	30	60	4000	6000	17'	12'	0.7	200	500	600	91	0.03	0.05
MP 053 3_144		20	30	60	4000	6000	17'	12'	0.7	200	500	600	91	0.03	0.05
MP 053 3_175		20	30	60	4000	6000	17'	12'	0.7	200	500	600	91	0.03	0.05
MP 053 3_180		20	30	60	4000	6000	17'	12'	0.7	200	500	600	91	0.03	0.05
MP 053 3_216		20	30	60	3500	5000	17'	12'	0.7	200	500	600	91	0.03	0.05
MP 053 3_225		20	30	60	4000	6000	17'	12'	0.7	200	500	600	91	0.03	0.05
MP 053 3_245		20	30	60	4000	6000	17'	12'	0.7	200	500	600	91	0.03	0.05
MP 053 3_252		20	30	60	4000	6000	17'	12'	0.7	200	500	600	91	0.05	0.06
MP 053 3_324		20	30	60	4000	6000	17'	12'	0.7	200	500	600	91	0.03	0.05
MP 053 3_405		20	30	60	4000	6000	17'	12'	0.7	200	500	600	91	0.03	0.05
MP 053 3_567		20	30	60	4000	6000	17'	12'	0.7	200	500	600	91	0.03	0.05
MP 053 3_729		12	22	40	4000	6000	17'	12'	0.7	200	500	600	91	0.03	0.05

MP

Please contact us for different motor adapters and input shaft bore.

MP K 053

25AH ... 80A

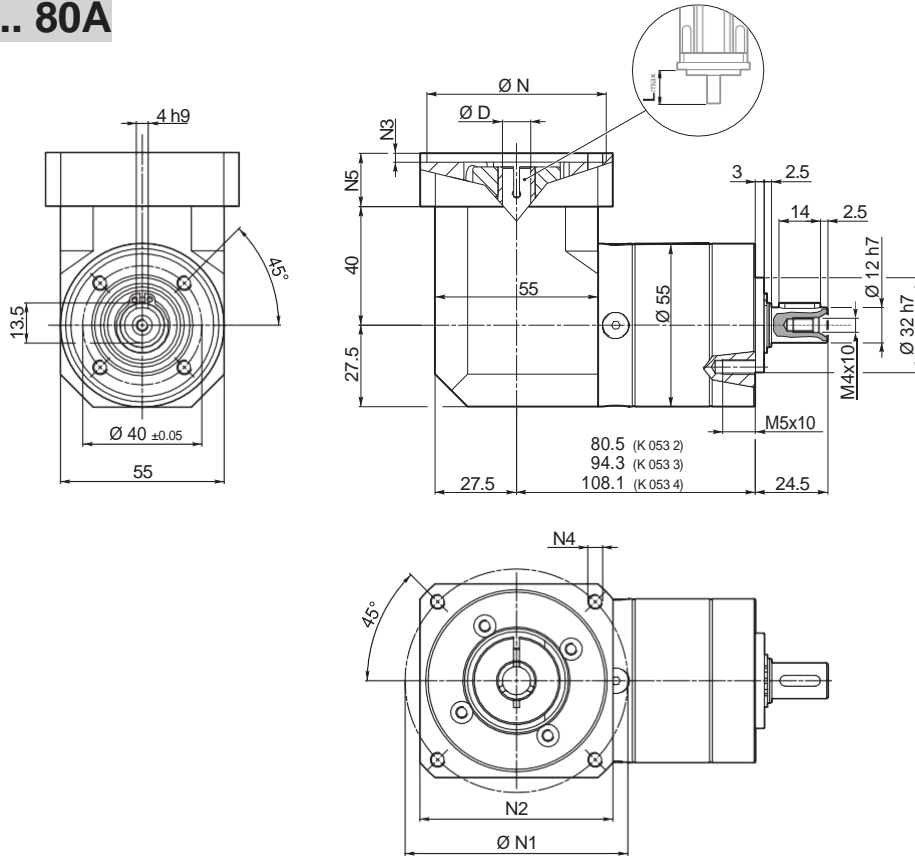

	MP K 053 2	1.3
	MP K 053 3	1.5
	MP K 053 4	1.8

MP

												N	N1		N2	N3	N4	N5	L _{max}
	min	max	min	max															
25AH	6	6.35	7	8	9	9.52	-	-	-	-	-	25	36	48					
26AH	6	6.35	7	8	9	9.52	-	-	-	-	-	26	36	48					
28AH	6	6.35	7	8	9	9.52	-	-	-	-	-	28	36	48					
30AH	6	6.35	7	8	9	9.52	-	-	-	-	-	30	36	48					
32AH	6	6.35	7	8	9	9.52	-	-	-	-	-	32	38	48	55	3.5	4.5	25	25
34AH	6	6.35	7	8	9	9.52	-	-	-	-	-	34	40	48					
36AH	6	6.35	7	8	9	9.52	-	-	-	-	-	36	42	48					
38AH	6	6.35	7	8	9	9.52	-	-	-	-	-	38	44	48					
40AH	6	6.35	7	8	9	9.52	-	-	-	-	-	40	46	48					
38B	6	6.35	7	8	9	9.52	10	11	12	12.7	-	38.1	66.6	60	3	M4x10	18	25	
40B	6	6.35	7	8	9	9.52	10	11	12	12.7	-	40	63	60	3	M4x10	18	25	
50A	6	6.35	7	8	9	9.52	10	11	12	12.7	-	50	60	60	3	M4x10	18	25	
50B	6	6.35	7	8	9	9.52	10	11	12	12.7	14	50	65	60	3	M5x12	23	30	
50BH	6	6.35	7	8	9	9.52	10	11	12	12.7	14	50	65	60	4	5.5	23	30	
50C	6	6.35	7	8	9	9.52	10	11	12	12.7	14	50	70	60	3	M4x10	23	30	
50MH	6	6.35	7	8	9	9.52	10	11	12	12.7	-	50	65	55	2	5.5	16	23	
60A	6	6.35	7	8	9	9.52	10	11	12	12.7	-	60	75	65	3	M5x12	18	25	
60A1	6	6.35	7	8	9	9.52	10	11	12	12.7	14	60	75	65	3	M5x12	23	30	
60B	6	6.35	7	8	9	9.52	10	11	12	12.7	14	60	85	75	3	M5x12	23	30	
60C	6	6.35	7	8	9	9.52	10	11	12	12.7	14	60	90	75	3	M5x12	23	30	
70A	6	6.35	7	8	9	9.52	10	11	12	12.7	14	70	85	75	3	M6x15	23	30	
70B	6	6.35	7	8	9	9.52	10	11	12	12.7	14	70	90	75	5	M5x12	23	30	
73A	6	6.35	7	8	9	9.52	10	11	12	12.7	14	73	98.4	85	3	M5x12	25	32	
80A	6	6.35	7	8	9	9.52	10	11	12	12.7	14	80	100	85	3	M6x15	23	30	

MP K 053

FM

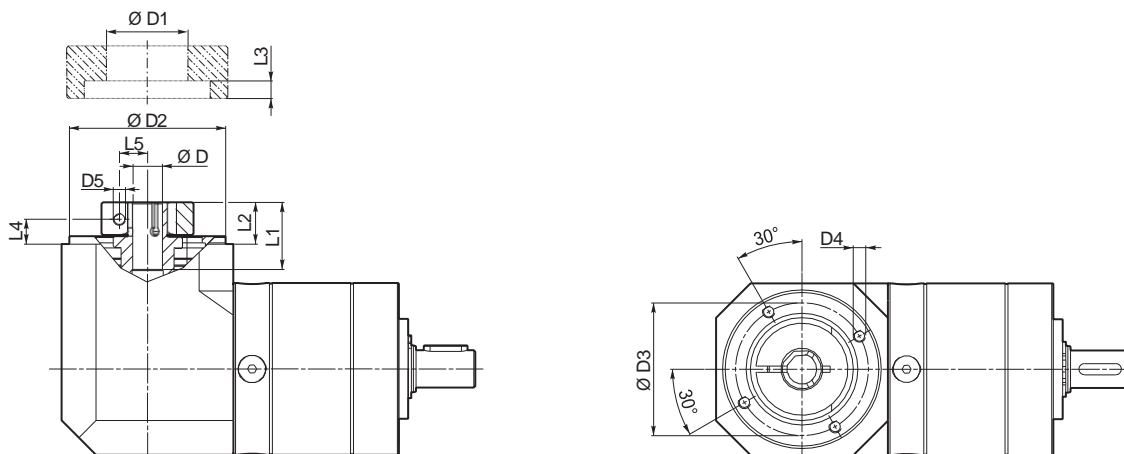

D				D1	D2	D3	D4	D5	L1	L2	L3	L4	L5
6	6.35	7		32.5	50	42.5	M4x8	M4	20.2	13.2	3	8.7	8
8	9	9.52	10	32.5	50	42.5	M4x8	M4	20.2	13.2	3	7.8	9
11	12	12.7		35.5	50	42.5	M4x8	M4	20.5	13.5	3	8.5	11
14				35.5	50	42.5	M4x8	M4	24	17	3	10.2	11.5

i	M _{n 2} [Nm]	M _{a 2} [Nm]	M _{p 2} [Nm]	n ₁ [min ⁻¹]	n _{1 max} [min ⁻¹]	φ _S [arcmin]	φ _R [arcmin]	C _t [Nm/arcmin]	R _{2 max} [N]	A _{2 max} [N]	η %	J _G [kgcm ²]	
												D	
MP K 053 2_3	12	22	40	3300	4000	15'	10'	1.0	500	600	94	0.18	0.20
MP K 053 2_4	15	28	45	3500	5000	15'	10'	1.0	500	600	94	0.18	0.19
MP K 053 2_5	15	28	45	3500	5000	15'	10'	1.0	500	600	94	0.17	0.19
MP K 053 2_6	15	28	45	3500	5000	15'	10'	1.0	500	600	94	0.17	0.18
MP K 053 2_7	15	28	45	4000	6000	15'	10'	1.0	500	600	94	0.17	0.19
MP K 053 2_9	12	22	40	4000	6000	15'	10'	1.0	500	600	94	0.17	0.18
MP K 053 3_12	20	30	60	3300	4000	15'	10'	0.9	500	600	91	0.18	0.20
MP K 053 3_15	20	30	60	3300	4000	15'	10'	0.9	500	600	91	0.18	0.20
MP K 053 3_16	20	30	60	3500	5000	15'	10'	0.9	500	600	91	0.17	0.19
MP K 053 3_20	20	30	60	3500	5000	15'	10'	0.9	500	600	91	0.17	0.19
MP K 053 3_25	20	30	60	3500	5000	15'	10'	0.9	500	600	91	0.17	0.19
MP K 053 3_28	20	30	60	4000	6000	15'	10'	0.9	500	600	91	0.17	0.19
MP K 053 3_35	20	30	60	4000	6000	15'	10'	0.9	500	600	91	0.17	0.19
MP K 053 3_36	15	28	45	4000	6000	15'	10'	0.9	500	600	91	0.17	0.18
MP K 053 3_45	20	30	60	4000	6000	15'	10'	0.9	500	600	91	0.17	0.19
MP K 053 3_81	12	22	40	4000	6000	15'	10'	0.9	500	600	91	0.17	0.18
MP K 053 4_48	20	30	60	4000	5000	17'	12'	0.7	500	600	89	0.18	0.19
MP K 053 4_60	20	30	60	3500	5000	17'	12'	0.7	500	600	89	0.18	0.19
MP K 053 4_64	20	30	60	3500	5000	17'	12'	0.7	500	600	89	0.17	0.19
MP K 053 4_75	20	30	60	3500	5000	17'	12'	0.7	500	600	89	0.17	0.19
MP K 053 4_80	20	30	60	3500	5000	17'	12'	0.7	500	600	89	0.17	0.19
MP K 053 4_84	20	30	60	4000	6000	17'	12'	0.7	500	600	89	0.17	0.19
MP K 053 4_100	20	30	60	3500	5000	17'	12'	0.7	500	600	89	0.17	0.19
MP K 053 4_112	20	30	60	4000	6000	17'	12'	0.7	500	600	89	0.17	0.19
MP K 053 4_125	20	30	60	3500	5000	17'	12'	0.7	500	600	89	0.17	0.19
MP K 053 4_140	20	30	60	4000	6000	17'	12'	0.7	500	600	89	0.17	0.19
MP K 053 4_144	20	30	60	4000	6000	17'	12'	0.7	500	600	89	0.17	0.18
MP K 053 4_175	20	30	60	4000	6000	17'	12'	0.7	500	600	89	0.17	0.19
MP K 053 4_180	20	30	60	4000	6000	17'	12'	0.7	500	600	89	0.17	0.18
MP K 053 4_216	20	30	60	3500	5000	17'	12'	0.7	500	600	89	0.17	0.18
MP K 053 4_225	20	30	60	4000	6000	17'	12'	0.7	500	600	89	0.17	0.18
MP K 053 4_245	20	30	60	4000	6000	17'	12'	0.7	500	600	89	0.17	0.19
MP K 053 4_252	20	30	60	4000	6000	17'	12'	0.7	500	600	89	0.18	0.20
MP K 053 4_324	20	30	60	4000	6000	17'	12'	0.7	500	600	89	0.17	0.18
MP K 053 4_405	20	30	60	4000	6000	17'	12'	0.7	500	600	89	0.17	0.18
MP K 053 4_567	20	30	60	4000	6000	17'	12'	0.7	500	600	89	0.17	0.18
MP K 053 4_729	12	22	40	4000	6000	17'	12'	0.7	500	600	89	0.17	0.18

MP

Please contact us for different motor adapters and input shaft bore.

MP 060

IS

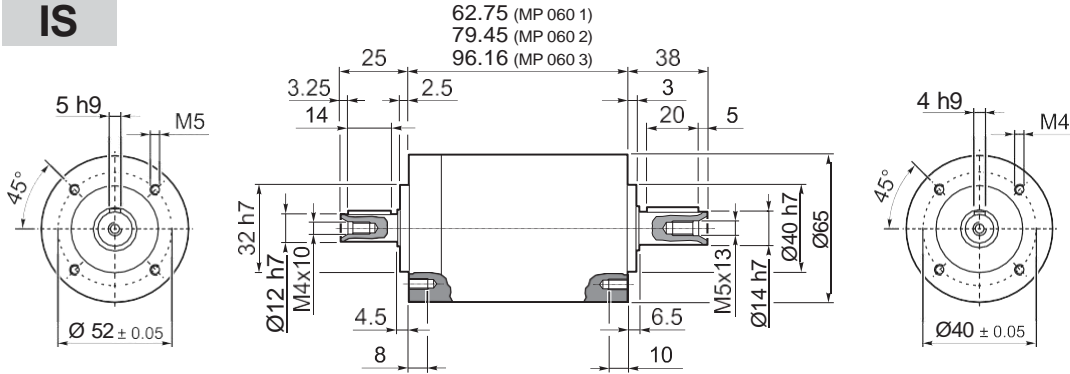

MP 060 1	1.2
MP 060 2	1.7
MP 060 3	2.0

25AH ... 80A

MP

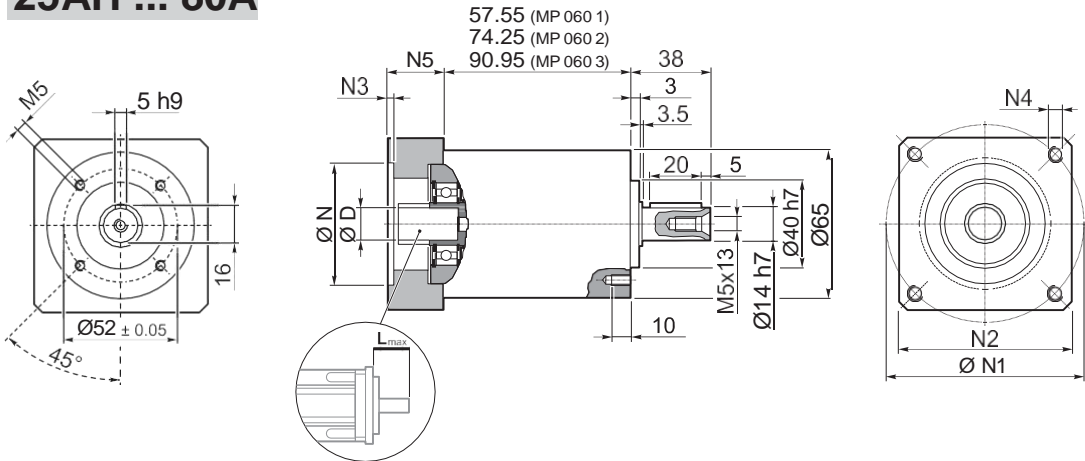

MP 060 1	1.2
MP 060 2	1.7
MP 060 3	2.0

											N	N1		N2	N3	N4	N5	Lmax	
	D											min	max						
25AH	6	6.35	7	8	9	9.52	-	-	-	-	25	39	56						
26AH	6	6.35	7	8	9	9.52	-	-	-	-	26	39	56						
28AH	6	6.35	7	8	9	9.52	-	-	-	-	28	39	56						
30AH	6	6.35	7	8	9	9.52	-	-	-	-	30	39	56						
32AH	6	6.35	7	8	9	9.52	-	-	-	-	32	39	56	65	3.5	4.5	25	25	
34AH	6	6.35	7	8	9	9.52	-	-	-	-	34	40	56						
36AH	6	6.35	7	8	9	9.52	-	-	-	-	36	42	56						
39AH	6	6.35	7	8	9	9.52	-	-	-	-	39	45	56						
40AH	6	6.35	7	8	9	9.52	-	-	-	-	40	46	56						
38B	6	6.35	7	8	9	9.52	10	11	12	12.7	-	38.1	66.6		60	3	M4x10	18	25
40B	6	6.35	7	8	9	9.52	10	11	12	12.7	-	40	63		60	3	M4x10	18	25
50A	6	6.35	7	8	9	9.52	10	11	12	12.7	-	50	60		60	3	M4x10	18	25
50B	6	6.35	7	8	9	9.52	10	11	12	12.7	14	50	65		60	3	M5x12	23	30
50BH	6	6.35	7	8	9	9.52	10	11	12	12.7	14	50	65		65	3	5.5	25	32
50C	6	6.35	7	8	9	9.52	10	11	12	12.7	14	50	70		60	3	M4x10	23	30
55MH	6	6.35	7	8	9	9.52	10	11	12	12.7	-	55	80		65	2	5.5	16	23
60A	6	6.35	7	8	9	9.52	10	11	12	12.7	-	60	75		65	3	M5x12	18	25
60AH	6	6.35	7	8	9	9.52	10	11	12	12.7	-	60	75		65	3	5.5	18	25
60A1	6	6.35	7	8	9	9.52	10	11	12	12.7	14	60	75		65	3	M5x12	23	30
60AH1	6	6.35	7	8	9	9.52	10	11	12	12.7	14	60	75		65	3	5.5	23	30
60B	6	6.35	7	8	9	9.52	10	11	12	12.7	14	60	85		75	3	M5x12	23	30
60C	6	6.35	7	8	9	9.52	10	11	12	12.7	14	60	90		75	3	M5x12	23	30
70A	6	6.35	7	8	9	9.52	10	11	12	12.7	14	70	85		75	3	M6x15	23	30
70B	6	6.35	7	8	9	9.52	10	11	12	12.7	14	70	90		75	5	M5x12	23	30
73A	6	6.35	7	8	9	9.52	10	11	12	12.7	14	73	98.4		85	3	M5x12	25	32
80A	6	6.35	7	8	9	9.52	10	11	12	12.7	14	80	100		85	3	M6x15	23	30

MP 060

FM

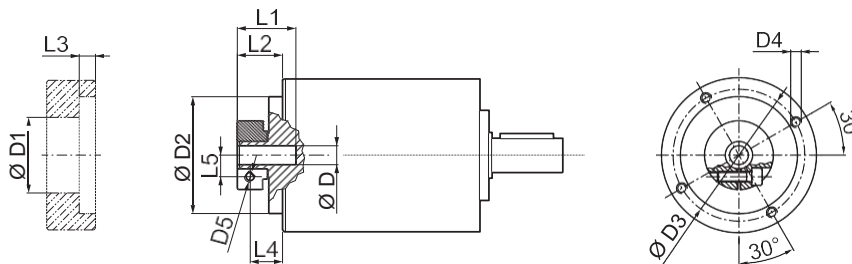

				D1	D2	D3	D4	D5	L1	L2	L3	L4	L5
6	6.35	7		32.5	50	42.5	M4x8	M4	20.2	13.2	3	8.7	8
8	9	9.52	10	32.5	50	42.5	M4x8	M4	20.2	13.2	3	7.8	9
11	12	12.7		35.5	50	42.5	M4x8	M4	20.5	13.5	3	8.5	11
14				35.5	50	42.5	M4x8	M4	24	17	3	10.2	11.5

	i	M _{n 2}	M _{a 2}	M _{p 2}	n ₁	n _{1 max}	φ _S	φ _R	C _t	R _{1 max}	R _{2 max}	A _{2 max}	η	J _G [kgcm ²]	
		[Nm]	[Nm]	[Nm]	[min ⁻¹]	[min ⁻¹]	[arcmin]	[arcmin]	[Nm/arcmin]	[N]	[N]	[N]	%	6 ... 9.52	10 ... 14
MP 060 1_3		18	35	70	3300	4000	15'	10'	3.0	200	600	700	97	0.10	0.11
MP 060 1_4		25	40	90	3500	5000	15'	10'	3.0	200	600	700	97	0.06	0.08
MP 060 1_5		25	40	90	3500	5000	15'	10'	3.0	200	600	700	97	0.05	0.07
MP 060 1_6		25	40	90	3500	5000	15'	10'	3.0	200	600	700	97	0.04	0.06
MP 060 1_7		25	40	90	4000	6000	15'	10'	3.0	200	600	700	97	0.04	0.06
MP 060 1_10		18	35	70	4000	6000	15'	10'	3.0	200	600	700	97	0.03	0.05
MP 060 2_9		18	35	70	3300	4000	15'	10'	2.5	200	600	700	94	0.10	0.12
MP 060 2_12		30	45	100	3300	4000	15'	10'	2.5	200	600	700	94	0.10	0.11
MP 060 2_15		30	45	100	3300	4000	15'	10'	2.5	200	600	700	94	0.09	0.11
MP 060 2_16		30	45	100	3500	5000	15'	10'	2.5	200	600	700	94	0.06	0.08
MP 060 2_20		30	45	100	3500	5000	15'	10'	2.5	200	600	700	94	0.05	0.07
MP 060 2_25		30	45	100	3500	5000	15'	10'	2.5	200	600	700	94	0.05	0.06
MP 060 2_28		30	45	100	4000	6000	15'	10'	2.5	200	600	700	94	0.04	0.06
MP 060 2_30		18	35	70	4000	6000	15'	10'	2.5	200	600	700	94	0.03	0.05
MP 060 2_35		30	45	100	4000	6000	15'	10'	2.5	200	600	700	94	0.04	0.06
MP 060 2_36		25	40	90	3500	5000	15'	10'	2.5	200	600	700	94	0.04	0.06
MP 060 2_40		30	45	100	4000	6000	15'	10'	2.5	200	600	700	94	0.03	0.05
MP 060 2_50		30	45	100	4000	6000	15'	10'	2.5	200	600	700	94	0.03	0.05
MP 060 2_70		30	45	100	4000	6000	15'	10'	2.5	200	600	700	94	0.03	0.05
MP 060 2_100		18	35	70	4000	6000	15'	10'	2.5	200	600	700	94	0.03	0.05
MP 060 3_48		30	45	100	3500	5000	17'	12'	1.8	200	600	700	91	0.06	0.08
MP 060 3_64		30	45	100	3500	5000	17'	12'	1.8	200	600	700	91	0.06	0.08
MP 060 3_75		30	45	100	3500	5000	17'	12'	1.8	200	600	700	91	0.05	0.07
MP 060 3_80		30	45	100	3500	5000	17'	12'	1.8	200	600	700	91	0.06	0.08
MP 060 3_84		30	45	100	4000	6000	17'	12'	1.8	200	600	700	91	0.04	0.06
MP 060 3_90		18	35	70	4000	6000	17'	12'	1.8	200	600	700	91	0.03	0.05
MP 060 3_120		30	45	100	4000	6000	17'	12'	1.8	200	600	700	91	0.03	0.05
MP 060 3_125		30	45	100	3500	5000	17'	12'	1.8	200	600	700	91	0.05	0.07
MP 060 3_140		30	45	100	4000	6000	17'	12'	1.8	200	600	700	91	0.04	0.06
MP 060 3_150		30	45	100	4000	6000	17'	12'	1.8	200	600	700	91	0.03	0.05
MP 060 3_160		30	45	100	4000	6000	17'	12'	1.8	200	600	700	91	0.03	0.05
MP 060 3_175		30	45	100	4000	6000	17'	12'	1.8	200	600	700	91	0.04	0.06
MP 060 3_200		30	45	100	4000	6000	17'	12'	1.8	200	600	700	91	0.03	0.05
MP 060 3_210		30	45	100	4000	6000	17'	12'	1.8	200	600	700	91	0.03	0.05
MP 060 3_216		30	45	100	3500	5000	17'	12'	1.8	200	600	700	91	0.04	0.06
MP 060 3_250		30	45	100	4000	6000	17'	12'	1.8	200	600	700	91	0.03	0.05
MP 060 3_280		30	45	100	4000	6000	17'	12'	1.8	200	600	700	91	0.03	0.05
MP 060 3_350		30	45	100	4000	6000	17'	12'	1.8	200	600	700	91	0.03	0.05
MP 060 3_400		30	45	100	4000	6000	17'	12'	1.8	200	600	700	91	0.03	0.05
MP 060 3_500		30	45	100	4000	6000	17'	12'	1.8	200	600	700	91	0.03	0.05
MP 060 3_700		30	45	100	4000	6000	17'	12'	1.8	200	600	700	91	0.03	0.05
MP 060 3_1000		18	35	70	4000	6000	17'	12'	1.8	200	600	700	91	0.03	0.05

MP

Please contact us for different motor adapters and input shaft bore.

MP K 060

25AH ... 80A

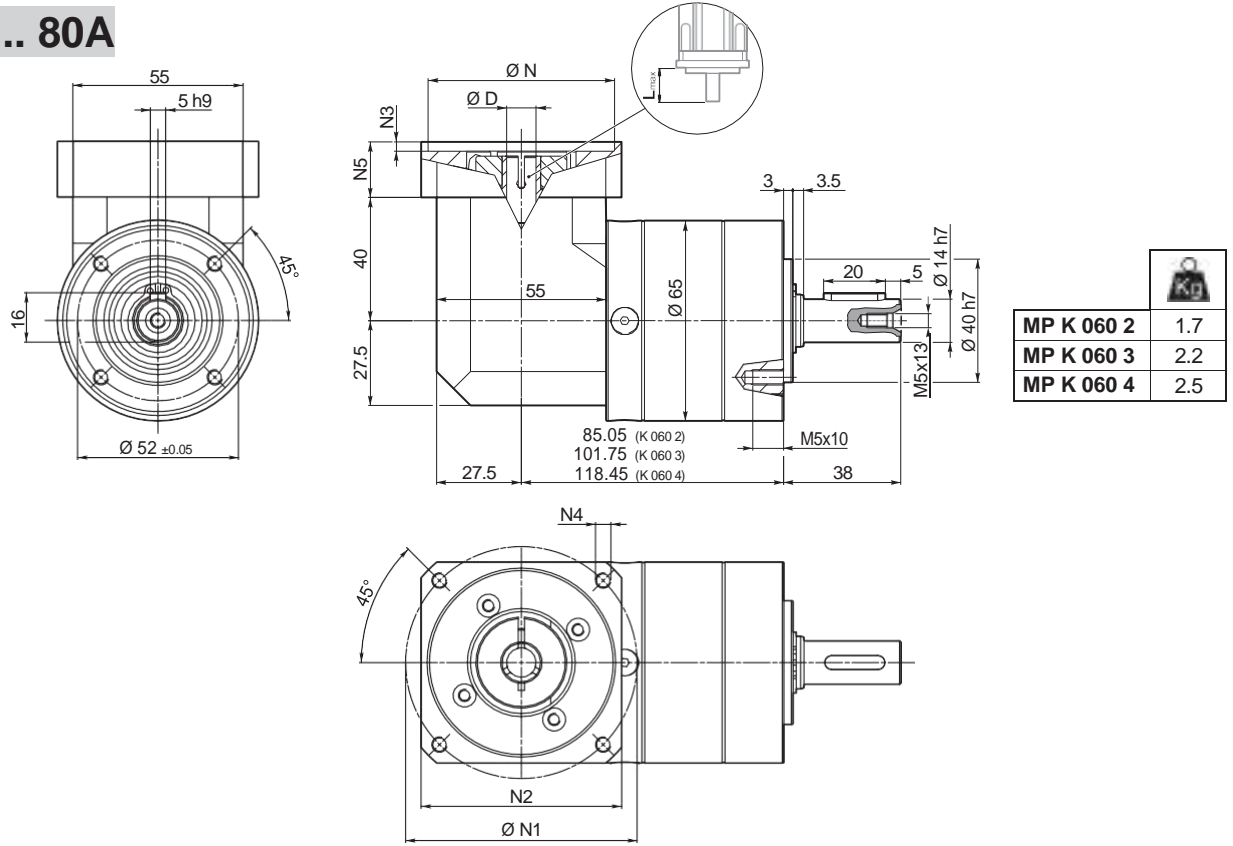

MP

Image	D	N	N1		N2	N3	N4	N5	L _{max}
			min	max					
25AH	6 6.35 7 8 9 9.52 - - - - -	25	39	56					
26AH	6 6.35 7 8 9 9.52 - - - - -	26	39	56					
28AH	6 6.35 7 8 9 9.52 - - - - -	28	39	56					
30AH	6 6.35 7 8 9 9.52 - - - - -	30	39	56					
32AH	6 6.35 7 8 9 9.52 - - - - -	32	39	56	65	3.5	4.5	25	25
34AH	6 6.35 7 8 9 9.52 - - - - -	34	40	56					
36AH	6 6.35 7 8 9 9.52 - - - - -	36	42	56					
39AH	6 6.35 7 8 9 9.52 - - - - -	39	45	56					
40AH	6 6.35 7 8 9 9.52 - - - - -	40	46	56					
38B	6 6.35 7 8 9 9.52 10 11 12 12.7 -	38.1	66.6		60	3	M4x10	18	25
40B	6 6.35 7 8 9 9.52 10 11 12 12.7 -	40	63		60	3	M4x10	18	25
50A	6 6.35 7 8 9 9.52 10 11 12 12.7 -	50	60		60	3	M4x10	18	25
50B	6 6.35 7 8 9 9.52 10 11 12 12.7 14	50	65		60	3	M5x12	23	30
50BH	6 6.35 7 8 9 9.52 10 11 12 12.7 14	50	65		65	3	5.5	25	32
50C	6 6.35 7 8 9 9.52 10 11 12 12.7 14	50	70		60	3	M4x10	23	30
55MH	6 6.35 7 8 9 9.52 10 11 12 12.7 -	55	80		65	2	5.5	16	23
60A	6 6.35 7 8 9 9.52 10 11 12 12.7 -	60	75		65	3	M5x12	18	25
60A1	6 6.35 7 8 9 9.52 10 11 12 12.7 14	60	75		65	3	M5x12	23	30
60B	6 6.35 7 8 9 9.52 10 11 12 12.7 14	60	85		75	3	M5x12	23	30
60C	6 6.35 7 8 9 9.52 10 11 12 12.7 14	60	90		75	3	M5x12	23	30
70A	6 6.35 7 8 9 9.52 10 11 12 12.7 14	70	85		75	3	M6x15	23	30
70B	6 6.35 7 8 9 9.52 10 11 12 12.7 14	70	90		75	5	M5x12	23	30
73A	6 6.35 7 8 9 9.52 10 11 12 12.7 14	73	98.4		85	3	M5x12	25	32
80A	6 6.35 7 8 9 9.52 10 11 12 12.7 14	80	100		85	3	M6x15	23	30

MP K 060

FM

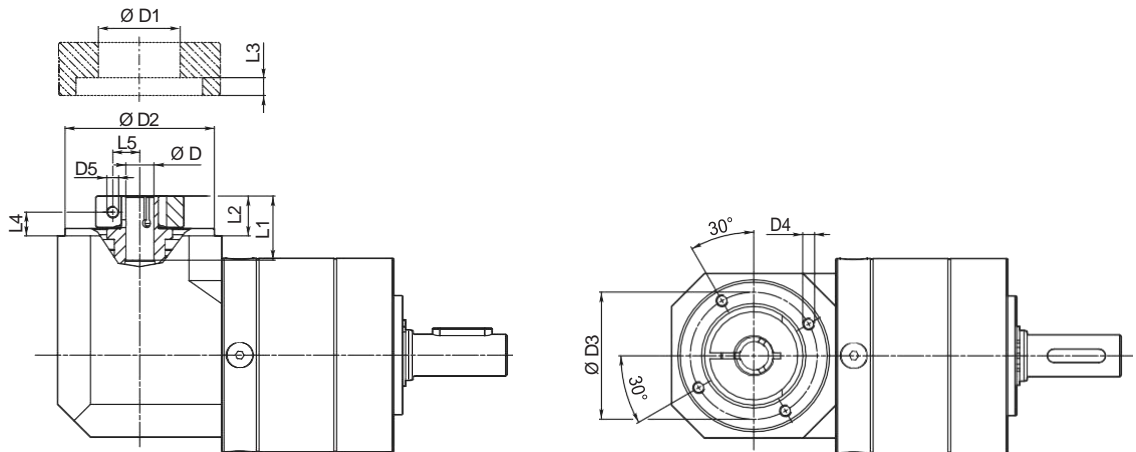

D				D1	D2	D3	D4	D5	L1	L2	L3	L4	L5
6	6.35	7		32.5	50	42.5	M4x8	M4	20.2	13.2	3	8.7	8
8	9	9.52	10	32.5	50	42.5	M4x8	M4	20.2	13.2	3	7.8	9
11	12	12.7		35.5	50	42.5	M4x8	M4	20.5	13.5	3	8.5	11
14				35.5	50	42.5	M4x8	M4	24	17	3	10.2	11.5

i	M _{n 2} [Nm]	M _{a 2} [Nm]	M _{p 2} [Nm]	n ₁ [min ⁻¹]	n _{1 max} [min ⁻¹]	φ _S [arcmin]	φ _R	C _t [Nm/arcmin]	R _{2 max} [N]	A _{2 max} [N]	η %	J _G [kgcm ²]	
												D	D
MP K 060 2 3	18	35	70	3300	4000	15'	10'	3.0	600	700	94	0.20	0.20
MP K 060 2 4	25	40	90	3500	5000	15'	10'	3.0	600	700	94	0.18	0.20
MP K 060 2 5	25	40	90	3500	5000	15'	10'	3.0	600	700	94	0.17	0.19
MP K 060 2 6	25	40	90	3500	5000	15'	10'	3.0	600	700	94	0.17	0.19
MP K 060 2 7	25	40	90	4000	6000	15'	10'	3.0	600	700	94	0.17	0.19
MP K 060 2 10	18	35	70	4000	6000	15'	10'	3.0	600	700	94	0.17	0.18
MP K 060 3 9	18	35	70	3300	4000	15'	10'	2.5	600	700	91	0.20	0.21
MP K 060 3 12	30	45	100	3300	4000	15'	10'	2.5	600	700	91	0.20	0.21
MP K 060 3 15	30	45	100	3300	4000	15'	10'	2.5	600	700	91	0.19	0.21
MP K 060 3 16	30	45	100	3500	5000	15'	10'	2.5	600	700	91	0.18	0.20
MP K 060 3 20	30	45	100	3500	5000	15'	10'	2.5	600	700	91	0.17	0.19
MP K 060 3 25	30	45	100	3500	5000	15'	10'	2.5	600	700	91	0.17	0.18
MP K 060 3 28	30	45	100	4000	6000	15'	10'	2.5	600	700	91	0.17	0.19
MP K 060 3 30	18	35	70	4000	6000	15'	10'	2.5	600	700	91	0.17	0.18
MP K 060 3 35	30	45	100	4000	6000	15'	10'	2.5	600	700	91	0.18	0.19
MP K 060 3 36	25	40	90	3500	5000	15'	10'	2.5	600	700	91	0.18	0.19
MP K 060 3 40	30	45	100	4000	6000	15'	10'	2.5	600	700	91	0.17	0.18
MP K 060 3 50	30	45	100	4000	6000	15'	10'	2.5	600	700	91	0.17	0.18
MP K 060 3 70	30	45	100	4000	6000	15'	10'	2.5	600	700	91	0.17	0.18
MP K 060 3 100	18	35	70	4000	6000	15'	10'	2.5	600	700	91	0.17	0.18
MP K 060 4 48	30	45	100	3500	5000	17'	12'	1.8	600	700	89	0.18	0.20
MP K 060 4 64	30	45	100	3500	5000	17'	12'	1.8	600	700	89	0.18	0.20
MP K 060 4 75	30	45	100	3500	5000	17'	12'	1.8	600	700	89	0.17	0.19
MP K 060 4 80	30	45	100	3500	5000	17'	12'	1.8	600	700	89	0.18	0.20
MP K 060 4 84	30	45	100	4000	6000	17'	12'	1.8	600	700	89	0.17	0.19
MP K 060 4 90	18	35	70	4000	6000	17'	12'	1.8	600	700	89	0.17	0.18
MP K 060 4 120	30	45	100	4000	6000	17'	12'	1.8	600	700	89	0.15	0.17
MP K 060 4 125	30	45	100	3500	5000	17'	12'	1.8	600	700	89	0.17	0.19
MP K 060 4 140	30	45	100	4000	6000	17'	12'	1.8	600	700	89	0.17	0.19
MP K 060 4 150	30	45	100	4000	6000	17'	12'	1.8	600	700	89	0.17	0.18
MP K 060 4 160	30	45	100	4000	6000	17'	12'	1.8	600	700	89	0.17	0.18
MP K 060 4 175	30	45	100	4000	6000	17'	12'	1.8	600	700	89	0.17	0.19
MP K 060 4 200	30	45	100	4000	6000	17'	12'	1.8	600	700	89	0.17	0.18
MP K 060 4 210	30	45	100	4000	6000	17'	12'	1.8	600	700	89	0.17	0.18
MP K 060 4 216	30	45	100	3500	5000	17'	12'	1.8	600	700	89	0.17	0.19
MP K 060 4 250	30	45	100	4000	6000	17'	12'	1.8	600	700	89	0.17	0.18
MP K 060 4 280	30	45	100	4000	6000	17'	12'	1.8	600	700	89	0.17	0.18
MP K 060 4 350	30	45	100	4000	6000	17'	12'	1.8	600	700	89	0.17	0.18
MP K 060 4 400	30	45	100	4000	6000	17'	12'	1.8	600	700	89	0.17	0.18
MP K 060 4 500	30	45	100	4000	6000	17'	12'	1.8	600	700	89	0.17	0.18
MP K 060 4 700	30	45	100	4000	6000	17'	12'	1.8	600	700	89	0.17	0.18
MP K 060 4 1000	18	35	70	4000	6000	17'	12'	1.8	600	700	89	0.17	0.18

MP

Please contact us for different motor adapters and input shaft bore.

MP 080

IS

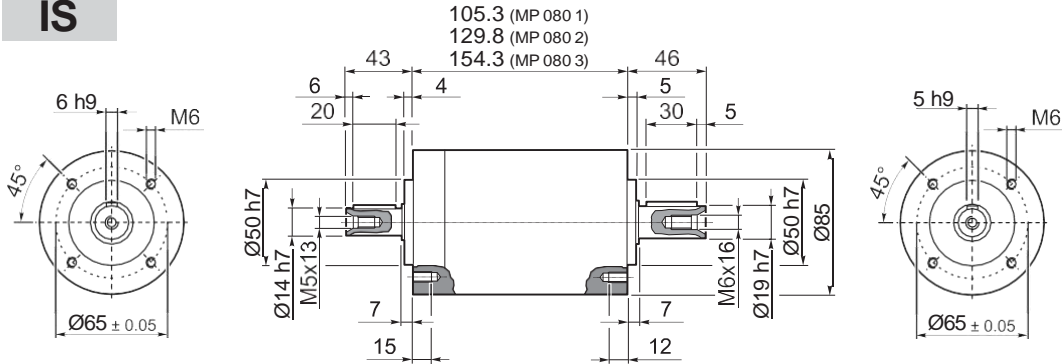

MP 080 1	4.0
MP 080 2	4.6
MP 080 3	5.2

40B1 ... 110B1

MP

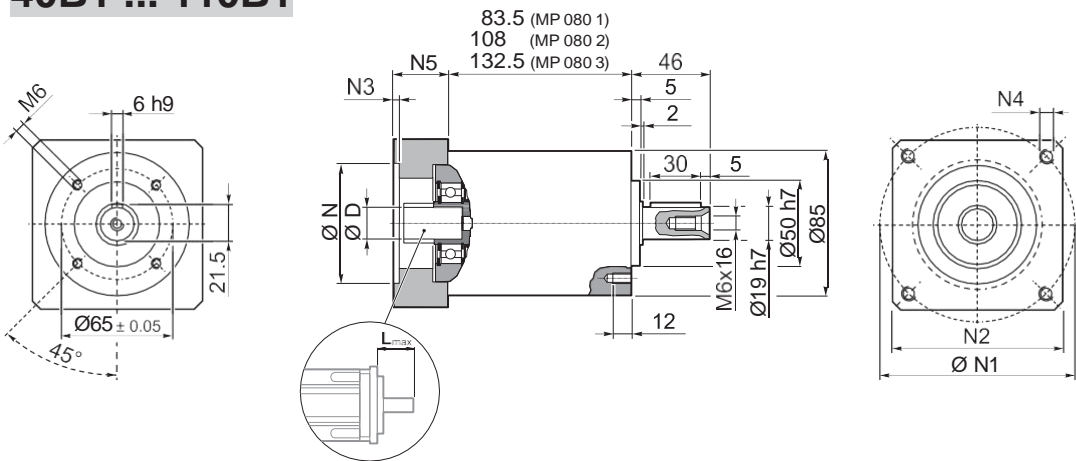

MP 080 1	4.0
MP 080 2	4.6
MP 080 3	5.2

											N	N1	N2	N3	N4	N5	L _{max}		
40B1	8	9	9.52	11	12	12.7	14	-	-	-	-	40	63	80	4	M4x12	34	40	
45A	8	9	9.52	11	12	12.7	-	-	-	-	-	45	63	80	4	M4x12	34	40	
50B1	8	9	9.52	11	12	12.7	14	-	-	-	-	50	65	80	4	M5x16	34	40	
50BH1	8	9	9.52	11	12	12.7	14	-	-	-	-	50	65	80	4	5.5	34	40	
50C1	8	9	9.52	11	12	12.7	14	-	-	-	-	50	70	80	4	M4x10	34	40	
50D	8	9	9.52	11	12	12.7	14	-	-	-	-	50	95	80	4	M6x20	34	40	
55A	8	9	9.52	11	12	12.7	14	15.875	16	17	19	19.05	55.5	125.7	105	4	M6x20	34	40
60A2	8	9	9.52	11	12	12.7	14	-	-	-	-	60	75	80	4	M5x16	34	40	
60AH2	8	9	9.52	11	12	12.7	14	-	-	-	-	60	75	90	4	6.5	34	40	
60B1	8	9	9.52	11	12	12.7	14	15.875	16	-	-	60	85	80	4	M5x16	34	40	
60C1	8	9	9.52	11	12	12.7	14	15.875	16	-	-	60	90	80	4	M5x16	34	40	
70A1	8	9	9.52	11	12	12.7	14	15.875	16	17	19	19.05	70	85	80	4	M6x20	34	40
70AH1	8	9	9.52	11	12	12.7	14	15.875	16	17	19	19.05	70	85	90	4	6.5	34	40
70B1	8	9	9.52	11	12	12.7	14	15.875	16	17	19	19.05	70	90	80	4	M5x16	34	40
73A1	8	9	9.52	11	12	12.7	14	-	-	-	-	73	98.4	85	4	M5x16	34	40	
80A1	8	9	9.52	11	12	12.7	14	15.875	16	17	19	19.05	80	100	90	4	M6x16	34	40
95A	8	9	9.52	11	12	12.7	14	15.875	16	17	19	19.05	95	115	100	4	M8x20	34	40
95B	8	9	9.52	11	12	12.7	14	15.875	16	17	19	19.05	95	130	115	4	M8x20	34	40
110A	8	9	9.52	11	12	12.7	14	15.875	16	17	19	19.05	110	130	115	4	M8x20	34	40
110B	8	9	9.52	11	12	12.7	14	15.875	16	17	19	19.05	110	145	120	6.5	M8x20	44	50
110B1	8	9	9.52	11	12	12.7	14	15.875	16	17	19	19.05	110	145	120	6.5	M8x20	54	60

MP 080

FM

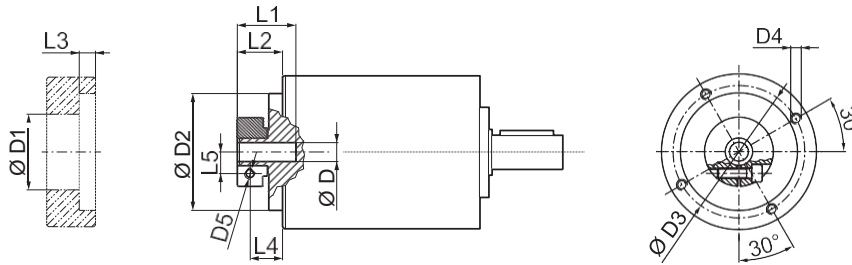

D				D1	D2	D3	D4	D5	L1	L2	L3	L4	L5
8	9	9.52		38	68	76.5	M6x12	M6	32.2	26.3	9.5	19.3	10.5
11	12	12.7		43	68	76.5	M6x12	M6	32.2	26.3	9.5	19.3	12.5
14	15.875	16	17	48	68	76.5	M6x12	M6	32.2	26.3	9.5	19.3	14.5
19	19.05			51	68	76.5	M6x12	M6	32.2	26.3	9.5	19.3	16.5

 i	M _{n 2}	M _{a 2}	M _{p 2}	n ₁	n _{1 max}	φ _S	φ _R	C _t	R _{1 max}	R _{2 max}	A _{2 max}	R _{2 max}	A _{2 max}	η	J _G [kgcm ²]	
	[Nm]	[Nm]	[Nm]	[min ⁻¹]	[min ⁻¹]	[arcmin]		$\frac{Nm}{arcmin}$	[N]	[N]	[N]	[N]	[N]	%	8 ... 12.7	14 ... 19.05
MP 080 1_3	40	80	180	2900	3500	15'	10'	7.0	400	1300	1400	2500	3000	97	0.50	0.59
MP 080 1_4	50	80	200	3100	4500	15'	10'	7.0	400	1300	1400	2500	3000	97	0.34	0.43
MP 080 1_5	50	80	200	3200	4500	15'	10'	7.0	400	1300	1400	2500	3000	97	0.28	0.37
MP 080 1_6	50	80	200	3200	4500	15'	10'	7.0	400	1300	1400	2500	3000	97	0.21	0.30
MP 080 1_7	50	80	200	4000	6000	15'	10'	7.0	400	1300	1400	2500	3000	97	0.23	0.32
MP 080 1_10	40	80	180	4000	6000	15'	10'	7.0	400	1300	1400	2500	3000	97	0.20	0.29
MP 080 2_9	40	80	180	2900	3500	15'	10'	5.9	400	1300	1400	2500	3000	94	0.49	0.58
MP 080 2_12	70	100	250	2900	3500	15'	10'	5.9	400	1300	1400	2500	3000	94	0.47	0.56
MP 080 2_15	70	100	250	2900	3500	15'	10'	5.9	400	1300	1400	2500	3000	94	0.46	0.55
MP 080 2_16	70	100	250	3100	4500	15'	10'	5.9	400	1300	1400	2500	3000	94	0.32	0.41
MP 080 2_20	70	100	250	3200	4500	15'	10'	5.9	400	1300	1400	2500	3000	94	0.27	0.36
MP 080 2_25	70	100	250	3200	4500	15'	10'	5.9	400	1300	1400	2500	3000	94	0.27	0.36
MP 080 2_28	70	100	250	4000	6000	15'	10'	5.9	400	1300	1400	2500	3000	94	0.22	0.31
MP 080 2_30	40	80	180	4000	6000	15'	10'	5.9	400	1300	1400	2500	3000	94	0.20	0.29
MP 080 2_35	70	100	250	4000	6000	15'	10'	5.9	400	1300	1400	2500	3000	94	0.22	0.31
MP 080 2_36	50	80	200	3200	4500	15'	10'	5.9	400	1300	1400	2500	3000	94	0.20	0.29
MP 080 2_40	70	100	250	4000	6000	15'	10'	5.9	400	1300	1400	2500	3000	94	0.20	0.29
MP 080 2_50	70	100	250	4000	6000	15'	10'	5.9	400	1300	1400	2500	3000	94	0.19	0.28
MP 080 2_70	70	100	250	4000	6000	15'	10'	5.9	400	1300	1400	2500	3000	94	0.19	0.28
MP 080 2_100	40	80	180	4000	6000	15'	10'	5.9	400	1300	1400	2500	3000	94	0.19	0.28
MP 080 3_48	70	100	250	3100	4500	17'	12'	5.4	400	1300	1400	2500	3000	91	0.33	0.42
MP 080 3_64	70	100	250	3100	4500	17'	12'	5.4	400	1300	1400	2500	3000	91	0.32	0.41
MP 080 3_75	70	100	250	3200	4500	17'	12'	5.4	400	1300	1400	2500	3000	91	0.27	0.36
MP 080 3_80	70	100	250	3100	4500	17'	12'	5.4	400	1300	1400	2500	3000	91	0.32	0.41
MP 080 3_84	70	100	250	4000	6000	17'	12'	5.4	400	1300	1400	2500	3000	91	0.23	0.32
MP 080 3_90	40	80	180	4000	6000	17'	12'	5.4	400	1300	1400	2500	3000	91	0.20	0.29
MP 080 3_120	70	100	250	4000	6000	17'	12'	5.4	400	1300	1400	2500	3000	91	0.20	0.29
MP 080 3_125	70	100	250	3200	4500	17'	12'	5.4	400	1300	1400	2500	3000	91	0.27	0.36
MP 080 3_140	70	100	250	4000	6000	17'	12'	5.4	400	1300	1400	2500	3000	91	0.22	0.31
MP 080 3_150	70	100	250	4000	6000	17'	12'	5.4	400	1300	1400	2500	3000	91	0.20	0.29
MP 080 3_160	70	100	250	4000	6000	17'	12'	5.4	400	1300	1400	2500	3000	91	0.20	0.29
MP 080 3_175	70	100	250	4000	6000	17'	12'	5.4	400	1300	1400	2500	3000	91	0.22	0.31
MP 080 3_200	70	100	250	4000	6000	17'	12'	5.4	400	1300	1400	2500	3000	91	0.20	0.29
MP 080 3_210	70	100	250	4000	6000	17'	12'	5.4	400	1300	1400	2500	3000	91	0.20	0.29
MP 080 3_216	70	100	250	3200	4500	17'	12'	5.4	400	1300	1400	2500	3000	91	0.20	0.29
MP 080 3_250	70	100	250	4000	6000	17'	12'	5.4	400	1300	1400	2500	3000	91	0.19	0.28
MP 080 3_280	70	100	250	4000	6000	17'	12'	5.4	400	1300	1400	2500	3000	91	0.19	0.28
MP 080 3_350	70	100	250	4000	6000	17'	12'	5.4	400	1300	1400	2500	3000	91	0.19	0.28
MP 080 3_400	70	100	250	4000	6000	17'	12'	5.4	400	1300	1400	2500	3000	91	0.19	0.28
MP 080 3_500	70	100	250	4000	6000	17'	12'	5.4	400	1300	1400	2500	3000	91	0.19	0.28
MP 080 3_700	70	100	250	4000	6000	17'	12'	5.4	400	1300	1400	2500	3000	91	0.19	0.28
MP 080 3_1000	40	80	180	4000	6000	17'	12'	5.4	400	1300	1400	2500	3000	91	0.19	0.28

MP

Please contact us for different motor adapters and input shaft bore.

MP G 080

40B1 ... 110B1

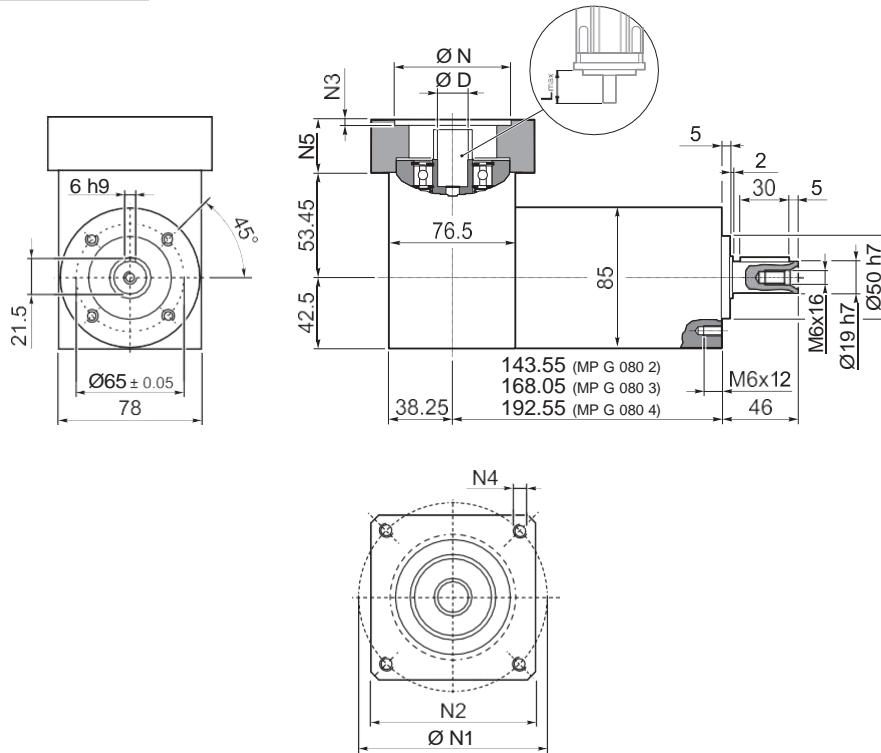

	MP G 080 2	5.2
	MP G 080 3	5.8
	MP G 080 4	6.4

MP

												N	N1	N2	N3	N4	N5	L _{max}	
40B1	8	9	9.52	11	12	12.7	14	-	-	-	-	-	40	63	80	4	M4x12	34	40
45A	8	9	9.52	11	12	12.7	-	-	-	-	-	-	45	63	80	4	M4x12	34	40
50B1	8	9	9.52	11	12	12.7	14	-	-	-	-	-	50	65	80	4	M5x16	34	40
50BH1	8	9	9.52	11	12	12.7	14	-	-	-	-	-	50	65	80	4	5.5	34	40
50C1	8	9	9.52	11	12	12.7	14	-	-	-	-	-	50	70	80	4	M4x10	34	40
50D	8	9	9.52	11	12	12.7	14	-	-	-	-	-	50	95	80	4	M6x20	34	40
55A	8	9	9.52	11	12	12.7	14	15.875	16	17	19	19.05	55.5	125.7	105	4	M6x20	34	40
60A2	8	9	9.52	11	12	12.7	14	-	-	-	-	-	60	75	80	4	M5x16	34	40
60AH2	8	9	9.52	11	12	12.7	14	-	-	-	-	-	60	75	90	4	6.5	34	40
60B1	8	9	9.52	11	12	12.7	14	15.875	16	-	-	-	60	85	80	4	M5x16	34	40
60C1	8	9	9.52	11	12	12.7	14	15.875	16	-	-	-	60	90	80	4	M5x16	34	40
70A1	8	9	9.52	11	12	12.7	14	15.875	16	17	19	19.05	70	85	80	4	M6x20	34	40
70AH1	8	9	9.52	11	12	12.7	14	15.875	16	17	19	19.05	70	85	90	4	6.5	34	40
70B1	8	9	9.52	11	12	12.7	14	15.875	16	17	19	19.05	70	90	80	4	M5x16	34	40
73A1	8	9	9.52	11	12	12.7	14	-	-	-	-	-	73	98.4	85	4	M5x16	34	40
80A1	8	9	9.52	11	12	12.7	14	15.875	16	17	19	19.05	80	100	90	4	M6x16	34	40
95A	8	9	9.52	11	12	12.7	14	15.875	16	17	19	19.05	95	115	100	4	M8x20	34	40
95B	8	9	9.52	11	12	12.7	14	15.875	16	17	19	19.05	95	130	115	4	M8x20	34	40
110A	8	9	9.52	11	12	12.7	14	15.875	16	17	19	19.05	110	130	115	4	M8x20	34	40
110B	8	9	9.52	11	12	12.7	14	15.875	16	17	19	19.05	110	145	120	6.5	M8x20	44	50
110B1	8	9	9.52	11	12	12.7	14	15.875	16	17	19	19.05	110	145	120	6.5	M8x20	54	60

MP G 080

FM

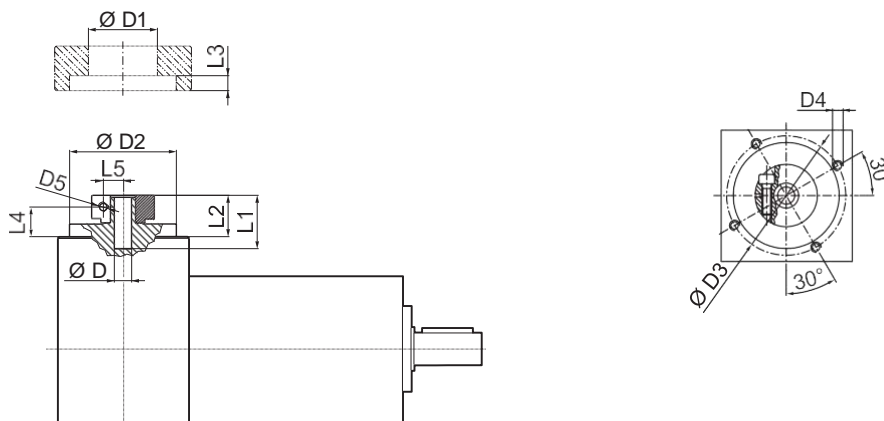

D				D1	D2	D3	D4	D5	L1	L2	L3	L4	L5
8	9	9.52		38	68	76.5	M6x12	M6	32.2	26.3	9.5	19.3	10.5
11	12	12.7		43	68	76.5	M6x12	M6	32.2	26.3	9.5	19.3	12.5
14	15.875	16	17	48	68	76.5	M6x12	M6	32.2	26.3	9.5	19.3	14.5
19	19.05			51	68	76.5	M6x12	M6	32.2	26.3	9.5	19.3	16.5

 i	M _{n 2}	M _{a 2}	M _{p 2}	n ₁	n _{1 max}	φ _S	φ _R	C _t	SB		HB		η	J _G [kgcm ²]	
	[Nm]	[Nm]	[Nm]	[min ⁻¹]	[min ⁻¹]	[arcmin]		$\frac{Nm}{arcmin}$	R _{2 max} [N]	A _{2 max} [N]	R _{2 max} [N]	A _{2 max} [N]		%	8 ... 12.7
MP G 080 2 3	40	80	180	2900	3500	15'	10'	7.0	1300	1400	2500	3000	94	0.67	0.79
MP G 080 2 4	50	80	200	3100	4500	15'	10'	7.0	1300	1400	2500	3000	94	0.62	0.75
MP G 080 2 5	50	80	200	3200	4500	15'	10'	7.0	1300	1400	2500	3000	94	0.61	0.74
MP G 080 2 6	50	80	200	3200	4500	15'	10'	7.0	1300	1400	2500	3000	94	0.58	0.71
MP G 080 2 7	50	80	200	4000	6000	15'	10'	7.0	1300	1400	2500	3000	94	0.60	0.73
MP G 080 2 10	40	80	180	4000	6000	15'	10'	7.0	1300	1400	2500	3000	94	0.60	0.72
MP G 080 3 9	40	80	180	2900	3500	15'	10'	5.9	1300	1400	2500	3000	91	0.66	0.78
MP G 080 3 12	70	100	250	2900	3500	15'	10'	5.9	1300	1400	2500	3000	91	0.75	0.87
MP G 080 3 15	70	100	250	2900	3500	15'	10'	5.9	1300	1400	2500	3000	91	0.74	0.87
MP G 080 3 16	70	100	250	3100	4500	15'	10'	5.9	1300	1400	2500	3000	91	0.60	0.73
MP G 080 3 20	70	100	250	3200	4500	15'	10'	5.9	1300	1400	2500	3000	91	0.60	0.73
MP G 080 3 25	70	100	250	3200	4500	15'	10'	5.9	1300	1400	2500	3000	91	0.64	0.76
MP G 080 3 28	70	100	250	4000	6000	15'	10'	5.9	1300	1400	2500	3000	91	0.59	0.72
MP G 080 3 30	40	80	180	4000	6000	15'	10'	5.9	1300	1400	2500	3000	91	0.60	0.72
MP G 080 3 35	70	100	250	4000	6000	15'	10'	5.9	1300	1400	2500	3000	91	0.61	0.74
MP G 080 3 36	50	80	200	3200	4500	15'	10'	5.9	1300	1400	2500	3000	91	0.57	0.70
MP G 080 3 40	70	100	250	4000	6000	15'	10'	5.9	1300	1400	2500	3000	91	0.60	0.72
MP G 080 3 50	70	100	250	4000	6000	15'	10'	5.9	1300	1400	2500	3000	91	0.59	0.71
MP G 080 3 70	70	100	250	4000	6000	15'	10'	5.9	1300	1400	2500	3000	91	0.59	0.71
MP G 080 3 100	40	80	180	4000	6000	15'	10'	5.9	1300	1400	2500	3000	91	0.59	0.71
MP G 080 4 48	70	100	250	3100	4500	17'	12'	5.4	1300	1400	2500	3000	89	0.61	0.75
MP G 080 4 64	70	100	250	3100	4500	17'	12'	5.4	1300	1400	2500	3000	89	0.60	0.73
MP G 080 4 75	70	100	250	3200	4500	17'	12'	5.4	1300	1400	2500	3000	89	0.60	0.73
MP G 080 4 80	70	100	250	3100	4500	17'	12'	5.4	1300	1400	2500	3000	89	0.60	0.73
MP G 080 4 84	70	100	250	4000	6000	17'	12'	5.4	1300	1400	2500	3000	89	0.60	0.73
MP G 080 4 90	40	80	180	4000	6000	17'	12'	5.4	1300	1400	2500	3000	89	0.60	0.72
MP G 080 4 120	70	100	250	4000	6000	17'	12'	5.4	1300	1400	2500	3000	89	0.60	0.72
MP G 080 4 125	70	100	250	3200	4500	17'	12'	5.4	1300	1400	2500	3000	89	0.60	0.73
MP G 080 4 140	70	100	250	4000	6000	17'	12'	5.4	1300	1400	2500	3000	89	0.59	0.72
MP G 080 4 150	70	100	250	4000	6000	17'	12'	5.4	1300	1400	2500	3000	89	0.60	0.72
MP G 080 4 160	70	100	250	4000	6000	17'	12'	5.4	1300	1400	2500	3000	89	0.60	0.72
MP G 080 4 175	70	100	250	4000	6000	17'	12'	5.4	1300	1400	2500	3000	89	0.59	0.72
MP G 080 4 200	70	100	250	4000	6000	17'	12'	5.4	1300	1400	2500	3000	89	0.60	0.72
MP G 080 4 210	70	100	250	4000	6000	17'	12'	5.4	1300	1400	2500	3000	89	0.60	0.72
MP G 080 4 216	70	100	250	3200	4500	17'	12'	5.4	1300	1400	2500	3000	89	0.57	0.70
MP G 080 4 250	70	100	250	4000	6000	17'	12'	5.4	1300	1400	2500	3000	89	0.59	0.71
MP G 080 4 280	70	100	250	4000	6000	17'	12'	5.4	1300	1400	2500	3000	89	0.59	0.71
MP G 080 4 350	70	100	250	4000	6000	17'	12'	5.4	1300	1400	2500	3000	89	0.59	0.71
MP G 080 4 400	70	100	250	4000	6000	17'	12'	5.4	1300	1400	2500	3000	89	0.59	0.71
MP G 080 4 500	70	100	250	4000	6000	17'	12'	5.4	1300	1400	2500	3000	89	0.59	0.71
MP G 080 4 700	70	100	250	4000	6000	17'	12'	5.4	1300	1400	2500	3000	89	0.59	0.71
MP G 080 4 1000	40	80	180	4000	6000	17'	12'	5.4	1300	1400	2500	3000	89	0.59	0.71

MP

Please contact us for different motor adapters and input shaft bore.

MP MB 080

40B1 ... 110B1

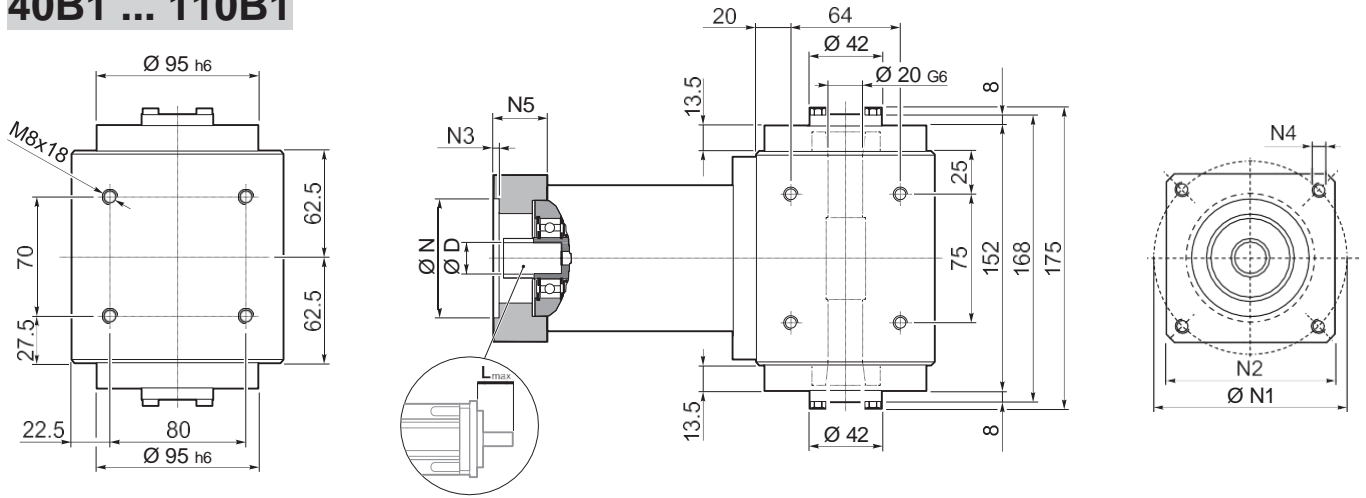

149.5 (MP MB 080 2)
174 (MP MB 080 3)
198.5 (MP MB 080 4)

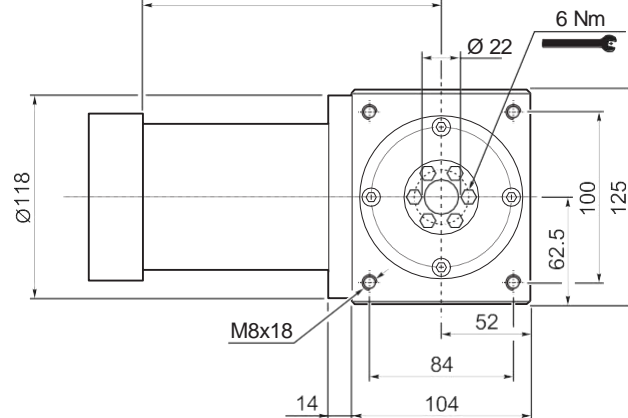

MP MB 080 2	9.5
MP MB 080 3	10.5
MP MB 080 4	11.5

MP

												N	N1	N2	N3	N4	N5	L _{max}	
40B1	8	9	9.52	11	12	12.7	14	-	-	-	-	-	40	63	80	4	M4x12	34	40
45A	8	9	9.52	11	12	12.7	-	-	-	-	-	-	45	63	80	4	M4x12	34	40
50B1	8	9	9.52	11	12	12.7	14	-	-	-	-	-	50	65	80	4	M5x16	34	40
50BH1	8	9	9.52	11	12	12.7	14	-	-	-	-	-	50	65	80	4	5.5	34	40
50C1	8	9	9.52	11	12	12.7	14	-	-	-	-	-	50	70	80	4	M4x10	34	40
50D	8	9	9.52	11	12	12.7	14	-	-	-	-	-	50	95	80	4	M6x20	34	40
55A	8	9	9.52	11	12	12.7	14	15.875	16	17	19	19.05	55.5	125.7	105	4	M6x20	34	40
60A2	8	9	9.52	11	12	12.7	14	-	-	-	-	-	60	75	80	4	M5x16	34	40
60AH2	8	9	9.52	11	12	12.7	14	-	-	-	-	-	60	75	90	4	6.5	34	40
60B1	8	9	9.52	11	12	12.7	14	15.875	16	-	-	-	60	85	80	4	M5x16	34	40
60C1	8	9	9.52	11	12	12.7	14	15.875	16	-	-	-	60	90	80	4	M5x16	34	40
70A1	8	9	9.52	11	12	12.7	14	15.875	16	17	19	19.05	70	85	80	4	M6x20	34	40
70AH1	8	9	9.52	11	12	12.7	14	15.875	16	17	19	19.05	70	85	90	4	6.5	34	40
70B1	8	9	9.52	11	12	12.7	14	15.875	16	17	19	19.05	70	90	80	4	M5x16	34	40
73A1	8	9	9.52	11	12	12.7	14	-	-	-	-	-	73	98.4	85	4	M5x16	34	40
80A1	8	9	9.52	11	12	12.7	14	15.875	16	17	19	19.05	80	100	90	4	M6x16	34	40
95A	8	9	9.52	11	12	12.7	14	15.875	16	17	19	19.05	95	115	100	4	M8x20	34	40
95B	8	9	9.52	11	12	12.7	14	15.875	16	17	19	19.05	95	130	115	4	M8x20	34	40
110A	8	9	9.52	11	12	12.7	14	15.875	16	17	19	19.05	110	130	115	4	M8x20	34	40
110B	8	9	9.52	11	12	12.7	14	15.875	16	17	19	19.05	110	145	120	6.5	M8x20	44	50
110B1	8	9	9.52	11	12	12.7	14	15.875	16	17	19	19.05	110	145	120	6.5	M8x20	54	60

MP MB 080

FM

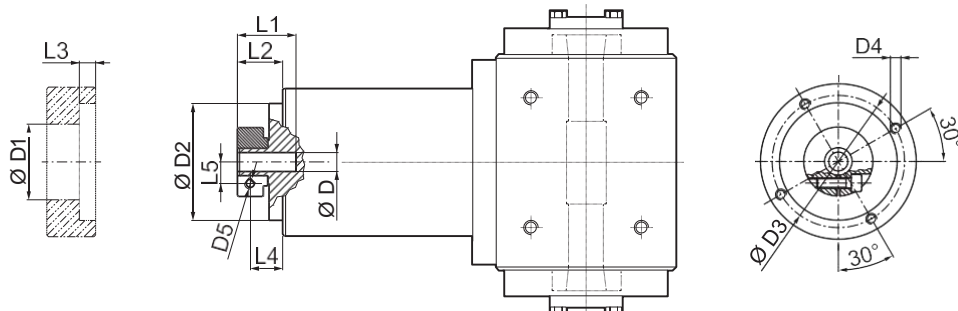

D				D1	D2	D3	D4	D5	L1	L2	L3	L4	L5
8	9	9.52		38	68	76.5	M6x12	M6	32.2	26.3	9.5	19.3	10.5
11	12	12.7		43	68	76.5	M6x12	M6	32.2	26.3	9.5	19.3	12.5
14	15.875	16	17	48	68	76.5	M6x12	M6	32.2	26.3	9.5	19.3	14.5
19	19.05			51	68	76.5	M6x12	M6	32.2	26.3	9.5	19.3	16.5

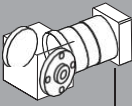
 i	M _{n 2}	M _{a 2}	M _{p 2}	n ₁	n _{1 max}	φ _S	φ _R	C _t	η	J _G [kgcm ²]	
	[Nm]	[Nm]	[Nm]	[min ⁻¹]	[min ⁻¹]	[arcmin]	[arcmin]	$\frac{Nm}{arcmin}$	%	8 ... 12.7	14 ... 19.05
MP MB 080 2 3	40	80	180	2900	3500	15'	10'	7.0	94	0.50	0.59
MP MB 080 2 4	50	80	200	3100	4500	15'	10'	7.0	94	0.34	0.43
MP MB 080 2 5	50	80	200	3200	4500	15'	10'	7.0	94	0.28	0.37
MP MB 080 2 6	50	80	200	3200	4500	15'	10'	7.0	94	0.21	0.30
MP MB 080 2 7	50	80	200	4000	6000	15'	10'	7.0	94	0.23	0.32
MP MB 080 2 10	40	80	180	4000	6000	15'	10'	7.0	94	0.20	0.29
MP MB 080 3 9	40	80	180	2900	3500	15'	10'	5.9	91	0.49	0.58
MP MB 080 3 12	70	100	250	2900	3500	15'	10'	5.9	91	0.47	0.56
MP MB 080 3 15	70	100	250	2900	3500	15'	10'	5.9	91	0.46	0.55
MP MB 080 3 16	70	100	250	3100	4500	15'	10'	5.9	91	0.32	0.41
MP MB 080 3 20	70	100	250	3200	4500	15'	10'	5.9	91	0.27	0.36
MP MB 080 3 25	70	100	250	3200	4500	15'	10'	5.9	91	0.27	0.36
MP MB 080 3 28	70	100	250	4000	6000	15'	10'	5.9	91	0.22	0.31
MP MB 080 3 30	40	80	180	4000	6000	15'	10'	5.9	91	0.20	0.29
MP MB 080 3 35	70	100	250	4000	6000	15'	10'	5.9	91	0.22	0.31
MP MB 080 3 36	50	80	200	3200	4500	15'	10'	5.9	91	0.20	0.29
MP MB 080 3 40	70	100	250	4000	6000	15'	10'	5.9	91	0.20	0.29
MP MB 080 3 50	70	100	250	4000	6000	15'	10'	5.9	91	0.19	0.28
MP MB 080 3 70	70	100	250	4000	6000	15'	10'	5.9	91	0.19	0.28
MP MB 080 3 100	40	80	180	4000	6000	15'	10'	5.9	91	0.19	0.28
MP MB 080 4 48	70	100	250	3100	4500	17'	12'	5.4	89	0.33	0.42
MP MB 080 4 64	70	100	250	3100	4500	17'	12'	5.4	89	0.32	0.41
MP MB 080 4 75	70	100	250	3200	4500	17'	12'	5.4	89	0.27	0.36
MP MB 080 4 80	70	100	250	3100	4500	17'	12'	5.4	89	0.32	0.41
MP MB 080 4 84	70	100	250	4000	6000	17'	12'	5.4	89	0.23	0.32
MP MB 080 4 90	40	80	180	4000	6000	17'	12'	5.4	89	0.20	0.29
MP MB 080 4 120	70	100	250	4000	6000	17'	12'	5.4	89	0.20	0.29
MP MB 080 4 125	70	100	250	3200	4500	17'	12'	5.4	89	0.27	0.36
MP MB 080 4 140	70	100	250	4000	6000	17'	12'	5.4	89	0.22	0.31
MP MB 080 4 150	70	100	250	4000	6000	17'	12'	5.4	89	0.20	0.29
MP MB 080 4 160	70	100	250	4000	6000	17'	12'	5.4	89	0.20	0.29
MP MB 080 4 175	70	100	250	4000	6000	17'	12'	5.4	89	0.22	0.31
MP MB 080 4 200	70	100	250	4000	6000	17'	12'	5.4	89	0.20	0.29
MP MB 080 4 210	70	100	250	4000	6000	17'	12'	5.4	89	0.20	0.29
MP MB 080 4 216	70	100	250	3200	4500	17'	12'	5.4	89	0.20	0.29
MP MB 080 4 250	70	100	250	4000	6000	17'	12'	5.4	89	0.19	0.28
MP MB 080 4 280	70	100	250	4000	6000	17'	12'	5.4	89	0.19	0.28
MP MB 080 4 350	70	100	250	4000	6000	17'	12'	5.4	89	0.19	0.28
MP MB 080 4 400	70	100	250	4000	6000	17'	12'	5.4	89	0.19	0.28
MP MB 080 4 500	70	100	250	4000	6000	17'	12'	5.4	89	0.19	0.28
MP MB 080 4 700	70	100	250	4000	6000	17'	12'	5.4	89	0.19	0.28
MP MB 080 4 1000	40	80	180	4000	6000	17'	12'	5.4	89	0.19	0.28

MP

Please contact us for different motor adapters and input shaft bore.

MP 105

IS

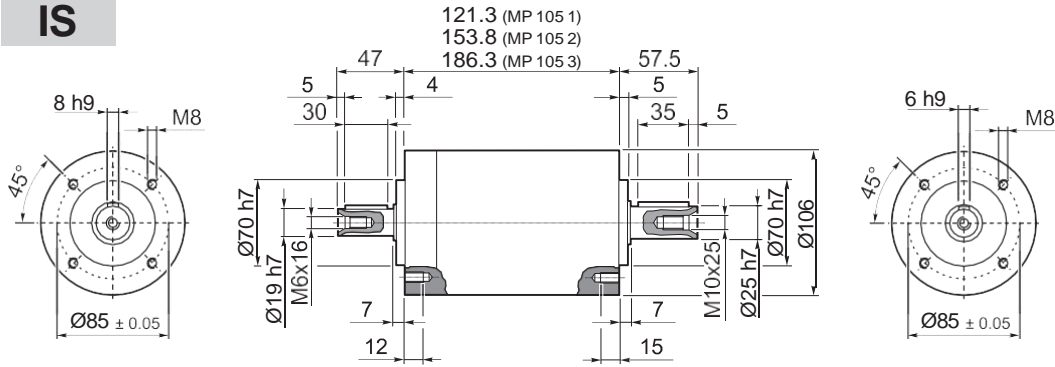

MP 105 1	6.5
MP 105 2	8.5
MP 105 3	10.5

50D ... 130A1

MP

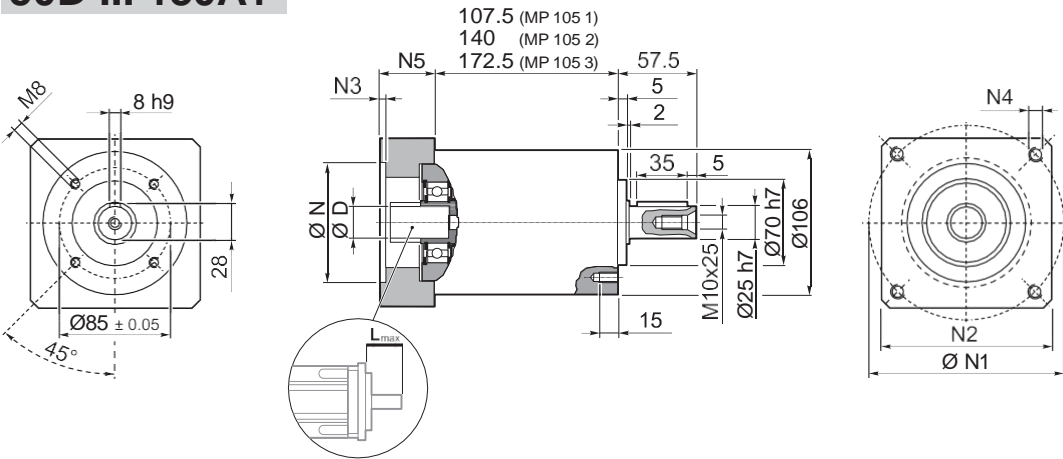

MP 105 1	6.5
MP 105 2	8.5
MP 105 3	10.5

											N	N1	N2	N3	N4	N5	L _{max}	
50D	11	12	12.7	14	15	15.875	16	19	-	-	-	50	95	100	5	M6x14	28	40
55A	11	12	12.7	14	15	15.875	16	19	-	-	-	55	125.7	105	5	M6x16	28	40
60A2	11	12	12.7	14	15	15.875	16	19	-	-	-	60	75	100	6.5	M5x14	28	40
60AH2	11	12	12.7	14	15	15.875	16	19	-	-	-	60	75	100	4	6.5	33	40
60B1	11	12	12.7	14	15	15.875	16	19	-	-	-	60	85	100	6.5	M5x14	28	40
70A1	11	12	12.7	14	15	15.875	16	19	-	-	-	70	85	100	6.5	M6x14	28	40
70AH1	11	12	12.7	14	15	15.875	16	19	-	-	-	70	85	100	4	6.5	33	40
70B1	11	12	12.7	14	15	15.875	16	19	-	-	-	70	90	100	6.5	M5x12	28	40
80A1	11	12	12.7	14	15	15.875	16	19	-	-	-	80	100	100	6.5	M6x16	28	40
80AH1	11	12	12.7	14	15	15.875	16	19	-	-	-	80	100	100	4	6.5	33	40
95A	11	12	12.7	14	15	15.875	16	19	-	-	-	95	115	100	6.5	M8x18	28	40
95A1	11	12	12.7	14	15	15.875	16	19	22	24	-	95	115	100	6.5	M8x18	38	50
95B	11	12	12.7	14	15	15.875	16	19	-	-	-	95	130	115	6.5	M8x18	28	40
110A	11	12	12.7	14	15	15.875	16	19	-	-	-	110	130	115	6.5	M8x18	28	40
110A1	11	12	12.7	14	15	15.875	16	19	22	24	-	110	130	115	6.5	M8x20	38	50
110B	11	12	12.7	14	15	15.875	16	19	22	24	-	110	145	120	6.5	M8x20	38	50
110B1	11	12	12.7	14	15	15.875	16	19	22	24	28	110	145	120	6.5	M8x20	48	60
130A	11	12	12.7	14	15	15.875	16	19	22	24	-	130	165	140	6.5	M10x20	38	50
130A1	11	12	12.7	14	15	15.875	16	19	22	24	28	130	165	140	6.5	M10x25	48	60

MP 105

FM

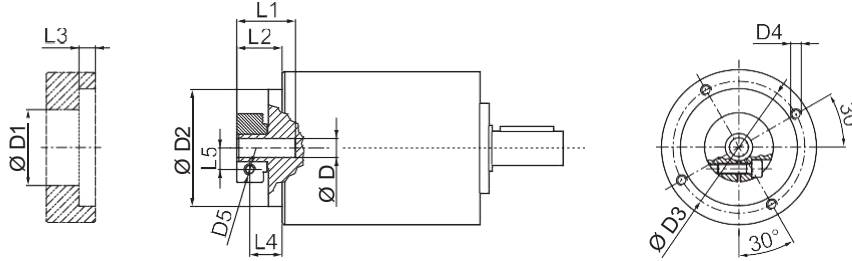

D				D1	D2	D3	D4	D5	L1	L2	L3	L4	L5
11	12	12.7		43	90	98	M6x15	M6	31.5	19.5	7.6	12	12.5
14	15	15.875	16	48	90	98	M6x15	M6	31.5	19.5	7.6	12	14.5
19				51	90	98	M6x15	M6	31.5	19.5	7.6	12	16.5
22	24			56.5	90	98	M6x15	M6	35	23	7.6	12	19
28				67	90	98	M6x15	M8	35	23	7.6	14	22.5
32				71	90	98	M6x15	M8	37	25	7.6	16	24.5

	i	M _{n2}	M _{a2}	M _{p2}	n ₁	n _{1 max}	φ _S	φ _R	C _t	R _{1 max}	SB		HB		η	J _G [kgcm ²]			
		[Nm]	[Nm]	[Nm]	[min ⁻¹]	[min ⁻¹]	[arcmin]	[Nm/arcmin]	[N]	R _{2 max}	A _{2 max}	R _{2 max}	A _{2 max}	%					
											[N]	[N]	[N]	[N]		[N]	11 ... 12.7	14 ... 19	22 - 24
MP 105 1_3		100	180	360	2500	3500	15'	10'	22.0	600	1500	1600	3800	4000	97	1.70	1.78	2.22	2.59
MP 105 1_4		140	210	450	2800	4500	15'	10'	22.0	600	1500	1600	3800	4000	97	0.99	1.06	1.51	1.87
MP 105 1_5		140	210	450	3000	4500	15'	10'	22.0	600	1500	1600	3800	4000	97	0.72	0.79	1.23	1.60
MP 105 1_6		140	210	450	3000	4500	15'	10'	22.0	600	1500	1600	3800	4000	97	0.36	0.43	0.88	1.24
MP 105 1_7		140	210	450	3500	5000	15'	10'	22.0	600	1500	1600	3800	4000	97	0.47	0.55	0.99	1.35
MP 105 1_10		100	180	360	3500	5000	15'	10'	22.0	600	1500	1600	3800	4000	97	0.33	0.41	0.85	1.21
MP 105 2_9		100	180	360	2500	3500	15'	10'	20.5	600	1500	1600	3800	4000	94	1.58	1.63	2.07	2.44
MP 105 2_12		170	250	600	2500	3500	15'	10'	20.5	600	1500	1600	3800	4000	94	1.52	1.59	2.03	2.40
MP 105 2_15		170	250	600	2500	3500	15'	10'	20.5	600	1500	1600	3800	4000	94	1.47	1.55	1.99	2.36
MP 105 2_16		170	250	600	2800	4500	15'	10'	20.5	600	1500	1600	3800	4000	94	0.87	0.95	1.39	1.76
MP 105 2_20		170	250	600	3000	4500	15'	10'	20.5	600	1500	1600	3800	4000	94	0.86	0.93	1.37	1.74
MP 105 2_25		170	250	600	3000	4500	15'	10'	20.5	600	1500	1600	3800	4000	94	0.63	0.71	1.15	1.51
MP 105 2_28		170	250	600	3500	5000	15'	10'	20.5	600	1500	1600	3800	4000	94	0.43	0.51	0.95	1.32
MP 105 2_30		100	180	360	3500	5000	15'	10'	20.5	600	1500	1600	3800	4000	94	0.32	0.40	0.84	1.20
MP 105 2_35		170	250	600	3500	5000	15'	10'	20.5	600	1500	1600	3800	4000	94	0.43	0.50	0.95	1.31
MP 105 2_36		140	210	450	3000	4500	15'	10'	20.5	600	1500	1600	3800	4000	94	0.32	0.39	0.84	1.20
MP 105 2_40		170	250	600	3500	5000	15'	10'	20.5	600	1500	1600	3800	4000	94	0.31	0.39	0.83	1.20
MP 105 2_50		170	250	600	3500	5000	15'	10'	20.5	600	1500	1600	3800	4000	94	0.31	0.39	0.83	1.19
MP 105 2_70		170	250	600	3500	5000	15'	10'	20.5	600	1500	1600	3800	4000	94	0.31	0.38	0.83	1.19
MP 105 2_100		100	180	360	3500	5000	15'	10'	20.5	600	1500	1600	3800	4000	94	0.31	0.38	0.83	1.19
MP 105 3_48		170	250	600	2800	4500	17'	12'	17.5	600	1500	1600	3800	4000	91	0.91	0.98	1.42	1.79
MP 105 3_64		170	250	600	2800	4500	17'	12'	17.5	600	1500	1600	3800	4000	91	0.87	0.94	1.38	1.75
MP 105 3_75		170	250	600	3000	4500	17'	12'	17.5	600	1500	1600	3800	4000	91	0.66	0.74	1.18	1.55
MP 105 3_80		170	250	600	2800	4500	17'	12'	17.5	600	1500	1600	3800	4000	91	0.86	0.94	1.38	1.75
MP 105 3_84		170	250	600	3500	5000	17'	12'	17.5	600	1500	1600	3800	4000	91	0.44	0.52	0.96	1.33
MP 105 3_90		100	180	360	3500	5000	17'	12'	17.5	600	1500	1600	3800	4000	91	0.32	0.39	0.84	1.20
MP 105 3_120		170	250	600	3500	5000	17'	12'	17.5	600	1500	1600	3800	4000	91	0.32	0.39	0.84	1.20
MP 105 3_125		170	250	600	3000	4500	17'	12'	17.5	600	1500	1600	3800	4000	91	0.63	0.70	1.15	1.51
MP 105 3_140		170	250	600	3500	5000	17'	12'	17.5	600	1500	1600	3800	4000	91	0.43	0.51	0.95	1.32
MP 105 3_150		170	250	600	3500	5000	17'	12'	17.5	600	1500	1600	3800	4000	91	0.32	0.39	0.84	1.20
MP 105 3_160		170	250	600	3500	5000	17'	12'	17.5	600	1500	1600	3800	4000	91	0.31	0.39	0.83	1.21
MP 105 3_175		170	250	600	3500	5000	17'	12'	17.5	600	1500	1600	3800	4000	91	0.43	0.50	0.95	1.31
MP 105 3_200		170	250	600	3500	5000	17'	12'	17.5	600	1500	1600	3800	4000	91	0.31	0.39	0.83	1.20
MP 105 3_210		170	250	600	3500	5000	17'	12'	17.5	600	1500	1600	3800	4000	91	0.32	0.39	0.84	1.20
MP 105 3_216		170	250	600	3000	4500	17'	12'	17.5	600	1500	1600	3800	4000	91	0.31	0.39	0.83	1.20
MP 105 3_250		170	250	600	3500	5000	17'	12'	17.5	600	1500	1600	3800	4000	91	0.31	0.39	0.83	1.19
MP 105 3_280		170	250	600	3500	5000	17'	12'	17.5	600	1500	1600	3800	4000	91	0.31	0.38	0.83	1.19
MP 105 3_350		170	250	600	3500	5000	17'	12'	17.5	600	1500	1600	3800	4000	91	0.31	0.38	0.83	1.19
MP 105 3_400		170	250	600	3500	5000	17'	12'	17.5	600	1500	1600	3800	4000	91	0.31	0.38	0.83	1.19
MP 105 3_500		170	250	600	3500	5000	17'	12'	17.5	600	1500	1600	3800	4000	91	0.31	0.38	0.83	1.19
MP 105 3_700		170	250	600	3500	5000	17'	12'	17.5	600	1500	1600	3800	4000	91	0.31	0.38	0.83	1.19
MP 105 3_1000		100	180	360	3500	5000	17'	12'	17.5	600	1500	1600	3800	4000	91	0.31	0.38	0.83	1.19

MP

Please contact us for different motor adapters and input shaft bore.

MP G 105

50D ... 130A1

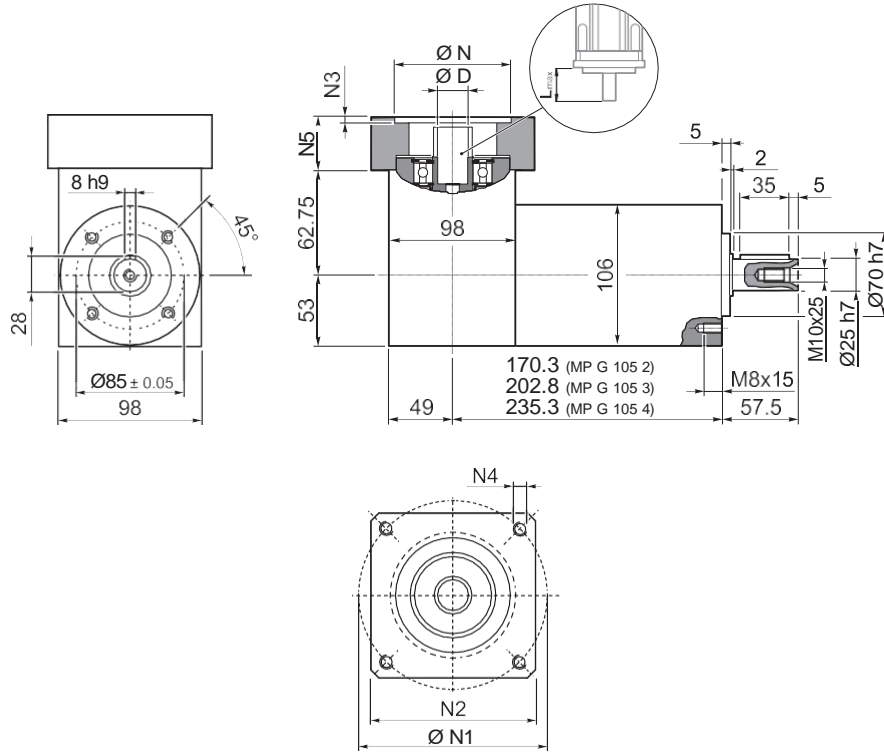

MP G 105 2	8.5
MP G 105 3	10.5
MP G 105 4	12.5

MP

												N	N1	N2	N3	N4	N5	L _{max}	
50D	11	12	12.7	14	15	15.875	16	19	-	-	-	-	50	95	100	5	M6x14	28	40
55A	11	12	12.7	14	15	15.875	16	19	-	-	-	-	55	125.7	105	5	M6x16	28	40
60A2	11	12	12.7	14	15	15.875	16	19	-	-	-	-	60	75	100	6.5	M5x14	28	40
60AH2	11	12	12.7	14	15	15.875	16	19	-	-	-	-	60	75	100	4	6.5	33	40
60B1	11	12	12.7	14	15	15.875	16	19	-	-	-	-	60	85	100	6.5	M5x14	28	40
70A1	11	12	12.7	14	15	15.875	16	19	-	-	-	-	70	85	100	6.5	M6x14	28	40
70AH1	11	12	12.7	14	15	15.875	16	19	-	-	-	-	70	85	100	4	6.5	33	40
70B1	11	12	12.7	14	15	15.875	16	19	-	-	-	-	70	90	100	6.5	M5x12	28	40
80A1	11	12	12.7	14	15	15.875	16	19	-	-	-	-	80	100	100	6.5	M6x16	28	40
80AH1	11	12	12.7	14	15	15.875	16	19	-	-	-	-	80	100	100	4	6.5	33	40
95A	11	12	12.7	14	15	15.875	16	19	-	-	-	-	95	115	100	6.5	M8x18	28	40
95A1	11	12	12.7	14	15	15.875	16	19	22	24	-	-	95	115	100	6.5	M8x18	38	50
95B	11	12	12.7	14	15	15.875	16	19	-	-	-	-	95	130	115	6.5	M8x18	28	40
110A	11	12	12.7	14	15	15.875	16	19	-	-	-	-	110	130	115	6.5	M8x18	28	40
110A1	11	12	12.7	14	15	15.875	16	19	22	24	-	-	110	130	115	6.5	M8x20	38	50
110B	11	12	12.7	14	15	15.875	16	19	22	24	-	-	110	145	120	6.5	M8x20	38	50
110B1	11	12	12.7	14	15	15.875	16	19	22	24	28	-	110	145	120	6.5	M8x20	48	60
130A	11	12	12.7	14	15	15.875	16	19	22	24	-	-	130	165	140	6.5	M10x20	38	50
130A1	11	12	12.7	14	15	15.875	16	19	22	24	28	32	130	165	140	6.5	M10x25	48	60

MP G 105

FM

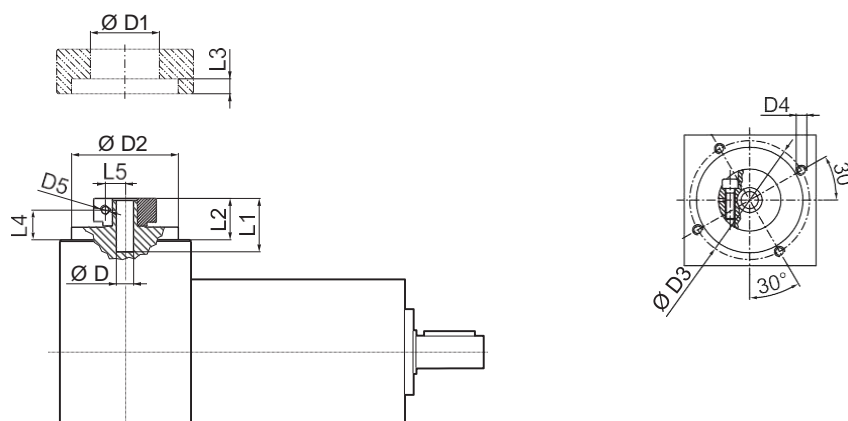

D				D1	D2	D3	D4	D5	L1	L2	L3	L4	L5
11	12	12.7		43	90	98	M6x15	M6	31.5	19.5	7.6	12	12.5
14	15	15.875	16	48	90	98	M6x15	M6	31.5	19.5	7.6	12	14.5
19				51	90	98	M6x15	M6	31.5	19.5	7.6	12	16.5
22	24			56.5	90	98	M6x15	M6	35	23	7.6	12	19
28				67	90	98	M6x15	M8	35	23	7.6	14	22.5
32				71	90	98	M6x15	M8	37	25	7.6	16	24.5

MP

	i	M _{n2} [Nm]	M _{a2} [Nm]	M _{p2} [Nm]	n ₁ [min ⁻¹]	n _{1 max} [min ⁻¹]	φ _s [arcmin]	φ _R [arcmin]	C _t Nm arcmin	SB		HB		η %	J _G [kgcm ²]			
										R _{2 max} [N]	A _{2 max} [N]	R _{2 max} [N]	A _{2 max} [N]		D			
										11 ... 12.7	14 ... 19	22 - 24	28 - 32					
MP G 105 2_3	100	180	360	2500	3500	15'	10'	22.0	1500	1600	3800	4000	94	1.85	2.01	2.33	3.07	
MP G 105 2_4	140	210	450	2800	4500	15'	10'	22.0	1500	1600	3800	4000	94	1.14	1.29	1.62	2.35	
MP G 105 2_5	140	210	450	3000	4500	15'	10'	22.0	1500	1600	3800	4000	94	1.07	1.21	1.34	2.08	
MP G 105 2_6	140	210	450	3000	4500	15'	10'	22.0	1500	1600	3800	4000	94	0.87	1.02	1.16	1.89	
MP G 105 2_7	140	210	450	3500	5000	15'	10'	22.0	1500	1600	3800	4000	94	0.98	1.14	1.27	2.00	
MP G 105 2_10	100	180	360	3500	5000	15'	10'	22.0	1500	1600	3800	4000	94	0.94	1.09	1.23	1.95	
MP G 105 3_9	100	180	360	2500	3500	15'	10'	20.5	1500	1600	3800	4000	91	1.76	1.86	2.18	2.92	
MP G 105 3_12	170	250	600	2500	3500	15'	10'	20.5	1500	1600	3800	4000	91	1.60	1.75	2.14	2.88	
MP G 105 3_15	170	250	600	2500	3500	15'	10'	20.5	1500	1600	3800	4000	91	1.57	1.73	2.10	2.84	
MP G 105 3_16	170	250	600	2800	4500	15'	10'	20.5	1500	1600	3800	4000	91	1.02	1.18	1.50	2.24	
MP G 105 3_20	170	250	600	3000	4500	15'	10'	20.5	1500	1600	3800	4000	91	1.20	1.35	1.48	2.22	
MP G 105 3_25	170	250	600	3000	4500	15'	10'	20.5	1500	1600	3800	4000	91	1.13	1.29	1.42	2.15	
MP G 105 3_28	170	250	600	3500	5000	15'	10'	20.5	1500	1600	3800	4000	91	0.94	1.10	1.23	1.97	
MP G 105 3_30	100	180	360	3500	5000	15'	10'	20.5	1500	1600	3800	4000	91	0.93	1.08	1.22	1.94	
MP G 105 3_35	170	250	600	3500	5000	15'	10'	20.5	1500	1600	3800	4000	91	1.02	1.17	1.31	2.04	
MP G 105 3_36	140	210	450	3000	4500	15'	10'	20.5	1500	1600	3800	4000	91	0.83	0.98	1.12	1.85	
MP G 105 3_40	170	250	600	3500	5000	15'	10'	20.5	1500	1600	3800	4000	91	0.96	1.11	1.25	1.98	
MP G 105 3_50	170	250	600	3500	5000	15'	10'	20.5	1500	1600	3800	4000	91	0.96	1.11	1.25	1.98	
MP G 105 3_70	170	250	600	3500	5000	15'	10'	20.5	1500	1600	3800	4000	91	0.92	1.06	1.21	1.93	
MP G 105 3_100	100	180	360	3500	5000	15'	10'	20.5	1500	1600	3800	4000	91	0.92	1.06	1.21	1.93	
MP G 105 4_48	170	250	600	2800	4500	17'	12'	17.5	1500	1600	3800	4000	89	1.06	1.21	1.53	2.27	
MP G 105 4_64	170	250	600	2800	4500	17'	12'	17.5	1500	1600	3800	4000	89	1.02	1.17	1.49	2.23	
MP G 105 4_75	170	250	600	3000	4500	17'	12'	17.5	1500	1600	3800	4000	89	1.00	1.16	1.29	2.03	
MP G 105 4_80	170	250	600	2800	4500	17'	12'	17.5	1500	1600	3800	4000	89	1.01	1.17	1.49	2.23	
MP G 105 4_84	170	250	600	3500	5000	17'	12'	17.5	1500	1600	3800	4000	89	0.95	1.11	1.24	1.98	
MP G 105 4_90	100	180	360	3500	5000	17'	12'	17.5	1500	1600	3800	4000	89	0.93	1.07	1.22	1.94	
MP G 105 4_120	170	250	600	3500	5000	17'	12'	17.5	1500	1600	3800	4000	89	0.93	1.07	1.22	1.94	
MP G 105 4_125	170	250	600	3000	4500	17'	12'	17.5	1500	1600	3800	4000	89	0.97	1.12	1.26	1.99	
MP G 105 4_140	170	250	600	3500	5000	17'	12'	17.5	1500	1600	3800	4000	89	0.94	1.10	1.23	1.97	
MP G 105 4_150	170	250	600	3500	5000	17'	12'	17.5	1500	1600	3800	4000	89	0.93	1.07	1.22	1.94	
MP G 105 4_160	170	250	600	3500	5000	17'	12'	17.5	1500	1600	3800	4000	89	0.92	1.07	1.21	1.96	
MP G 105 4_175	170	250	600	3500	5000	17'	12'	17.5	1500	1600	3800	4000	89	0.94	1.09	1.23	1.96	
MP G 105 4_200	170	250	600	3500	5000	17'	12'	17.5	1500	1600	3800	4000	89	0.92	1.07	1.21	1.94	
MP G 105 4_210	170	250	600	3500	5000	17'	12'	17.5	1500	1600	3800	4000	89	0.93	1.07	1.22	1.94	
MP G 105 4_216	170	250	600	3000	4500	17'	12'	17.5	1500	1600	3800	4000	89	0.83	0.98	1.11	1.85	
MP G 105 4_250	170	250	600	3500	5000	17'	12'	17.5	1500	1600	3800	4000	89	0.92	1.07	1.21	1.93	
MP G 105 4_280	170	250	600	3500	5000	17'	12'	17.5	1500	1600	3800	4000	89	0.92	1.06	1.21	1.93	
MP G 105 4_350	170	250	600	3500	5000	17'	12'	17.5	1500	1600	3800	4000	89	0.92	1.06	1.21	1.93	
MP G 105 4_400	170	250	600	3500	5000	17'	12'	17.5	1500	1600	3800	4000	89	0.92	1.06	1.21	1.93	
MP G 105 4_500	170	250	600	3500	5000	17'	12'	17.5	1500	1600	3800	4000	89	0.92	1.06	1.21	1.93	
MP G 105 4_700	170	250	600	3500	5000	17'	12'	17.5	1500	1600	3800	4000	89	0.92	1.06	1.21	1.93	
MP G 105 4_1000	100	180	360	3500	5000	17'	12'	17.5	1500	1600	3800	4000	89	0.92	1.06	1.21	1.93	

Please contact us for different motor adapters and input shaft bore.

MP MB 105

50D ... 130A1

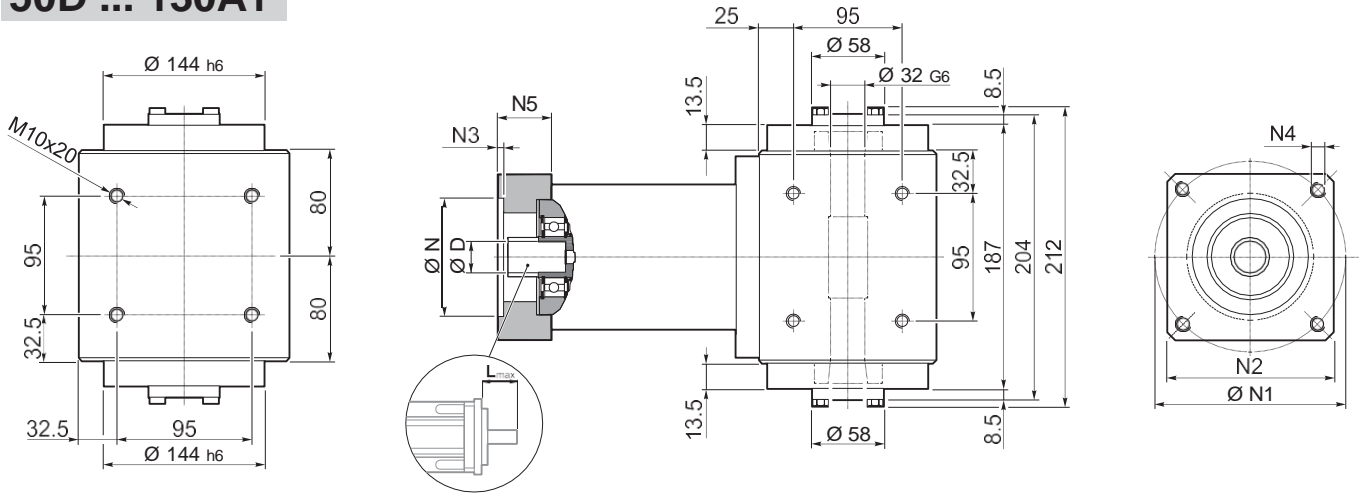

195 (MP MB 105 2)
227.5 (MP MB 105 3)
260 (MP MB 105 4)

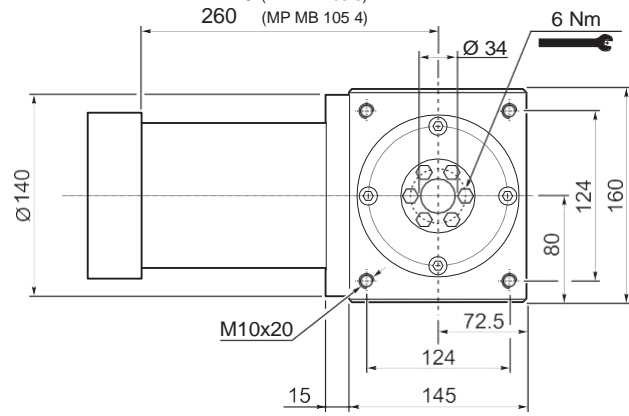

MP MB 105 2	19.2
MP MB 105 3	21.2
MP MB 105 4	23.2

MP

											N	N1	N2	N3	N4	N5	L _{max}		
50D	11	12	12.7	14	15	15.875	16	19	-	-	-	-	50	95	100	5	M6x14	28	40
55A	11	12	12.7	14	15	15.875	16	19	-	-	-	-	55	125.7	105	5	M6x16	28	40
60A2	11	12	12.7	14	15	15.875	16	19	-	-	-	-	60	75	100	6.5	M5x14	28	40
60AH2	11	12	12.7	14	15	15.875	16	19	-	-	-	-	60	75	100	4	6.5	33	40
60B1	11	12	12.7	14	15	15.875	16	19	-	-	-	-	60	85	100	6.5	M5x14	28	40
70A1	11	12	12.7	14	15	15.875	16	19	-	-	-	-	70	85	100	6.5	M6x14	28	40
70AH1	11	12	12.7	14	15	15.875	16	19	-	-	-	-	70	85	100	4	6.5	33	40
70B1	11	12	12.7	14	15	15.875	16	19	-	-	-	-	70	90	100	6.5	M5x12	28	40
80A1	11	12	12.7	14	15	15.875	16	19	-	-	-	-	80	100	100	6.5	M6x16	28	40
80AH1	11	12	12.7	14	15	15.875	16	19	-	-	-	-	80	100	100	4	6.5	33	40
95A	11	12	12.7	14	15	15.875	16	19	-	-	-	-	95	115	100	6.5	M8x18	28	40
95A1	11	12	12.7	14	15	15.875	16	19	22	24	-	-	95	115	100	6.5	M8x18	38	50
95B	11	12	12.7	14	15	15.875	16	19	-	-	-	-	95	130	115	6.5	M8x18	28	40
110A	11	12	12.7	14	15	15.875	16	19	-	-	-	-	110	130	115	6.5	M8x18	28	40
110A1	11	12	12.7	14	15	15.875	16	19	22	24	-	-	110	130	115	6.5	M8x20	38	50
110B	11	12	12.7	14	15	15.875	16	19	22	24	-	-	110	145	120	6.5	M8x20	38	50
110B1	11	12	12.7	14	15	15.875	16	19	22	24	28	-	110	145	120	6.5	M8x20	48	60
130A	11	12	12.7	14	15	15.875	16	19	22	24	-	-	130	165	140	6.5	M10x20	38	50
130A1	11	12	12.7	14	15	15.875	16	19	22	24	28	32	130	165	140	6.5	M10x25	48	60

MP MB 105

FM

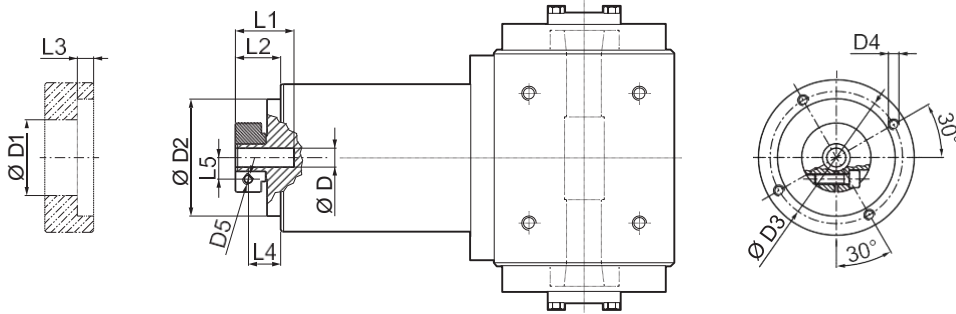

D				D1	D2	D3	D4	D5	L1	L2	L3	L4	L5
11	12	12.7		43	90	98	M6x15	M6	31.5	19.5	7.6	12	12.5
14	15	15.875	16	48	90	98	M6x15	M6	31.5	19.5	7.6	12	14.5
19				51	90	98	M6x15	M6	31.5	19.5	7.6	12	16.5
22	24			56.5	90	98	M6x15	M6	35	23	7.6	12	19
28				67	90	98	M6x15	M8	35	23	7.6	14	22.5
32				71	90	98	M6x15	M8	37	25	7.6	16	24.5

i	M _{n 2} [Nm]	M _{a 2} [Nm]	M _{p 2} [Nm]	n ₁ [min ⁻¹]	n _{1 max} [min ⁻¹]	φ _S [arcmin]	φ _R [arcmin]	C _t Nm arcmin	η %	J _G [kgcm ²]			
										11 ... 12.7	14 ... 19	22 - 24	28 - 32
MP MB 105 2_3	100	180	360	2500	3500	15'	10'	22.0	94	1.70	1.78	2.22	2.59
MP MB 105 2_4	140	210	450	2800	4500	15'	10'	22.0	94	0.99	1.06	1.51	1.87
MP MB 105 2_5	140	210	450	3000	4500	15'	10'	22.0	94	0.72	0.79	1.23	1.60
MP MB 105 2_6	140	210	450	3000	4500	15'	10'	22.0	94	0.36	0.43	0.88	1.24
MP MB 105 2_7	140	210	450	3500	5000	15'	10'	22.0	94	0.47	0.55	0.99	1.35
MP MB 105 2_10	100	180	360	3500	5000	15'	10'	22.0	94	0.33	0.41	0.85	1.21
MP MB 105 3_9	100	180	360	2500	3500	15'	10'	20.5	91	1.58	1.63	2.07	2.44
MP MB 105 3_12	170	250	600	2500	3500	15'	10'	20.5	91	1.52	1.59	2.03	2.40
MP MB 105 3_15	170	250	600	2500	3500	15'	10'	20.5	91	1.47	1.55	1.99	2.36
MP MB 105 3_16	170	250	600	2800	4500	15'	10'	20.5	91	0.87	0.95	1.39	1.76
MP MB 105 3_20	170	250	600	3000	4500	15'	10'	20.5	91	0.86	0.93	1.37	1.74
MP MB 105 3_25	170	250	600	3000	4500	15'	10'	20.5	91	0.63	0.71	1.15	1.51
MP MB 105 3_28	170	250	600	3500	5000	15'	10'	20.5	91	0.43	0.51	0.95	1.32
MP MB 105 3_30	100	180	360	3500	5000	15'	10'	20.5	91	0.32	0.40	0.84	1.20
MP MB 105 3_35	170	250	600	3500	5000	15'	10'	20.5	91	0.43	0.50	0.95	1.31
MP MB 105 3_36	140	210	450	3000	4500	15'	10'	20.5	91	0.32	0.39	0.84	1.20
MP MB 105 3_40	170	250	600	3500	5000	15'	10'	20.5	91	0.31	0.39	0.83	1.20
MP MB 105 3_50	170	250	600	3500	5000	15'	10'	20.5	91	0.31	0.39	0.83	1.19
MP MB 105 3_70	170	250	600	3500	5000	15'	10'	20.5	91	0.31	0.38	0.83	1.19
MP MB 105 3_100	100	180	360	3500	5000	15'	10'	20.5	91	0.31	0.38	0.83	1.19
MP MB 105 4_48	170	250	600	2800	4500	17'	12'	17.5	89	0.91	0.98	1.42	1.79
MP MB 105 4_64	170	250	600	2800	4500	17'	12'	17.5	89	0.87	0.94	1.38	1.75
MP MB 105 4_75	170	250	600	3000	4500	17'	12'	17.5	89	0.66	0.74	1.18	1.55
MP MB 105 4_80	170	250	600	2800	4500	17'	12'	17.5	89	0.86	0.94	1.38	1.75
MP MB 105 4_84	170	250	600	3500	5000	17'	12'	17.5	89	0.44	0.52	0.96	1.33
MP MB 105 4_90	100	180	360	3500	5000	17'	12'	17.5	89	0.32	0.39	0.84	1.20
MP MB 105 4_120	170	250	600	3500	5000	17'	12'	17.5	89	0.32	0.39	0.84	1.20
MP MB 105 4_125	170	250	600	3000	4500	17'	12'	17.5	89	0.63	0.70	1.15	1.51
MP MB 105 4_140	170	250	600	3500	5000	17'	12'	17.5	89	0.43	0.51	0.95	1.32
MP MB 105 4_150	170	250	600	3500	5000	17'	12'	17.5	89	0.32	0.39	0.84	1.20
MP MB 105 4_160	170	250	600	3500	5000	17'	12'	17.5	89	0.31	0.39	0.83	1.21
MP MB 105 4_175	170	250	600	3500	5000	17'	12'	17.5	89	0.43	0.50	0.95	1.31
MP MB 105 4_200	170	250	600	3500	5000	17'	12'	17.5	89	0.31	0.39	0.83	1.20
MP MB 105 4_210	170	250	600	3500	5000	17'	12'	17.5	89	0.32	0.39	0.84	1.20
MP MB 105 4_216	170	250	600	3000	4500	17'	12'	17.5	89	0.31	0.39	0.83	1.20
MP MB 105 4_250	170	250	600	3500	5000	17'	12'	17.5	89	0.31	0.39	0.83	1.19
MP MB 105 4_280	170	250	600	3500	5000	17'	12'	17.5	89	0.31	0.38	0.83	1.19
MP MB 105 4_350	170	250	600	3500	5000	17'	12'	17.5	89	0.31	0.38	0.83	1.19
MP MB 105 4_400	170	250	600	3500	5000	17'	12'	17.5	89	0.31	0.38	0.83	1.19
MP MB 105 4_500	170	250	600	3500	5000	17'	12'	17.5	89	0.31	0.38	0.83	1.19
MP MB 105 4_700	170	250	600	3500	5000	17'	12'	17.5	89	0.31	0.38	0.83	1.19
MP MB 105 4_1000	100	180	360	3500	5000	17'	12'	17.5	89	0.31	0.38	0.83	1.19

MP

Please contact us for different motor adapters and input shaft bore.

MP 130

IS

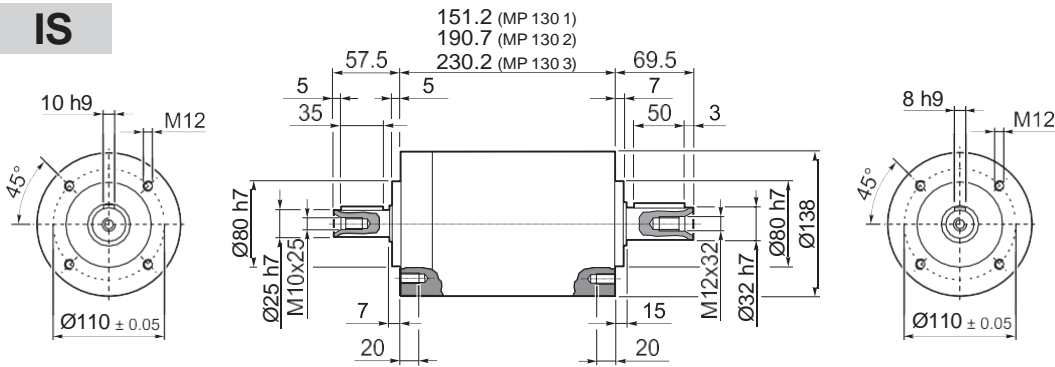

MP 130 1	12.0
MP 130 2	15.5
MP 130 3	18.5

MP

55A1 ... 180A1

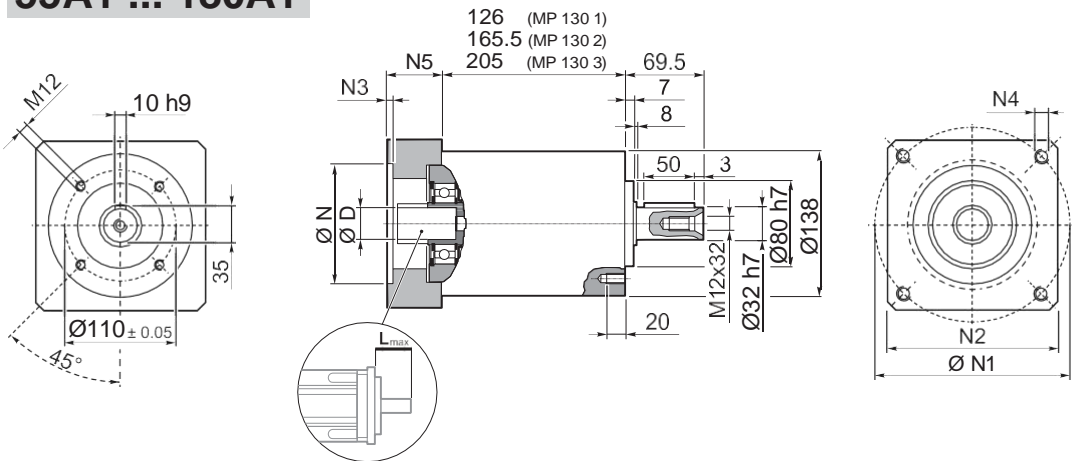

MP 130 1	12.0
MP 130 2	15.5
MP 130 3	18.5

											N	N1	N2	N3	N4	N5	L _{max}
55A1	14	15.875	16	19	-	-	-	-	-	-	55.5	125.7	130	4	M6x15	39.5	50
80A2	14	15.875	16	19	-	-	-	-	-	-	80	100	130	4	M6x15	39.5	50
95A1	14	15.875	16	19	22	24	-	-	-	-	95	115	130	4	M8x20	39.5	50
110A1	14	15.875	16	19	22	24	-	-	-	-	110	130	130	4	M8x20	39.5	50
110B1	14	15.875	16	19	22	24	-	-	-	-	110	145	130	6.5	M8x20	49.5	60
114A0	14	15.875	16	19	22	24	-	-	-	-	114.3	200	170	5.5	M12x25	39.5	50
114A	14	15.875	16	19	22	24	28	32	35	38	114.3	200	170	5.5	M12x25	69.5	80
130A	14	15.875	16	19	22	24	-	-	-	-	130	165	140	4	M10x20	39.5	50
130A1	14	15.875	16	19	22	24	28	32	-	-	130	165	140	4	M10x20	49.5	60
180A	14	15.875	16	19	22	24	28	32	-	-	180	215	190	5.5	M14x25	49.5	60
180A1	14	15.875	16	19	22	24	28	32	35	38	180	215	190	5.5	M14x25	69.5	80

MP 130

FM

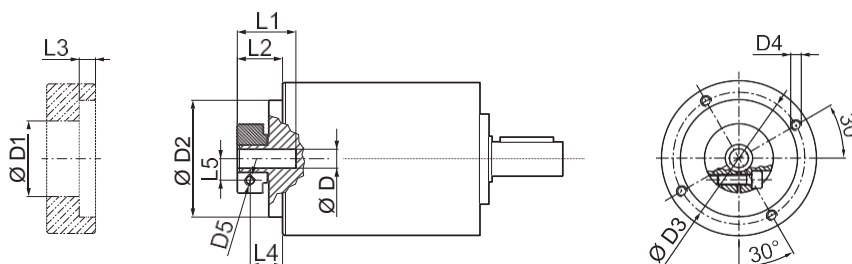

D	D1	D2	D3	D4	D5	L1	L2	L3	L4	L5
14	48	113	125.5	M8x15	M6	40	27.5	6	20	14.5
19	51	113	125.5	M8x15	M6	40	27.5	6	20	16.5
22	56.5	113	125.5	M8x15	M6	41	28.5	6	19.5	19
28	67	113	125.5	M8x15	M8	41	28.5	6	19.5	22.5
32	71	113	125.5	M8x15	M8	41	28.5	6	19.5	24.5
35	73	113	125.5	M8x15	M8	50	37.5	11.25	26	26
38	77.5	113	125.5	M8x15	M8	50	37.5	11.25	26	28

i	M _{n 2} [Nm]	M _{a 2} [Nm]	M _{p 2} [Nm]	n ₁ [min ⁻¹]	n _{1 max} [min ⁻¹]	φ _S [arcmin]	φ _R [arcmin]	C _t Nm/arcmin	R _{1 max} [N]	R _{2 max} [N]	A _{2 max} [N]	η %	J _G [kgcm ²]			
													14 ... 19	22 - 24	28 - 32	35 - 38
MP 130 1_3	215	400	800	2100	3000	15'	10'	43.0	800	5500	6500	97	5.25	5.46	5.81	7.16
MP 130 1_4	380	600	1100	2400	3500	15'	10'	43.0	800	5500	6500	97	3.06	3.26	3.61	4.97
MP 130 1_5	380	600	1100	2900	3500	15'	10'	43.0	800	5500	6500	97	2.22	2.42	2.77	4.13
MP 130 1_6	380	600	1100	2900	3500	15'	10'	43.0	800	5500	6500	97	1.19	1.40	1.75	3.10
MP 130 1_7	380	600	1100	3200	4000	15'	10'	43.0	800	5500	6500	97	1.47	1.68	2.03	3.38
MP 130 1_10	215	400	800	3200	4000	15'	10'	43.0	800	5500	6500	97	1.04	1.25	1.60	2.95
MP 130 2_9	215	400	800	2100	3000	15'	10'	37.5	800	5500	6500	94	4.82	5.02	5.37	6.72
MP 130 2_12	450	700	1300	2100	3000	15'	10'	37.5	800	5500	6500	94	4.57	4.78	5.13	6.48
MP 130 2_15	450	700	1300	2100	3000	15'	10'	37.5	800	5500	6500	94	4.48	4.69	5.04	6.39
MP 130 2_16	450	700	1300	2400	3500	15'	10'	37.5	800	5500	6500	94	2.67	2.88	3.23	4.58
MP 130 2_20	450	700	1300	2900	3500	15'	10'	37.5	800	5500	6500	94	1.97	2.18	2.53	3.88
MP 130 2_25	450	700	1300	2900	3500	15'	10'	37.5	800	5500	6500	94	1.94	2.15	2.50	3.85
MP 130 2_28	450	700	1300	3200	4000	15'	10'	37.5	800	5500	6500	94	1.34	1.55	1.90	3.25
MP 130 2_30	215	400	800	3200	4000	15'	10'	37.5	800	5500	6500	94	1.00	1.21	1.56	2.91
MP 130 2_35	450	700	1300	3200	4000	15'	10'	37.5	800	5500	6500	94	1.33	1.53	1.88	3.24
MP 130 2_36	380	600	1100	2900	3500	15'	10'	37.5	800	5500	6500	94	1.05	1.26	1.61	2.96
MP 130 2_40	450	700	1300	3200	4000	15'	10'	37.5	800	5500	6500	94	0.98	1.19	1.54	2.89
MP 130 2_50	450	700	1300	3200	4000	15'	10'	37.5	800	5500	6500	94	0.97	1.18	1.53	2.88
MP 130 2_70	450	700	1300	3200	4000	15'	10'	37.5	800	5500	6500	94	0.96	1.17	1.52	2.87
MP 130 2_100	215	400	800	3200	4000	15'	10'	37.5	800	5500	6500	94	0.96	1.17	1.52	2.87
MP 130 3_48	450	700	1300	2400	3500	17'	12'	29.5	800	5500	6500	91	2.77	2.98	3.33	4.68
MP 130 3_64	450	700	1300	2400	3500	17'	12'	29.5	800	5500	6500	91	2.65	2.86	3.21	4.56
MP 130 3_75	450	700	1300	2900	3500	17'	12'	29.5	800	5500	6500	91	2.03	2.24	2.59	3.94
MP 130 3_80	450	700	1300	2400	3500	17'	12'	29.5	800	5500	6500	91	2.65	2.85	3.20	4.56
MP 130 3_84	450	700	1300	3200	4000	17'	12'	29.5	800	5500	6500	91	1.37	1.58	1.93	3.28
MP 130 3_90	215	400	800	3200	4000	17'	12'	29.5	800	5500	6500	91	1.00	1.20	1.55	2.91
MP 130 3_120	450	700	1300	3200	4000	17'	12'	29.5	800	5500	6500	91	0.99	1.20	1.55	2.90
MP 130 3_125	450	700	1300	2900	3500	17'	12'	29.5	800	5500	6500	91	1.93	2.13	2.48	3.84
MP 130 3_140	450	700	1300	3200	4000	17'	12'	29.5	800	5500	6500	91	1.34	1.54	1.89	3.25
MP 130 3_150	450	700	1300	3200	4000	17'	12'	29.5	800	5500	6500	91	0.99	1.20	1.55	2.90
MP 130 3_160	450	700	1300	3200	4000	17'	12'	29.5	800	5500	6500	91	0.98	1.18	1.53	2.89
MP 130 3_175	450	700	1300	3200	4000	17'	12'	29.5	800	5500	6500	91	1.32	1.53	1.88	3.23
MP 130 3_200	450	700	1300	3200	4000	17'	12'	29.5	800	5500	6500	91	0.97	1.18	1.53	2.88
MP 130 3_210	450	700	1300	3200	4000	17'	12'	29.5	800	5500	6500	91	0.99	1.20	1.55	2.90
MP 130 3_216	450	700	1300	2900	3500	17'	12'	29.5	800	5500	6500	91	1.05	1.26	1.61	2.96
MP 130 3_250	450	700	1300	3200	4000	17'	12'	29.5	800	5500	6500	91	0.97	1.18	1.53	2.88
MP 130 3_280	450	700	1300	3200	4000	17'	12'	29.5	800	5500	6500	91	0.96	1.17	1.52	2.87
MP 130 3_350	450	700	1300	3200	4000	17'	12'	29.5	800	5500	6500	91	0.96	1.17	1.52	2.87
MP 130 3_400	450	700	1300	3200	4000	17'	12'	29.5	800	5500	6500	91	0.96	1.17	1.52	2.87
MP 130 3_500	450	700	1300	3200	4000	17'	12'	29.5	800	5500	6500	91	0.96	1.17	1.52	2.87
MP 130 3_700	450	700	1300	3200	4000	17'	12'	29.5	800	5500	6500	91	0.96	1.17	1.52	2.87
MP 130 3_1000	215	400	800	3200	4000	17'	12'	29.5	800	5500	6500	91	0.96	1.17	1.52	2.87

MP

Please contact us for different motor adapters and input shaft bore.

MP G 130

55A1 ... 180A1

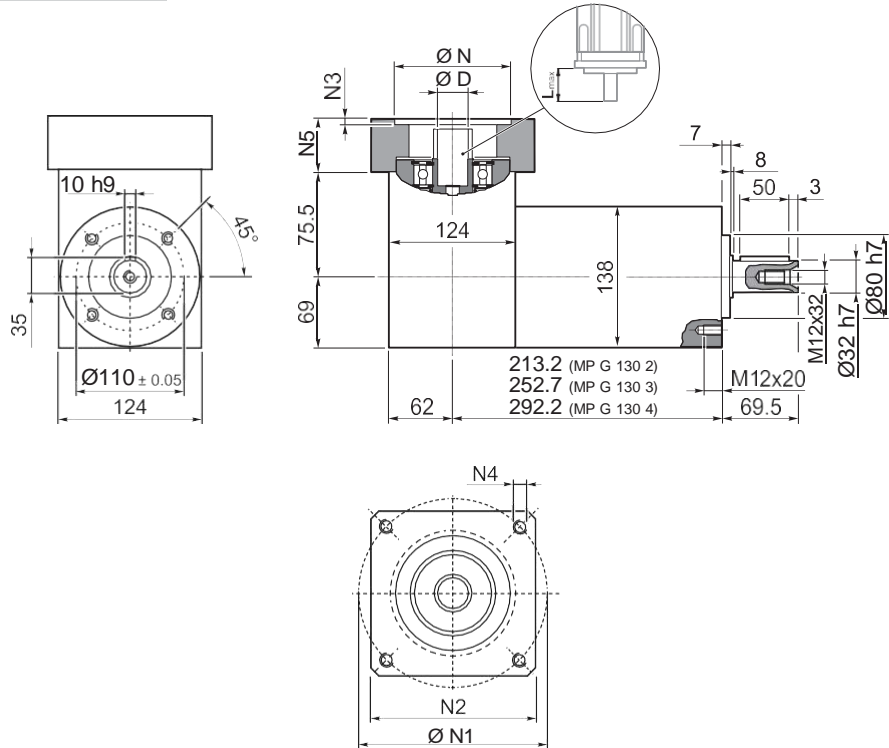

MP G 130 2	16.0
MP G 130 3	19.5
MP G 130 4	22.5

MP

											N	N1	N2	N3	N4	N5	L _{max}
	14	15.875	16	19													
55A1	14	15.875	16	19	-	-	-	-	-	-	55.5	125.7	130	4	M6x15	39.5	50
80A2	14	15.875	16	19	-	-	-	-	-	-	80	100	130	4	M6x15	39.5	50
95A1	14	15.875	16	19	22	24	-	-	-	-	95	115	130	4	M8x20	39.5	50
110A1	14	15.875	16	19	22	24	-	-	-	-	110	130	130	4	M8x20	39.5	50
110B1	14	15.875	16	19	22	24	-	-	-	-	110	145	130	6.5	M8x20	49.5	60
114A0	14	15.875	16	19	22	24	-	-	-	-	114.3	200	170	5.5	M12x25	39.5	50
114A	14	15.875	16	19	22	24	28	32	35	38	114.3	200	170	5.5	M12x25	69.5	80
130A	14	15.875	16	19	22	24	-	-	-	-	130	165	140	4	M10x20	39.5	50
130A1	14	15.875	16	19	22	24	28	32	-	-	130	165	140	4	M10x20	49.5	60
180A	14	15.875	16	19	22	24	28	32	-	-	180	215	190	5.5	M14x25	49.5	60
180A1	14	15.875	16	19	22	24	28	32	35	38	180	215	190	5.5	M14x25	69.5	80

MP G 130

FM

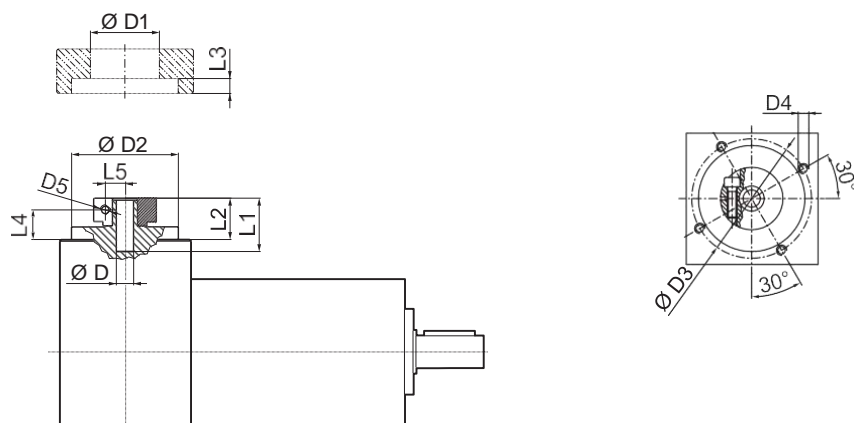

D			D1	D2	D3	D4	D5	L1	L2	L3	L4	L5
14	15.875	16	48	113	125.5	M8x15	M6	40	27.5	6	20	14.5
19			51	113	125.5	M8x15	M6	40	27.5	6	20	16.5
22	24		56.5	113	125.5	M8x15	M6	41	28.5	6	19.5	19
28			67	113	125.5	M8x15	M8	41	28.5	6	19.5	22.5
32			71	113	125.5	M8x15	M8	41	28.5	6	19.5	24.5
35			73	113	125.5	M8x15	M8	50	37.5	11.25	26	26
38			77.5	113	125.5	M8x15	M8	50	37.5	11.25	26	28

MP

 i	M _{n2}	M _{a2}	M _{p2}	n ₁	n _{1 max}	φ _S	φ _R	C _t	R _{2 max}	A _{2 max}	η	J _G [kgcm ²]			
	[Nm]	[Nm]	[Nm]	[min ⁻¹]	[min ⁻¹]	[arcmin]	[arcmin]	[Nm [arcmin]	[N]	[N]	%	14 ... 19	22 - 24	28 - 32	35 - 38
MP G 130 2_3	215	400	800	2100	3000	15'	10'	43.0	5500	6500	94	7.09	7.28	7.66	10.37
MP G 130 2_4	380	600	1100	2400	3500	15'	10'	43.0	5500	6500	94	4.90	5.08	5.46	8.18
MP G 130 2_5	380	600	1100	2900	3500	15'	10'	43.0	5500	6500	94	4.81	4.99	5.38	8.10
MP G 130 2_6	380	600	1100	2900	3500	15'	10'	43.0	5500	6500	94	4.45	4.64	5.03	7.73
MP G 130 2_7	380	600	1100	3200	4000	15'	10'	43.0	5500	6500	94	4.73	4.92	5.31	8.01
MP G 130 2_10	215	400	800	3200	4000	15'	10'	43.0	5500	6500	94	4.68	4.88	5.26	7.97
MP G 130 3_9	215	400	800	2100	3000	15'	10'	37.5	5500	6500	91	6.66	6.84	7.22	9.93
MP G 130 3_12	450	700	1300	2100	3000	15'	10'	37.5	5500	6500	91	6.25	6.45	6.84	9.54
MP G 130 3_15	450	700	1300	2100	3000	15'	10'	37.5	5500	6500	91	6.25	6.44	6.83	9.53
MP G 130 3_16	450	700	1300	2400	3500	15'	10'	37.5	5500	6500	91	4.51	4.70	5.08	7.79
MP G 130 3_20	450	700	1300	2900	3500	15'	10'	37.5	5500	6500	91	4.56	5.36	5.75	8.45
MP G 130 3_25	450	700	1300	2900	3500	15'	10'	37.5	5500	6500	91	5.13	4.72	5.11	7.82
MP G 130 3_28	450	700	1300	3200	4000	15'	10'	37.5	5500	6500	91	4.60	4.79	5.18	7.88
MP G 130 3_30	215	400	800	3200	4000	15'	10'	37.5	5500	6500	91	4.64	4.84	5.22	7.93
MP G 130 3_35	450	700	1300	3200	4000	15'	10'	37.5	5500	6500	91	4.92	5.10	5.49	8.20
MP G 130 3_36	380	600	1100	2900	3500	15'	10'	37.5	5500	6500	91	4.31	4.50	4.89	7.59
MP G 130 3_40	450	700	1300	3200	4000	15'	10'	37.5	5500	6500	91	4.77	4.96	5.35	8.05
MP G 130 3_50	450	700	1300	3200	4000	15'	10'	37.5	5500	6500	91	4.76	4.96	5.34	8.05
MP G 130 3_70	450	700	1300	3200	4000	15'	10'	37.5	5500	6500	91	4.60	4.80	5.18	7.89
MP G 130 3_100	215	400	800	3200	4000	15'	10'	37.5	5500	6500	91	4.60	4.80	5.18	7.89
MP G 130 4_48	450	700	1300	2400	3500	17'	12'	29.5	5500	6500	89	4.61	4.81	5.18	7.89
MP G 130 4_64	450	700	1300	2400	3500	17'	12'	29.5	5500	6500	89	4.49	4.68	5.06	7.77
MP G 130 4_75	450	700	1300	2900	3500	17'	12'	29.5	5500	6500	89	4.62	4.81	5.20	7.91
MP G 130 4_80	450	700	1300	2400	3500	17'	12'	29.5	5500	6500	89	4.49	4.67	5.05	7.77
MP G 130 4_84	450	700	1300	3200	4000	17'	12'	29.5	5500	6500	89	4.63	4.82	5.21	7.91
MP G 130 4_90	215	400	800	3200	4000	17'	12'	29.5	5500	6500	89	4.64	4.83	5.21	7.93
MP G 130 4_120	450	700	1300	3200	4000	17'	12'	29.5	5500	6500	89	4.63	4.83	5.21	7.92
MP G 130 4_125	450	700	1300	2900	3500	17'	12'	29.5	5500	6500	89	4.52	4.70	5.09	7.81
MP G 130 4_140	450	700	1300	3200	4000	17'	12'	29.5	5500	6500	89	4.60	4.78	5.17	7.88
MP G 130 4_150	450	700	1300	3200	4000	17'	12'	29.5	5500	6500	89	4.63	4.83	5.21	7.92
MP G 130 4_160	450	700	1300	3200	4000	17'	12'	29.5	5500	6500	89	4.62	4.81	5.19	7.91
MP G 130 4_175	450	700	1300	3200	4000	17'	12'	29.5	5500	6500	89	4.58	4.77	5.16	7.86
MP G 130 4_200	450	700	1300	3200	4000	17'	12'	29.5	5500	6500	89	4.61	4.81	5.19	7.90
MP G 130 4_210	450	700	1300	3200	4000	17'	12'	29.5	5500	6500	89	4.63	4.83	5.21	7.92
MP G 130 4_216	450	700	1300	2900	3500	17'	12'	29.5	5500	6500	89	4.31	4.50	4.89	7.59
MP G 130 4_250	450	700	1300	3200	4000	17'	12'	29.5	5500	6500	89	4.61	4.81	5.19	7.90
MP G 130 4_280	450	700	1300	3200	4000	17'	12'	29.5	5500	6500	89	4.60	4.80	5.18	7.89
MP G 130 4_350	450	700	1300	3200	4000	17'	12'	29.5	5500	6500	89	4.60	4.80	5.18	7.89
MP G 130 4_400	450	700	1300	3200	4000	17'	12'	29.5	5500	6500	89	4.60	4.80	5.18	7.89
MP G 130 4_500	450	700	1300	3200	4000	17'	12'	29.5	5500	6500	89	4.60	4.80	5.18	7.89
MP G 130 4_700	450	700	1300	3200	4000	17'	12'	29.5	5500	6500	89	4.60	4.80	5.18	7.89
MP G 130 4_1000	215	400	800	3200	4000	17'	12'	29.5	5500	6500	89	4.60	4.80	5.18	7.89

Please contact us for different motor adapters and input shaft bore.

MP MB 130

55A1 ... 180A1

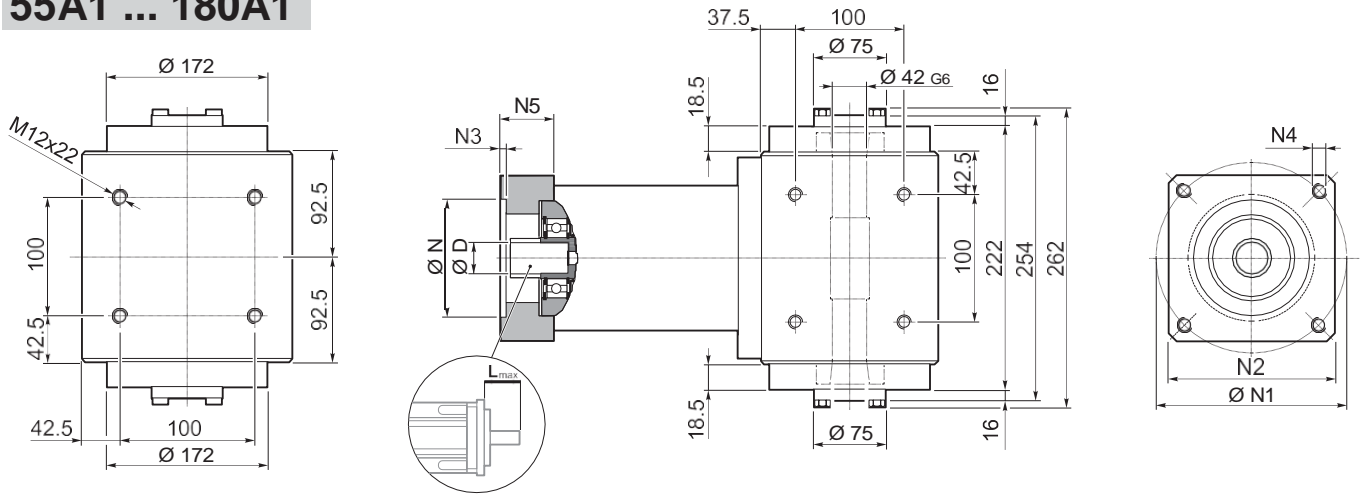

MP

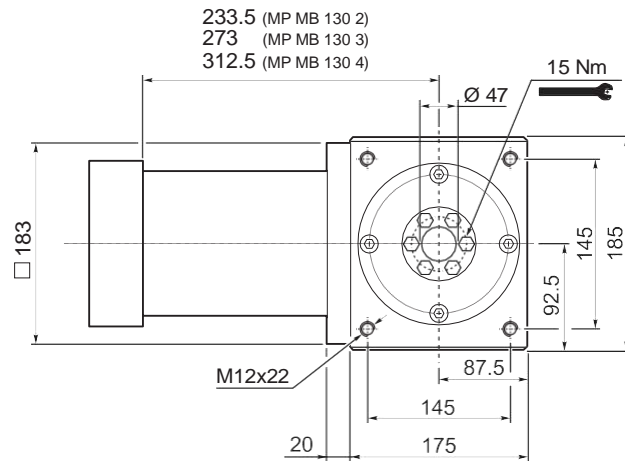

MP MB 130 2	54
MP MB 130 3	58
MP MB 130 4	61

											N	N1	N2	N3	N4	N5	L _{max}
	14	15.875	16	19	-	-	-	-	-	-							
55A1	14	15.875	16	19	-	-	-	-	-	-	55.5	125.7	130	4	M6x15	39.5	50
80A2	14	15.875	16	19	-	-	-	-	-	-	80	100	130	4	M6x15	39.5	50
95A1	14	15.875	16	19	22	24	-	-	-	-	95	115	130	4	M8x20	39.5	50
110A1	14	15.875	16	19	22	24	-	-	-	-	110	130	130	4	M8x20	39.5	50
110B1	14	15.875	16	19	22	24	-	-	-	-	110	145	130	6.5	M8x20	49.5	60
114A0	14	15.875	16	19	22	24	-	-	-	-	114.3	200	170	5.5	M12x25	39.5	50
114A	14	15.875	16	19	22	24	28	32	35	38	114.3	200	170	5.5	M12x25	69.5	80
130A	14	15.875	16	19	22	24	-	-	-	-	130	165	140	4	M10x20	39.5	50
130A1	14	15.875	16	19	22	24	28	32	-	-	130	165	140	4	M10x20	49.5	60
180A	14	15.875	16	19	22	24	28	32	-	-	180	215	190	5.5	M14x25	49.5	60
180A1	14	15.875	16	19	22	24	28	32	35	38	180	215	190	5.5	M14x25	69.5	80

MP MB 130

FM

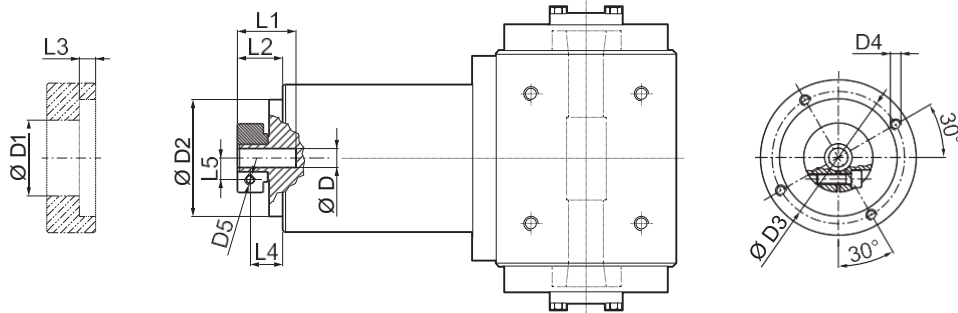

	D1	D2	D3	D4	D5	L1	L2	L3	L4	L5
14	48	113	125.5	M8x15	M6	40	27.5	6	20	14.5
19	51	113	125.5	M8x15	M6	40	27.5	6	20	16.5
22	56.5	113	125.5	M8x15	M6	41	28.5	6	19.5	19
28	67	113	125.5	M8x15	M8	41	28.5	6	19.5	22.5
32	71	113	125.5	M8x15	M8	41	28.5	6	19.5	24.5
35	73	113	125.5	M8x15	M8	50	37.5	11.25	26	26
38	77.5	113	125.5	M8x15	M8	50	37.5	11.25	26	28

	M_{n2}	M_{a2}	M_{p2}	n_1	n_{1max}	ϕ_S	ϕ_R	C_t	η	J_G [kgcm ²]			
										14 ... 19	22 - 24	28 - 32	35 - 38
MP MB 130 2 3	215	400	800	2100	3000	15'	10'	43.0	94	5.25	5.46	5.81	7.16
MP MB 130 2 4	380	600	1100	2400	3500	15'	10'	43.0	94	3.06	3.26	3.61	4.97
MP MB 130 2 5	380	600	1100	2900	3500	15'	10'	43.0	94	2.22	2.42	2.77	4.13
MP MB 130 2 6	380	600	1100	2900	3500	15'	10'	43.0	94	1.19	1.40	1.75	3.10
MP MB 130 2 7	380	600	1100	3200	4000	15'	10'	43.0	94	1.47	1.68	2.03	3.38
MP MB 130 2 10	215	400	800	3200	4000	15'	10'	43.0	94	1.04	1.25	1.60	2.95
MP MB 130 3 9	215	400	800	2100	3000	15'	10'	37.5	91	4.82	5.02	5.37	6.72
MP MB 130 3 12	450	700	1300	2100	3000	15'	10'	37.5	91	4.57	4.78	5.13	6.48
MP MB 130 3 15	450	700	1300	2100	3000	15'	10'	37.5	91	4.48	4.69	5.04	6.39
MP MB 130 3 16	450	700	1300	2400	3500	15'	10'	37.5	91	2.67	2.88	3.23	4.58
MP MB 130 3 20	450	700	1300	2900	3500	15'	10'	37.5	91	1.97	2.18	2.53	3.88
MP MB 130 3 25	450	700	1300	2900	3500	15'	10'	37.5	91	1.94	2.15	2.50	3.85
MP MB 130 3 28	450	700	1300	3200	4000	15'	10'	37.5	91	1.34	1.55	1.90	3.25
MP MB 130 3 30	215	400	800	3200	4000	15'	10'	37.5	91	1.00	1.21	1.56	2.91
MP MB 130 3 35	450	700	1300	3200	4000	15'	10'	37.5	91	1.33	1.53	1.88	3.24
MP MB 130 3 36	380	600	1100	2900	3500	15'	10'	37.5	91	1.05	1.26	1.61	2.96
MP MB 130 3 40	450	700	1300	3200	4000	15'	10'	37.5	91	0.98	1.19	1.54	2.89
MP MB 130 3 50	450	700	1300	3200	4000	15'	10'	37.5	91	0.97	1.18	1.53	2.88
MP MB 130 3 70	450	700	1300	3200	4000	15'	10'	37.5	91	0.96	1.17	1.52	2.87
MP MB 130 3 100	215	400	800	3200	4000	15'	10'	37.5	91	0.96	1.17	1.52	2.87
MP MB 130 4 48	450	700	1300	2400	3500	17'	12'	29.5	89	2.77	2.98	3.33	4.68
MP MB 130 4 64	450	700	1300	2400	3500	17'	12'	29.5	89	2.65	2.86	3.21	4.56
MP MB 130 4 75	450	700	1300	2900	3500	17'	12'	29.5	89	2.03	2.24	2.59	3.94
MP MB 130 4 80	450	700	1300	2400	3500	17'	12'	29.5	89	2.65	2.85	3.20	4.56
MP MB 130 4 84	450	700	1300	3200	4000	17'	12'	29.5	89	1.37	1.58	1.93	3.28
MP MB 130 4 90	215	400	800	3200	4000	17'	12'	29.5	89	1.00	1.20	1.55	2.91
MP MB 130 4 120	450	700	1300	3200	4000	17'	12'	29.5	89	0.99	1.20	1.55	2.90
MP MB 130 4 125	450	700	1300	2900	3500	17'	12'	29.5	89	1.93	2.13	2.48	3.84
MP MB 130 4 140	450	700	1300	3200	4000	17'	12'	29.5	89	1.34	1.54	1.89	3.25
MP MB 130 4 150	450	700	1300	3200	4000	17'	12'	29.5	89	0.99	1.20	1.55	2.90
MP MB 130 4 160	450	700	1300	3200	4000	17'	12'	29.5	89	0.98	1.18	1.53	2.89
MP MB 130 4 175	450	700	1300	3200	4000	17'	12'	29.5	89	1.32	1.53	1.88	3.23
MP MB 130 4 200	450	700	1300	3200	4000	17'	12'	29.5	89	0.97	1.18	1.53	2.88
MP MB 130 4 210	450	700	1300	3200	4000	17'	12'	29.5	89	0.99	1.20	1.55	2.90
MP MB 130 4 216	450	700	1300	2900	3500	17'	12'	29.5	89	1.05	1.26	1.61	2.96
MP MB 130 4 250	450	700	1300	3200	4000	17'	12'	29.5	89	0.97	1.18	1.53	2.88
MP MB 130 4 280	450	700	1300	3200	4000	17'	12'	29.5	89	0.96	1.17	1.52	2.87
MP MB 130 4 350	450	700	1300	3200	4000	17'	12'	29.5	89	0.96	1.17	1.52	2.87
MP MB 130 4 400	450	700	1300	3200	4000	17'	12'	29.5	89	0.96	1.17	1.52	2.87
MP MB 130 4 500	450	700	1300	3200	4000	17'	12'	29.5	89	0.96	1.17	1.52	2.87
MP MB 130 4 700	450	700	1300	3200	4000	17'	12'	29.5	89	0.96	1.17	1.52	2.87
MP MB 130 4 1000	215	400	800	3200	4000	17'	12'	29.5	89	0.96	1.17	1.52	2.87

MP

Please contact us for different motor adapters and input shaft bore.

MP 160

IS

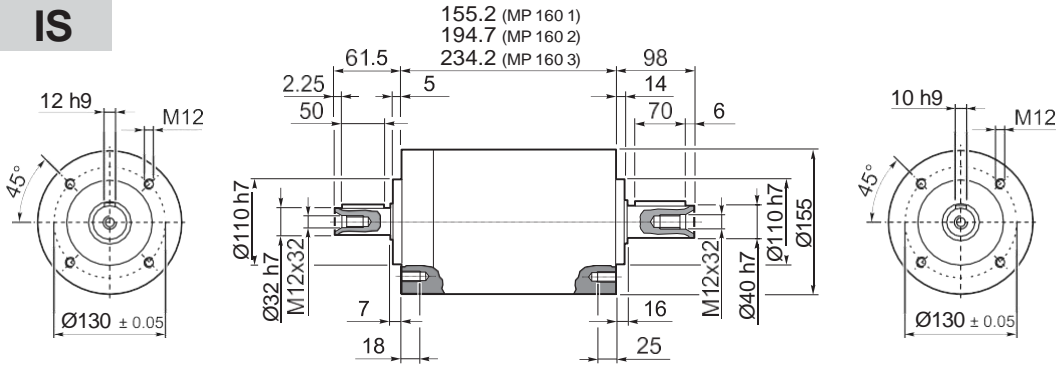

155.2 (MP 160 1)
194.7 (MP 160 2)
234.2 (MP 160 3)

MP 160 1	17.0
MP 160 2	21
MP 160 3	28

MP

55A1 ... 180A1

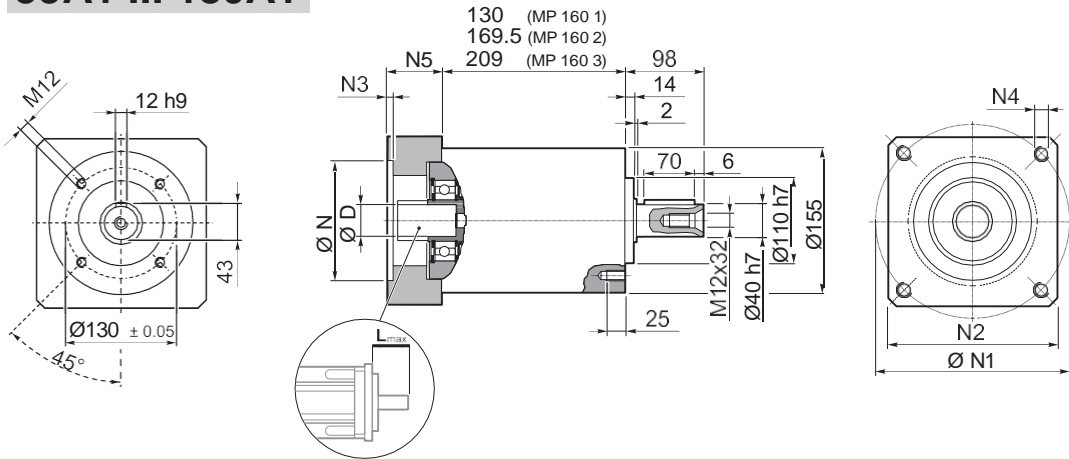

130 (MP 160 1)
169.5 (MP 160 2)
209 (MP 160 3)

MP 160 1	17.0
MP 160 2	21
MP 160 3	28

											N	N1	N2	N3	N4	N5	L _{max}
55A1	14	15.875	16	19	-	-	-	-	-	-	55.5	125.7	140	5	M6x15	39.5	50
80A2	14	15.875	16	19	-	-	-	-	-	-	80	100	140	5	M6x15	39.5	50
95A1	14	15.875	16	19	22	24	-	-	-	-	95	115	140	5	M8x20	39.5	50
110A1	14	15.875	16	19	22	24	-	-	-	-	110	130	140	5	M8x20	39.5	50
110B1	14	15.875	16	19	22	24	-	-	-	-	110	145	140	6.5	M8x20	49.5	60
114A	14	15.875	16	19	22	24	28	32	35	38	114.3	200	170	6.5	M12x25	69.5	80
130A	14	15.875	16	19	22	24	-	-	-	-	130	165	140	5	M10x20	39.5	50
130A1	14	15.875	16	19	22	24	28	32	-	-	130	165	140	5	M10x20	49.5	60
180A	14	15.875	16	19	22	24	28	32	-	-	180	215	190	5.5	M14x25	49.5	60
180A1	14	15.875	16	19	22	24	28	32	35	38	180	215	190	5.5	M14x25	69.5	80

MP 160

FM

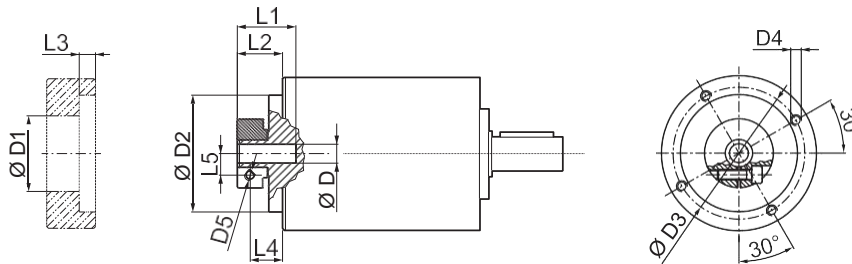

D			D1	D2	D3	D4	D5	L1	L2	L3	L4	L5
14	15.875	16	48	130	142.5	M8x16	M6	40	27.5	6	20	14.5
19			51	130	142.5	M8x16	M6	40	27.5	6	20	16.5
22	24		56.5	130	142.5	M8x16	M6	41	28.5	6	19.5	19
28			67	130	142.5	M8x16	M8	41	28.5	6	19.5	22.5
32			71	130	142.5	M8x16	M8	41	28.5	6	19.5	24.5
35			73	130	142.5	M8x16	M8	50	37.5	11.25	26	26
38			77.5	130	142.5	M8x16	M8	50	37.5	11.25	26	28

 i	M _{n 2}	M _{a 2}	M _{p 2}	n ₁	n _{1 max}	ϕ _S	ϕ _R	C _t	R _{1 max}	R _{2 max}	A _{2 max}	η	J _G [kgcm ²]			
	[Nm]	[Nm]	[Nm]	[min ⁻¹]	[min ⁻¹]	[arcmin]	[arcmin]	$\frac{Nm}{arcmin}$	[N]	[N]	[N]	%	14 ... 19	22 - 24	28 - 32	35 - 38
MP 160 1_3	350	660	1200	1900	3000	15'	10'	90	1200	6500	7500	97	8.39	8.60	8.95	10.30
MP 160 1_4	500	750	1400	2200	3500	15'	10'	90	1200	6500	7500	97	4.68	4.89	5.24	6.59
MP 160 1_5	500	750	1400	2500	3500	15'	10'	90	1200	6500	7500	97	3.28	3.49	3.84	5.19
MP 160 1_6	500	750	1400	2500	3500	15'	10'	90	1200	6500	7500	97	1.32	1.53	1.88	3.23
MP 160 1_7	500	750	1400	3000	4000	15'	10'	90	1200	6500	7500	97	2.03	2.24	2.59	3.94
MP 160 1_10	350	660	1200	3000	4000	15'	10'	90	1200	6500	7500	97	1.33	1.53	1.88	3.24
MP 160 2_9	350	660	1200	1900	3000	15'	10'	83	1200	6500	7500	94	7.51	7.72	8.07	9.42
MP 160 2_12	700	950	1800	1900	3000	15'	10'	83	1200	6500	7500	94	7.10	7.30	7.65	9.01
MP 160 2_15	700	950	1800	1900	3000	15'	10'	83	1200	6500	7500	94	6.94	7.15	7.50	8.85
MP 160 2_16	700	950	1800	2200	3500	15'	10'	83	1200	6500	7500	94	3.95	4.16	4.51	5.86
MP 160 2_20	700	950	1800	2500	3500	15'	10'	83	1200	6500	7500	94	2.82	3.02	3.37	4.73
MP 160 2_25	700	950	1800	2500	3500	15'	10'	83	1200	6500	7500	94	2.76	2.97	3.32	4.67
MP 160 2_28	700	950	1800	3000	4000	15'	10'	83	1200	6500	7500	94	1.79	2.00	2.35	3.70
MP 160 2_30	350	660	1200	3000	4000	15'	10'	83	1200	6500	7500	94	1.25	1.46	1.81	3.16
MP 160 2_35	700	950	1800	3000	4000	15'	10'	83	1200	6500	7500	94	1.77	1.97	2.32	3.68
MP 160 2_36	500	750	1400	2500	3500	15'	10'	83	1200	6500	7500	94	1.06	1.27	1.62	2.97
MP 160 2_40	700	950	1800	3000	4000	15'	10'	83	1200	6500	7500	94	1.21	1.42	1.77	3.12
MP 160 2_50	700	950	1800	3000	4000	15'	10'	83	1200	6500	7500	94	1.20	1.40	1.75	3.11
MP 160 2_70	700	950	1800	3000	4000	15'	10'	83	1200	6500	7500	94	1.18	1.39	1.74	3.09
MP 160 2_100	350	660	1200	3000	4000	15'	10'	83	1200	6500	7500	94	1.18	1.38	1.73	3.09
MP 160 3_48	700	950	1800	2200	3500	17'	12'	60	1200	6500	7500	91	4.10	4.31	4.66	6.01
MP 160 3_64	700	950	1800	2200	3500	17'	12'	60	1200	6500	7500	91	3.90	4.11	4.46	5.81
MP 160 3_75	700	950	1800	2500	3500	17'	12'	60	1200	6500	7500	91	2.91	3.11	3.46	4.82
MP 160 3_80	700	950	1800	2200	3500	17'	12'	60	1200	6500	7500	91	3.90	4.11	4.46	5.81
MP 160 3_84	700	950	1800	3000	4000	17'	12'	60	1200	6500	7500	91	1.84	2.05	2.40	3.75
MP 160 3_90	350	660	1200	3000	4000	17'	12'	60	1200	6500	7500	91	1.24	1.45	1.80	3.15
MP 160 3_120	700	950	1800	3000	4000	17'	12'	60	1200	6500	7500	91	1.23	1.44	1.79	3.14
MP 160 3_125	700	950	1800	2500	3500	17'	12'	60	1200	6500	7500	91	2.74	2.95	3.30	4.65
MP 160 3_140	700	950	1800	3000	4000	17'	12'	60	1200	6500	7500	91	1.78	1.98	2.33	3.69
MP 160 3_150	700	950	1800	3000	4000	17'	12'	60	1200	6500	7500	91	1.23	1.44	1.79	3.14
MP 160 3_160	700	950	1800	3000	4000	17'	12'	60	1200	6500	7500	91	1.20	1.41	1.76	3.11
MP 160 3_175	700	950	1800	3000	4000	17'	12'	60	1200	6500	7500	91	1.76	1.96	2.31	3.67
MP 160 3_200	700	950	1800	3000	4000	17'	12'	60	1200	6500	7500	91	1.20	1.41	1.76	3.11
MP 160 3_210	700	950	1800	3000	4000	17'	12'	60	1200	6500	7500	91	1.23	1.44	1.79	3.14
MP 160 3_250	700	950	1800	3000	4000	17'	12'	60	1200	6500	7500	91	1.19	1.40	1.75	3.10
MP 160 3_280	700	950	1800	3000	4000	17'	12'	60	1200	6500	7500	91	1.18	1.39	1.74	3.09
MP 160 3_350	700	950	1800	3000	4000	17'	12'	60	1200	6500	7500	91	1.18	1.39	1.74	3.09
MP 160 3_400	700	950	1800	3000	4000	17'	12'	60	1200	6500	7500	91	1.18	1.38	1.73	3.09
MP 160 3_500	700	950	1800	3000	4000	17'	12'	60	1200	6500	7500	91	1.18	1.38	1.73	3.09
MP 160 3_700	700	950	1800	3000	4000	17'	12'	60	1200	6500	7500	91	1.18	1.38	1.73	3.09
MP 160 3_1000	350	660	1200	3000	4000	17'	12'	60	1200	6500	7500	91	1.18	1.38	1.73	3.09

MP

Please contact us for different motor adapters and input shaft bore.

MP G 160

55A1 ... 180A1

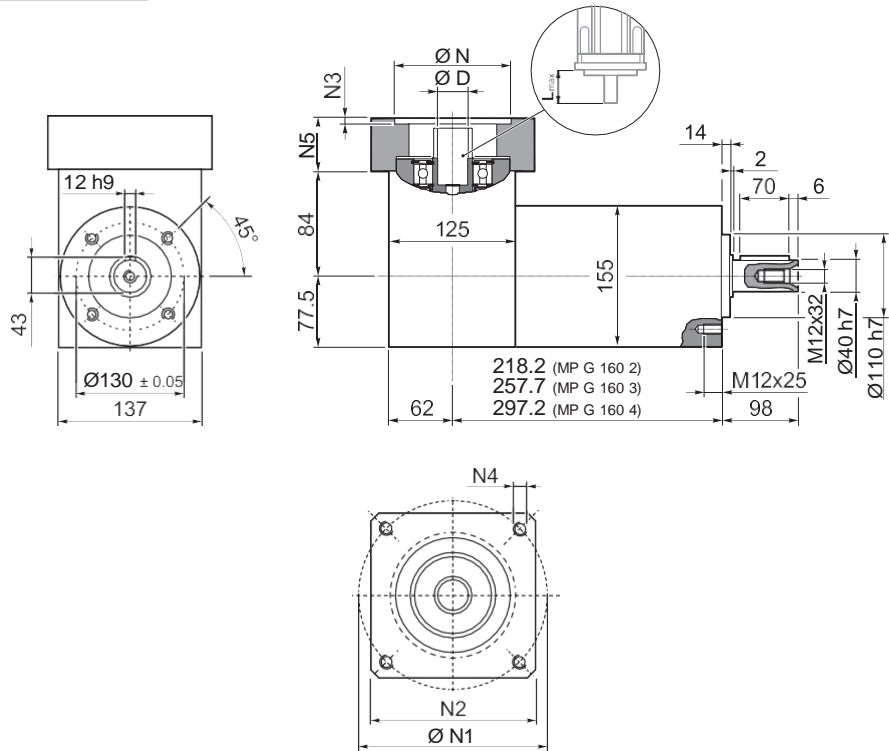

	MP G 160 2	24
	MP G 160 3	28
	MP G 160 4	34

MP

											N	N1	N2	N3	N4	N5	L _{max}
	D																
55A1	14	15.875	16	19	-	-	-	-	-	-	55.5	125.7	140	5	M6x15	39.5	50
80A2	14	15.875	16	19	-	-	-	-	-	-	80	100	140	5	M6x15	39.5	50
95A1	14	15.875	16	19	22	24	-	-	-	-	95	115	140	5	M8x20	39.5	50
110A1	14	15.875	16	19	22	24	-	-	-	-	110	130	140	5	M8x20	39.5	50
110B1	14	15.875	16	19	22	24	-	-	-	-	110	145	140	6.5	M8x20	49.5	60
114A	14	15.875	16	19	22	24	28	32	35	38	114.3	200	170	6.5	M12x25	69.5	80
130A	14	15.875	16	19	22	24	-	-	-	-	130	165	140	5	M10x20	39.5	50
130A1	14	15.875	16	19	22	24	28	32	-	-	130	165	140	5	M10x20	49.5	60
180A	14	15.875	16	19	22	24	28	32	-	-	180	215	190	5.5	M14x25	49.5	60
180A1	14	15.875	16	19	22	24	28	32	35	38	180	215	190	5.5	M14x25	69.5	80

MP G 160

FM

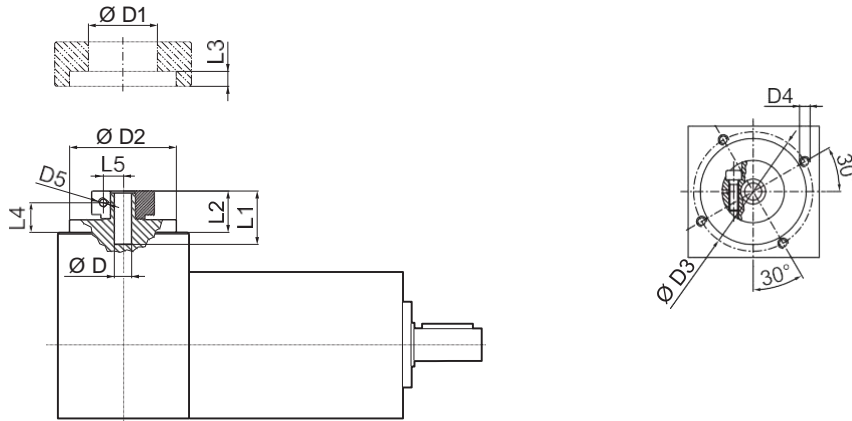

	D1	D2	D3	D4	D5	L1	L2	L3	L4	L5
14 15.875 16	48	113	125.5	M8x15	M6	40	27.5	6	20	14.5
19	51	113	125.5	M8x15	M6	40	27.5	6	20	16.5
22 24	56.5	113	125.5	M8x15	M6	41	28.5	6	19.5	19
28	67	113	125.5	M8x15	M8	41	28.5	6	19.5	22.5
32	71	113	125.5	M8x15	M8	41	28.5	6	19.5	24.5
35	73	113	125.5	M8x15	M8	50	37.5	11.25	26	26
38	77.5	113	125.5	M8x15	M8	50	37.5	11.25	26	28

MP

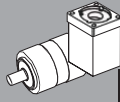
	i	M _{n2} [Nm]	M _{a2} [Nm]	M _{p2} [Nm]	n ₁ [min ⁻¹]	n _{1 max} [min ⁻¹]	φ _S [arcmin]	φ _R [arcmin]	C _t [Nm/arcmin]	R _{2 max} [N]	A _{2 max} [N]	η %	J _G [kgcm ²]			
													14 ... 19	22 - 24	28 - 32	35 - 38
MP G 160 2 3		350	660	1200	1900	3000	15'	10'	90	6500	7500	94	10.23	10.42	10.80	13.51
MP G 160 2 4		500	750	1400	2200	3500	15'	10'	90	6500	7500	94	6.52	6.71	7.09	9.80
MP G 160 2 5		500	750	1400	2500	3500	15'	10'	90	6500	7500	94	5.87	6.06	6.45	9.16
MP G 160 2 6		500	750	1400	2500	3500	15'	10'	90	6500	7500	94	4.58	4.77	5.16	7.86
MP G 160 2 7		500	750	1400	3000	4000	15'	10'	90	6500	7500	94	5.29	5.48	5.87	8.57
MP G 160 2 10		350	660	1200	3000	4000	15'	10'	90	6500	7500	94	4.97	5.16	5.54	8.25
MP G 160 3 9		350	660	1200	1900	3000	15'	10'	83	6500	7500	91	9.35	9.54	9.92	12.63
MP G 160 3 12		700	950	1800	1900	3000	15'	10'	83	6500	7500	91	8.78	8.97	9.36	12.07
MP G 160 3 15		700	950	1800	1900	3000	15'	10'	83	6500	7500	91	8.71	8.90	9.29	11.99
MP G 160 3 16		700	950	1800	2200	3500	15'	10'	83	6500	7500	91	5.79	5.98	6.36	9.07
MP G 160 3 20		700	950	1800	2500	3500	15'	10'	83	6500	7500	91	5.41	6.20	6.59	9.30
MP G 160 3 25		700	950	1800	2500	3500	15'	10'	83	6500	7500	91	5.95	5.54	5.93	8.64
MP G 160 3 28		700	950	1800	3000	4000	15'	10'	83	6500	7500	91	5.05	5.24	5.63	8.33
MP G 160 3 30		350	660	1200	3000	4000	15'	10'	83	6500	7500	91	4.89	5.09	5.47	8.18
MP G 160 3 35		700	950	1800	3000	4000	15'	10'	83	6500	7500	91	5.36	5.54	5.93	8.64
MP G 160 3 36		500	750	1400	2500	3500	15'	10'	83	6500	7500	91	4.32	4.51	4.90	7.60
MP G 160 3 40		700	950	1800	3000	4000	15'	10'	83	6500	7500	91	5.00	5.19	5.58	8.28
MP G 160 3 50		700	950	1800	3000	4000	15'	10'	83	6500	7500	91	4.99	5.18	5.56	8.27
MP G 160 3 70		700	950	1800	3000	4000	15'	10'	83	6500	7500	91	4.82	5.02	5.40	8.11
MP G 160 3 100		350	660	1200	3000	4000	15'	10'	83	6500	7500	91	4.82	5.01	5.39	8.10
MP G 160 4 48		700	950	1800	2200	3500	17'	12'	60	6500	7500	89	5.94	6.13	6.53	9.22
MP G 160 4 64		700	950	1800	2200	3500	17'	12'	60	6500	7500	89	5.74	5.93	6.31	9.02
MP G 160 4 75		700	950	1800	2500	3500	17'	12'	60	6500	7500	89	5.50	5.68	6.07	8.79
MP G 160 4 80		700	950	1800	2200	3500	17'	12'	60	6500	7500	89	5.74	5.93	6.31	9.02
MP G 160 4 84		700	950	1800	3000	4000	17'	12'	60	6500	7500	89	5.10	5.29	5.68	8.38
MP G 160 4 90		350	660	1200	3000	4000	17'	12'	60	6500	7500	89	4.88	5.08	5.46	8.17
MP G 160 4 120		700	950	1800	3000	4000	17'	12'	60	6500	7500	89	4.87	5.07	5.45	8.16
MP G 160 4 125		700	950	1800	2500	3500	17'	12'	60	6500	7500	89	5.33	5.52	5.91	8.62
MP G 160 4 140		700	950	1800	3000	4000	17'	12'	60	6500	7500	89	5.04	5.22	5.61	8.32
MP G 160 4 150		700	950	1800	3000	4000	17'	12'	60	6500	7500	89	4.87	5.07	5.45	8.16
MP G 160 4 160		700	950	1800	3000	4000	17'	12'	60	6500	7500	89	4.84	5.04	5.42	8.13
MP G 160 4 175		700	950	1800	3000	4000	17'	12'	60	6500	7500	89	5.02	5.20	5.59	8.30
MP G 160 4 200		700	950	1800	3000	4000	17'	12'	60	6500	7500	89	4.84	5.04	5.42	8.13
MP G 160 4 210		700	950	1800	3000	4000	17'	12'	60	6500	7500	89	4.87	5.07	5.45	8.16
MP G 160 4 250		700	950	1800	3000	4000	17'	12'	60	6500	7500	89	4.83	5.03	5.41	8.12
MP G 160 4 280		700	950	1800	3000	4000	17'	12'	60	6500	7500	89	4.82	5.02	5.40	8.11
MP G 160 4 350		700	950	1800	3000	4000	17'	12'	60	6500	7500	89	4.82	2.05	5.40	8.11
MP G 160 4 400		700	950	1800	3000	4000	17'	12'	60	6500	7500	89	4.82	5.01	5.39	8.11
MP G 160 4 500		700	950	1800	3000	4000	17'	12'	60	6500	7500	89	4.82	5.01	5.39	8.11
MP G 160 4 700		700	950	1800	3000	4000	17'	12'	60	6500	7500	89	4.82	5.01	5.39	8.11
MP G 160 4 1000		350	660	1200	3000	4000	17'	12'	60	6500	7500	89	4.82	5.01	5.39	8.11

Please contact us for different motor adapters and input shaft bore.

MP MB 160

55A1 ... 180A1

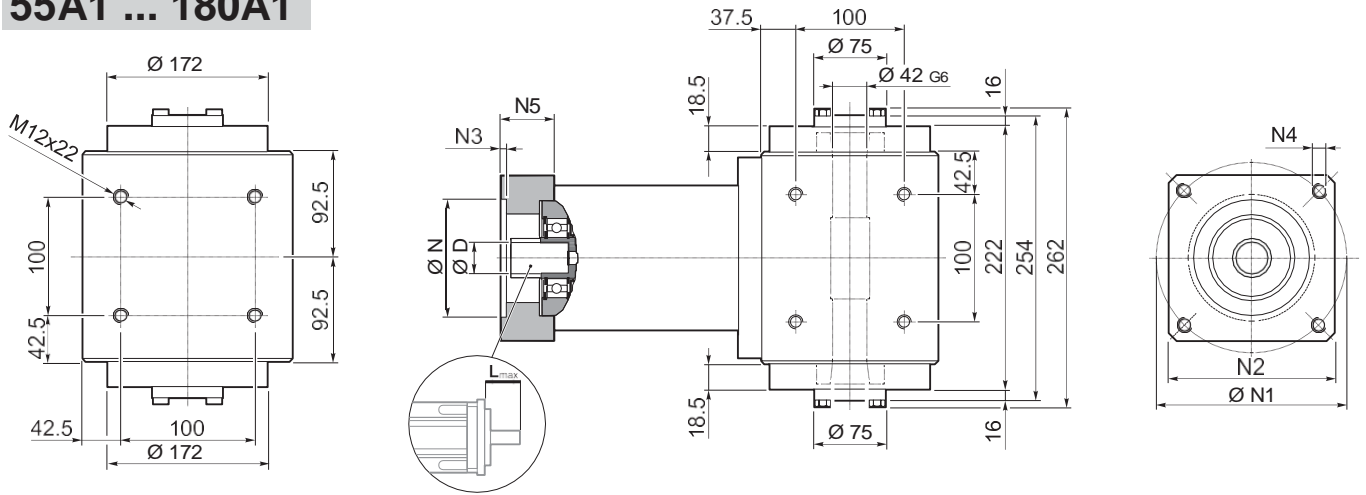

237.5 (MP MB 160 2)
277 (MP MB 160 3)
316.5 (MP MB 160 4)

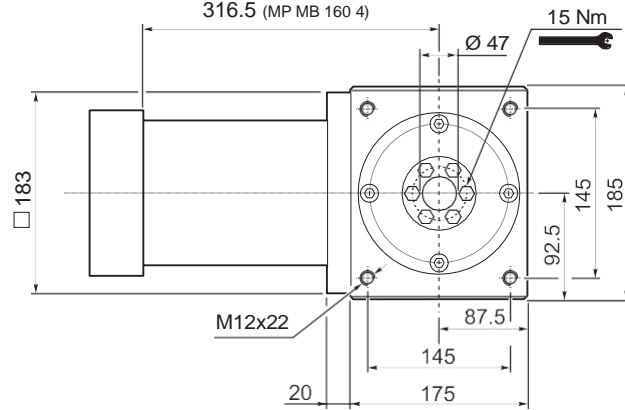

MP MB 160 2	59
MP MB 160 3	63.5
MP MB 160 4	70.5

MP

												N	N1	N2	N3	N4	N5	L _{max}
	14	15.875	16	19														
55A1	14	15.875	16	19	-	-	-	-	-	-	-	55.5	125.7	140	5	M6x15	39.5	50
80A2	14	15.875	16	19	-	-	-	-	-	-	-	80	100	140	5	M6x15	39.5	50
95A1	14	15.875	16	19	22	24	-	-	-	-	-	95	115	140	5	M8x20	39.5	50
110A1	14	15.875	16	19	22	24	-	-	-	-	-	110	130	140	5	M8x20	39.5	50
110B1	14	15.875	16	19	22	24	-	-	-	-	-	110	145	140	6.5	M8x20	49.5	60
114A	14	15.875	16	19	22	24	28	32	35	38	-	114.3	200	170	6.5	M12x25	69.5	80
130A	14	15.875	16	19	22	24	-	-	-	-	-	130	165	140	5	M10x20	39.5	50
130A1	14	15.875	16	19	22	24	28	32	-	-	-	130	165	140	5	M10x20	49.5	60
180A	14	15.875	16	19	22	24	28	32	-	-	-	180	215	190	5.5	M14x25	49.5	60
180A1	14	15.875	16	19	22	24	28	32	35	38	-	180	215	190	5.5	M14x25	69.5	80

MP MB 160

FM

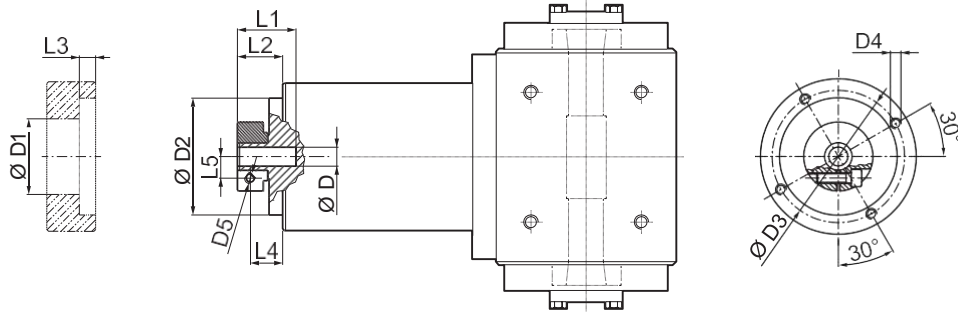

			D1	D2	D3	D4	D5	L1	L2	L3	L4	L5
14	15.875	16	48	130	142.5	M8x16	M6	40	27.5	6	20	14.5
19			51	130	142.5	M8x16	M6	40	27.5	6	20	16.5
22	24		56.5	130	142.5	M8x16	M6	41	28.5	6	19.5	19
28			67	130	142.5	M8x16	M8	41	28.5	6	19.5	22.5
32			71	130	142.5	M8x16	M8	41	28.5	6	19.5	24.5
35			73	130	142.5	M8x16	M8	50	37.5	11.25	26	26
38			77.5	130	142.5	M8x16	M8	50	37.5	11.25	26	28

	i	M _{n 2} [Nm]	M _{a 2} [Nm]	M _{p 2} [Nm]	n ₁ [min ⁻¹]	n _{1 max} [min ⁻¹]	φ _S [arcmin]	φ _R [arcmin]	C _t [Nm/arcmin]	η %	J _G [kgcm ²]				
												14 ... 19	22 - 24	28 - 32	35 - 38
MP MB 160 2 3		350	660	1200	1900	3000	15'	10'	90	94	8.39	8.60	8.95	10.30	
MP MB 160 2 4		500	750	1400	2200	3500	15'	10'	90	94	4.68	4.89	5.24	6.59	
MP MB 160 2 5		500	750	1400	2500	3500	15'	10'	90	94	3.28	3.49	3.84	5.19	
MP MB 160 2 6		500	750	1400	2500	3500	15'	10'	90	94	1.32	1.53	1.88	3.23	
MP MB 160 2 7		500	750	1400	3000	4000	15'	10'	90	94	2.03	2.24	2.59	3.94	
MP MB 160 2 10		350	660	1200	3000	4000	15'	10'	90	94	1.33	1.53	1.88	3.24	
MP MB 160 3 9		350	660	1200	1900	3000	15'	10'	83	91	7.51	7.72	8.07	9.42	
MP MB 160 3 12		700	950	1800	1900	3000	15'	10'	83	91	7.10	7.30	7.65	9.01	
MP MB 160 3 15		700	950	1800	1900	3000	15'	10'	83	91	6.94	7.15	7.50	8.85	
MP MB 160 3 16		700	950	1800	2200	3500	15'	10'	83	91	3.95	4.16	4.51	5.86	
MP MB 160 3 20		700	950	1800	2500	3500	15'	10'	83	91	2.82	3.02	3.37	4.73	
MP MB 160 3 25		700	950	1800	2500	3500	15'	10'	83	91	2.76	2.97	3.32	4.67	
MP MB 160 3 28		700	950	1800	3000	4000	15'	10'	83	91	1.79	2.00	2.35	3.70	
MP MB 160 3 30		350	660	1200	3000	4000	15'	10'	83	91	1.25	1.46	1.81	3.16	
MP MB 160 3 35		700	950	1800	3000	4000	15'	10'	83	91	1.77	1.97	2.32	3.68	
MP MB 160 3 36		500	750	1400	2500	3500	15'	10'	83	91	1.06	1.27	1.62	2.97	
MP MB 160 3 40		700	950	1800	3000	4000	15'	10'	83	91	1.21	1.42	1.77	3.12	
MP MB 160 3 50		700	950	1800	3000	4000	15'	10'	83	91	1.20	1.40	1.75	3.11	
MP MB 160 3 70		700	950	1800	3000	4000	15'	10'	83	91	1.18	1.39	1.74	3.09	
MP MB 160 3 100		350	660	1200	3000	4000	15'	10'	83	91	1.18	1.38	1.73	3.09	
MP MB 160 4 48		700	950	1800	2200	3500	17'	12'	60	89	4.10	4.31	4.66	6.01	
MP MB 160 4 64		700	950	1800	2200	3500	17'	12'	60	89	3.90	4.11	4.46	5.81	
MP MB 160 4 75		700	950	1800	2500	3500	17'	12'	60	89	2.91	3.11	3.46	4.82	
MP MB 160 4 80		700	950	1800	2200	3500	17'	12'	60	89	3.90	4.11	4.46	5.81	
MP MB 160 4 84		700	950	1800	3000	4000	17'	12'	60	89	1.84	2.05	2.40	3.75	
MP MB 160 4 90		350	660	1200	3000	4000	17'	12'	60	89	1.24	1.45	1.80	3.15	
MP MB 160 4 120		700	950	1800	3000	4000	17'	12'	60	89	1.23	1.44	1.79	3.14	
MP MB 160 4 125		700	950	1800	2500	3500	17'	12'	60	89	2.74	2.95	3.30	4.65	
MP MB 160 4 140		700	950	1800	3000	4000	17'	12'	60	89	1.78	1.98	2.33	3.69	
MP MB 160 4 150		700	950	1800	3000	4000	17'	12'	60	89	1.23	1.44	1.79	3.14	
MP MB 160 4 160		700	950	1800	3000	4000	17'	12'	60	89	1.20	1.41	1.76	3.11	
MP MB 160 4 175		700	950	1800	3000	4000	17'	12'	60	89	1.76	1.96	2.31	3.67	
MP MB 160 4 200		700	950	1800	3000	4000	17'	12'	60	89	1.20	1.41	1.76	3.11	
MP MB 160 4 210		700	950	1800	3000	4000	17'	12'	60	89	1.23	1.44	1.79	3.14	
MP MB 160 4 250		700	950	1800	3000	4000	17'	12'	60	89	1.19	1.40	1.75	3.10	
MP MB 160 4 280		700	950	1800	3000	4000	17'	12'	60	89	1.18	1.39	1.74	3.09	
MP MB 160 4 350		700	950	1800	3000	4000	17'	12'	60	89	1.18	1.39	1.74	3.09	
MP MB 160 4 400		700	950	1800	3000	4000	17'	12'	60	89	1.18	1.38	1.73	3.09	
MP MB 160 4 500		700	950	1800	3000	4000	17'	12'	60	89	1.18	1.38	1.73	3.09	
MP MB 160 4 700		700	950	1800	3000	4000	17'	12'	60	89	1.18	1.38	1.73	3.09	
MP MB 160 4 1000		350	660	1200	3000	4000	17'	12'	60	89	1.18	1.38	1.73	3.09	

MP

Please contact us for different motor adapters and input shaft bore.

MP 190

55A1 ... 180A1

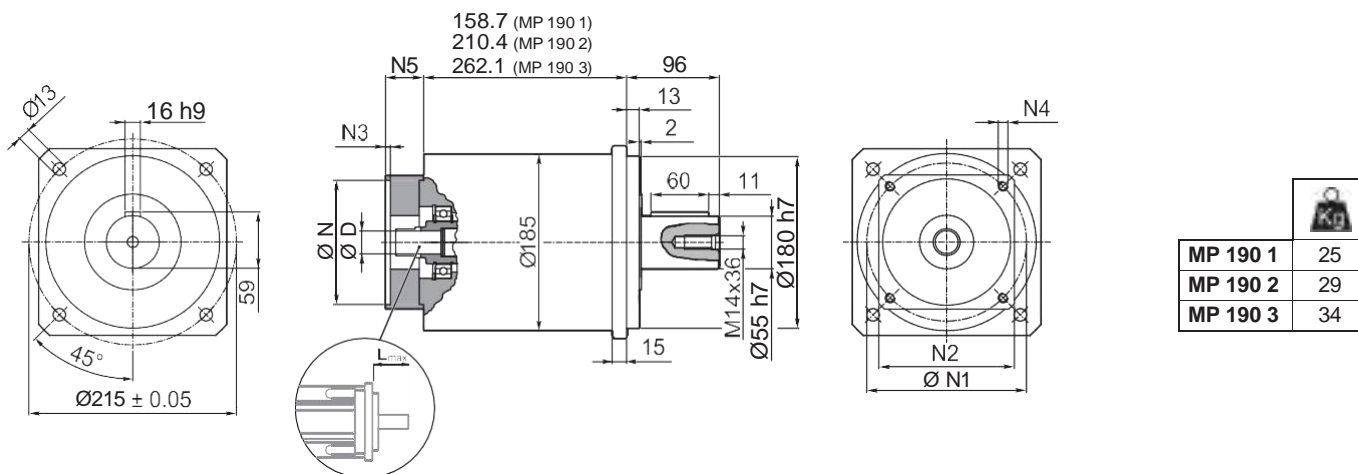

MP

	D												N	N1	N2	N3	N4	N5	L _{max}	
55A1	14	16	19	-	-	-	-	-	-	-	-	-	-	55.5	125.7	140	5	M6x15	39.5	50
80A2	14	16	19	-	-	-	-	-	-	-	-	-	-	80	100	140	5	M6x15	39.5	50
95A1	14	16	19	22	24	-	-	-	-	-	-	-	-	95	115	140	5	M8x20	39.5	50
110A1	14	16	19	22	24	-	-	-	-	-	-	-	-	110	130	140	5	M8x20	39.5	50
110B1	14	16	19	22	24	-	-	-	-	-	-	-	-	110	145	140	6.5	M8x20	49.5	60
114A	14	16	19	22	24	28	32	35	38	42	45	48	114.3	200	170	6.5	M12x25	69.5	80	
130A	14	16	19	22	24	-	-	-	-	-	-	-	130	165	140	5	M10x20	39.5	50	
130A1	14	16	19	22	24	28	32	-	-	-	-	-	130	165	140	5	M10x20	49.5	60	
180A	14	16	19	22	24	28	32	-	-	-	-	-	180	215	190	5.5	M14x25	49.5	60	
180A1	14	16	19	22	24	28	32	35	38	42	45	48	180	215	190	5.5	M14x25	69.5	80	

Please contact us for different motor adapters and input shaft bore.

FM

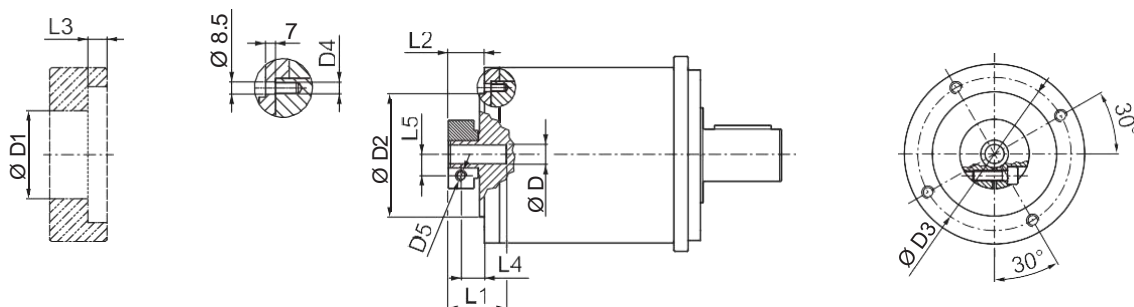

D		D1	D2	D3	D4	D5	L1	L2	L3	L4	L5
14	16	48	130	142.5	M8x14	M6	45.5	27.5	6	20	14.5
19		51	130	142.5	M8x14	M6	45.5	27.5	6	20	16.5
22	24	56.5	130	142.5	M8x14	M6	47	29	6	20	19
28		67	130	142.5	M8x14	M8	47	29	6	20	22.5
32		71	130	142.5	M8x14	M8	47	29	6	20	24.5
35		73	130	142.5	M8x14	M8	54.5	36.5	6	25	26
38		77.5	130	142.5	M8x14	M8	54.5	36.5	6	25	28
42		92	130	142.5	M8x14	M10	60.5	40	6	25	33
45		95	130	142.5	M8x14	M10	60.5	40	6	25	33
48		97	130	142.5	M8x14	M10	60.5	40	6	25	33

MP 190

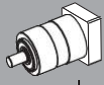
 i	M_{n2}	M_{a2}	M_{p2}	n_1	$n_{1\max}$	ϕ_S	ϕ_R	C_t	$R_{2\max}$	$A_{2\max}$	η	J_G [kgcm ²]				
	[Nm]	[Nm]	[Nm]	[min ⁻¹]	[min ⁻¹]	[arcmin]	[$\frac{Nm}{arcmin}$]	[N]	[N]	%	14 ... 24	28 - 32	35 - 35	42	45 - 48	
MP 190 1_3	500	800	1400	1500	2500	15'	10'	130	14000	15000	97	24.20	24.88	25.65	29.30	29.90
MP 190 1_4	700	950	1800	2100	3000	15'	10'	130	14000	15000	97	13.41	14.09	14.85	18.51	19.11
MP 190 1_5	700	950	1800	2300	3000	15'	10'	130	14000	15000	97	9.32	10.00	10.77	14.42	15.02
MP 190 1_6	700	950	1800	2300	3000	15'	10'	130	14000	15000	97	2.88	3.56	4.33	7.98	8.58
MP 190 1_7	700	950	1800	2900	3500	15'	10'	130	14000	15000	97	5.68	6.36	7.13	10.78	11.38
MP 190 1_10	500	800	1400	2900	3500	15'	10'	130	14000	15000	97	3.57	4.25	5.02	8.67	9.27
MP 190 2_9	500	800	1400	1500	2500	15'	10'	100	14000	15000	94	23.23	23.91	24.67	28.33	28.93
MP 190 2_12	1000	1200	2200	1500	2500	15'	10'	100	14000	15000	94	22.03	22.71	23.48	27.13	27.73
MP 190 2_15	1000	1200	2200	1500	2500	15'	10'	100	14000	15000	94	21.58	22.25	23.02	26.68	27.27
MP 190 2_16	1000	1200	2200	2100	3000	15'	10'	100	14000	15000	94	12.19	12.86	13.63	17.29	17.89
MP 190 2_20	1000	1200	2200	2300	3000	15'	10'	100	14000	15000	94	8.54	9.22	9.98	13.64	14.24
MP 190 2_25	1000	1200	2200	2300	3000	15'	10'	100	14000	15000	94	8.37	9.05	9.82	13.48	14.07
MP 190 2_28	1000	1200	2200	2900	3500	15'	10'	100	14000	15000	94	5.28	5.96	6.73	10.38	10.98
MP 190 2_30	500	800	1400	2900	3500	15'	10'	100	14000	15000	94	3.48	4.16	4.93	8.58	9.18
MP 190 2_35	1000	1200	2200	2900	3500	15'	10'	100	14000	15000	94	5.20	5.87	6.64	10.30	10.90
MP 190 2_36	700	950	1800	2300	3000	15'	10'	100	14000	15000	94	2.18	2.86	3.63	7.28	7.88
MP 190 2_40	1000	1200	2200	2900	3500	15'	10'	100	14000	15000	94	3.37	4.05	4.82	8.48	9.07
MP 190 2_50	1000	1200	2200	2900	3500	15'	10'	100	14000	15000	94	3.33	4.01	4.78	8.44	9.03
MP 190 2_70	1000	1200	2200	2900	3500	15'	10'	100	14000	15000	94	3.30	3.97	4.74	8.40	9.00
MP 190 2_100	500	800	1400	2900	3500	15'	10'	100	14000	15000	94	3.28	3.95	4.72	8.38	8.98
MP 190 3_48	1000	1200	2200	2100	3000	17'	12'	90	14000	15000	91	12.73	13.40	14.17	17.83	18.43
MP 190 3_64	1000	1200	2200	2100	3000	17'	12'	90	14000	15000	91	12.10	12.78	13.55	17.21	17.80
MP 190 3_75	1000	1200	2200	2300	3000	17'	12'	90	14000	15000	91	8.86	9.54	10.31	13.97	14.56
MP 190 3_80	1000	1200	2200	2100	3000	17'	12'	90	14000	15000	91	12.09	12.76	13.53	17.19	17.79
MP 190 3_84	1000	1200	2200	2900	3500	17'	12'	90	14000	15000	91	5.46	6.13	6.90	10.56	11.16
MP 190 3_90	500	800	1400	2900	3500	17'	12'	90	14000	15000	91	3.47	4.15	4.92	8.57	9.17
MP 190 3_120	1000	1200	2200	2900	3500	17'	12'	90	14000	15000	91	3.46	4.14	4.91	8.56	9.16
MP 190 3_125	1000	1200	2200	2300	3000	17'	12'	90	14000	15000	91	8.34	9.01	9.78	13.44	14.04
MP 190 3_140	1000	1200	2200	2900	3500	17'	12'	90	14000	15000	91	5.25	5.92	6.69	10.35	10.95
MP 190 3_150	1000	1200	2200	2900	3500	17'	12'	90	14000	15000	91	3.46	4.13	4.90	8.56	9.15
MP 190 3_160	1000	1200	2200	2900	3500	17'	12'	90	14000	15000	91	3.36	4.04	4.81	8.46	9.06
MP 190 3_175	1000	1200	2200	2900	3500	17'	12'	90	14000	15000	91	5.18	5.85	6.62	10.28	10.88
MP 190 3_200	1000	1200	2200	2900	3500	17'	12'	90	14000	15000	91	3.36	4.03	4.80	8.46	9.06
MP 190 3_210	1000	1200	2200	2900	3500	17'	12'	90	14000	15000	91	3.45	4.13	4.90	8.55	9.15
MP 190 3_250	1000	1200	2200	2900	3500	17'	12'	90	14000	15000	91	3.32	4.00	4.77	8.42	9.02
MP 190 3_280	1000	1200	2200	2900	3500	17'	12'	90	14000	15000	91	3.29	3.97	4.74	8.39	8.99
MP 190 3_350	1000	1200	2200	2900	3500	17'	12'	90	14000	15000	91	3.29	3.97	4.74	8.39	8.99
MP 190 3_400	1000	1200	2200	2900	3500	17'	12'	90	14000	15000	91	3.27	3.95	4.72	8.38	8.97
MP 190 3_500	1000	1200	2200	2900	3500	17'	12'	90	14000	15000	91	3.27	3.95	4.72	8.38	8.97
MP 190 3_700	1000	1200	2200	2900	3500	17'	12'	90	14000	15000	91	3.27	3.95	4.72	8.38	8.97
MP 190 3_1000	500	800	1400	2900	3500	17'	12'	90	14000	15000	91	3.27	3.95	4.72	8.38	8.97

6.3.1 MACHINE SHAFT

Shaft of driven equipment should be made from high grade alloy steel. Table below shows recommended dimensions for the Customer to consider when designing mating shaft. A device retaining the shaft axially is also recommended (not shown). The number and size of relative tapped holes at shaft end depend on application requirements.

MB

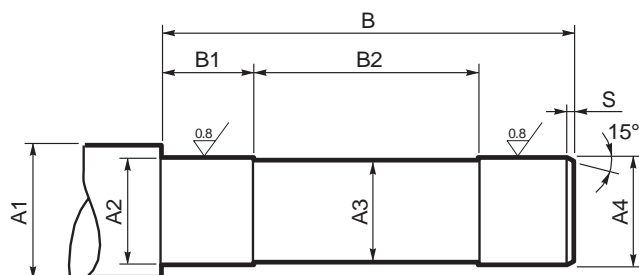

	A1	A2	A3	A4	B	B1	B2	S
MP MB 080	≥ 25	20 h7	18	20 h7	178	50	90	1
MP MB 105	≥ 40	32 h7	30	32 h7	205	60	115	
MP MB 130/160	≥ 50	42 h7	40	42 h7	259	70	140	

MP



TQFE Series

The TQFE series combines exceptional compactness with a standardized flange interface, ensuring a quick and easy mounting suitable for a wide variety of applications. With TQFE it is possible to have high levels of performance and precision at an optimum value-price ratio.

Main benefits

- High torsional stiffness
- High compactness
- Easy and quick installation
- Standardized flange for great compatibility

Main features

- Nominal output torque (Nm)
 - 18 - 155
- Torsional backlash (arcmin)
 - 5 - 12
- Torsional stiffness (Nm/arcmin)
 - 6 - 60
- Max tilting moment (Nm)
 - 12 - 110

Main options

- Input versions
 - MOTOR ADAPTER
 - SOLID INPUT SHAFT
 - WITHOUT MOTOR ADAPTER
- Lubrication
 - STANDARD LUBRICATION
 - UH1 FOOD GRADE LUBRICATION

Protection class

- IP54

Frame sizes

- 060
- 070
- 090

7 FEATURES OF TQFE SERIES

The TQFE Series represents the answer for applications requiring compact, space-saving solutions. Its standardized flange ensures great compatibility while its proportioned design allows quiet running and provides a long service life without maintenance requirements. Motor mounting is an operation that can be easily conducted without the need of any particular tooling, other than that usually available in a normally equipped workshop.

- Available with either standard (STD) or reduced (LOW) backlash:
 - 1-stage units: standard $\phi_S \leq 10'$; reduced $\phi_R \leq 5'$
 - 2-stage units: standard $\phi_S \leq 12'$; reduced $\phi_R \leq 7'$
- Its degree of protection IP54 provides protection against dust and liquid splashes.
- Input section oil seals made from a Fluoroelastomer compound are supplied as standard.
- Noise pressure level LP ≤ 70 dB(A). Conditions: distance 1 m; measured without load an input speed of $n_1 = 3000 \text{ min}^{-1}$; $i=10$.
- Units are factory packed with synthetic grease to NLGI consistency class 00, in the absence of contamination the lubricant requires no periodical changes.
- Ambient temperature min -20°C , max $+30^\circ\text{C}$. For temperature higher than 30°C please consider derating factor f_T .
- Housing temperature must not exceed $T_{\text{max}} = 90^\circ\text{C}$.

		Distribution of nominal torque M_{n2} [Nm]																	
	[i]	3	4	5	7	9	10	12	15	16	20	25	28	30	35	40	50	70	100
TQFE 060		29	30	25	25	29	18	29	29	30	30	30	29	30	30	30	30	18	
TQFE 070		65	60	50	50	65	40	65	65	60	60	50	50	65	50	60	50	50	40
TQFE 090		155	155	125	125	155	100	155	155	155	155	125	125	155	125	155	125	125	100

TQFE

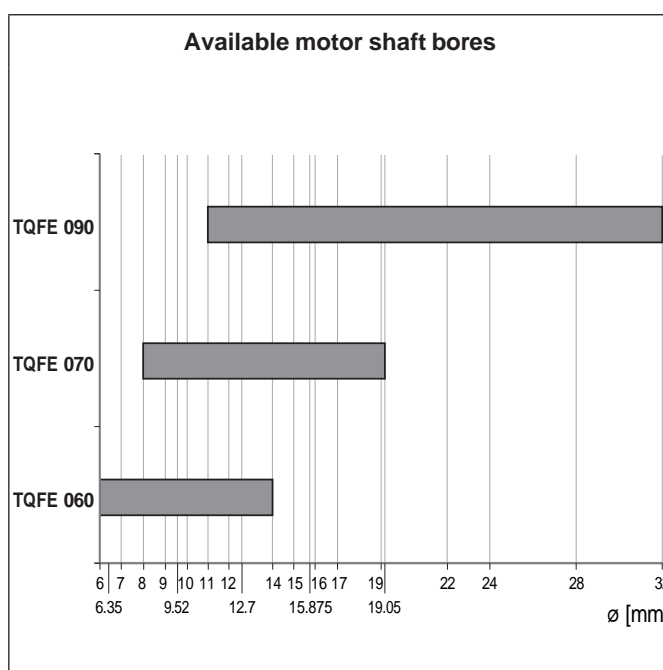
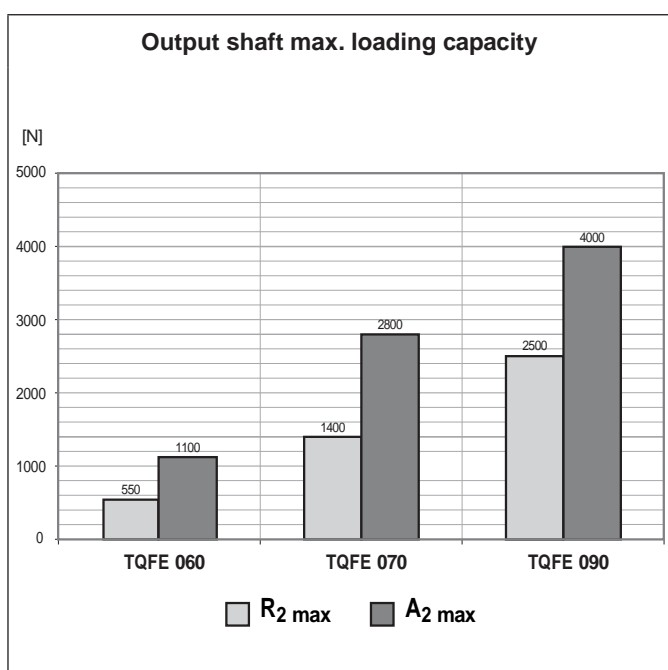

7.1 ORDERING CODE

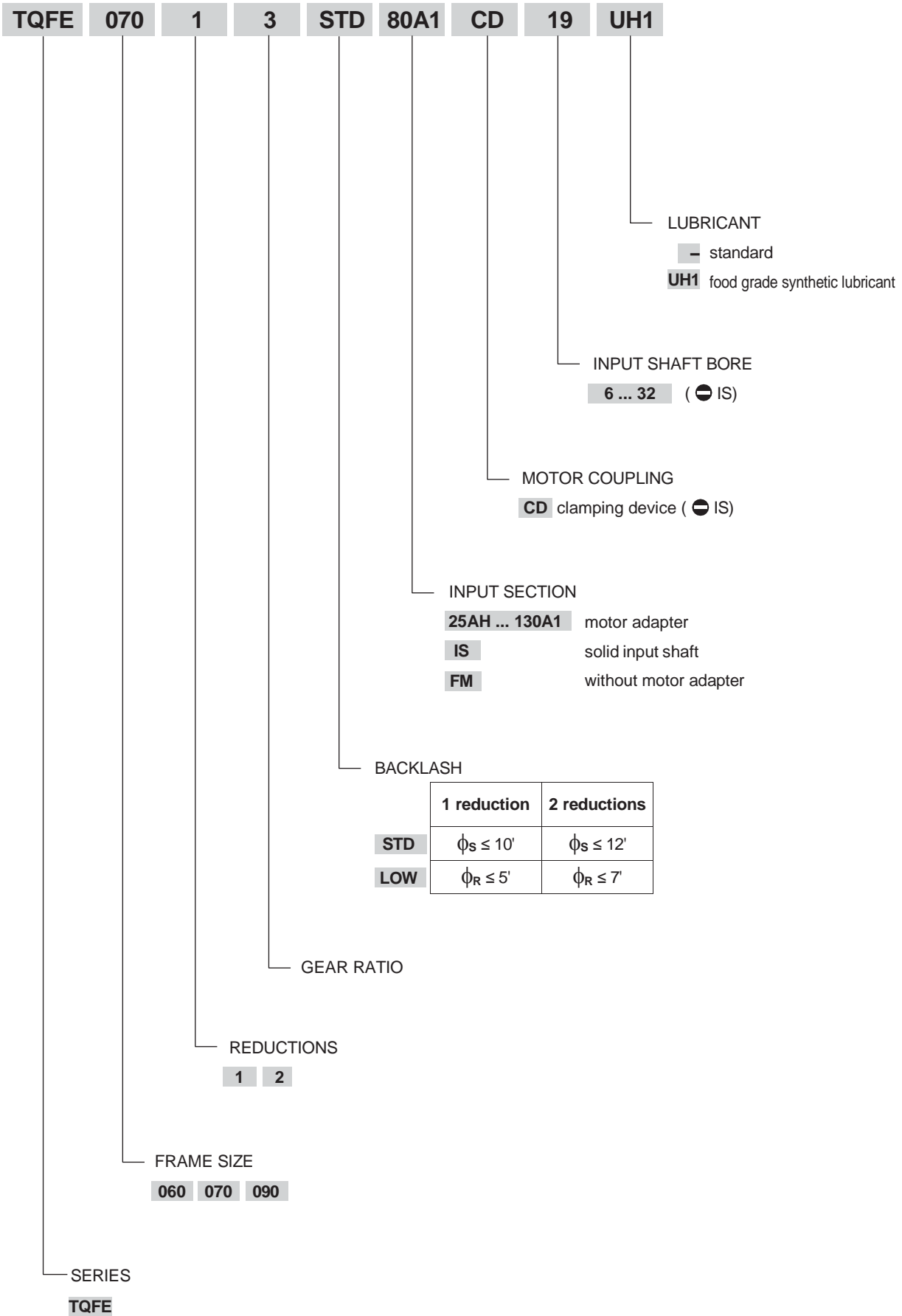

7.2 DIMENSIONS AND TECHNICAL SPECIFICATIONS

TQFE 060

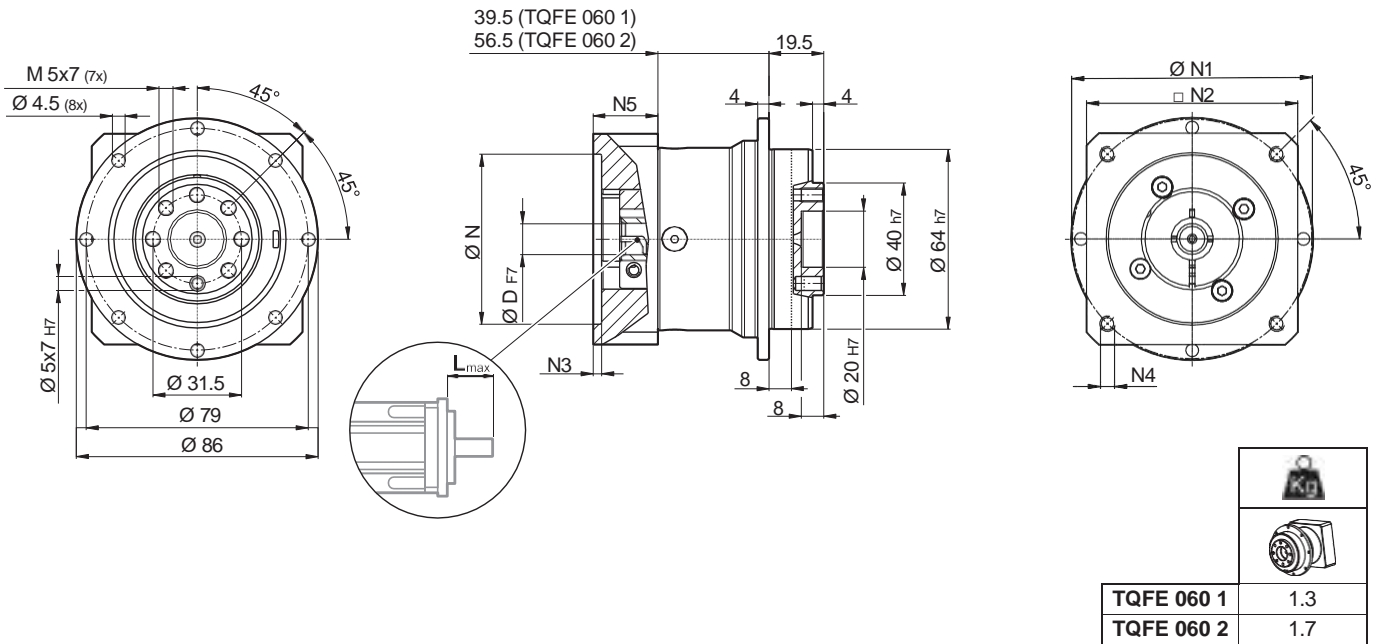

TQFE

	D											N	N1		N2	N3	N4	N5	L _{max}
	6	6.35	7	8	9	9.52	-	-	-	-	-		min	max					
25AH	6	6.35	7	8	9	9.52	-	-	-	-	-	25	39	56					
26AH	6	6.35	7	8	9	9.52	-	-	-	-	-	26	39	56					
28AH	6	6.35	7	8	9	9.52	-	-	-	-	-	28	39	56					
30AH	6	6.35	7	8	9	9.52	-	-	-	-	-	30	39	56					
32AH	6	6.35	7	8	9	9.52	-	-	-	-	-	32	39	56	65	3.5	4.5	25	25
34AH	6	6.35	7	8	9	9.52	-	-	-	-	-	34	40	56					
36AH	6	6.35	7	8	9	9.52	-	-	-	-	-	36	42	56					
39AH	6	6.35	7	8	9	9.52	-	-	-	-	-	39	45	56					
40AH	6	6.35	7	8	9	9.52	-	-	-	-	-	40	46	56					
38B	6	6.35	7	8	9	9.52	10	11	12	12.7	-	38.1	66.6	60	3	M4x10	18	25	
40B	6	6.35	7	8	9	9.52	10	11	12	12.7	-	40	63	60	3	M4x10	18	25	
50A	6	6.35	7	8	9	9.52	10	11	12	12.7	-	50	60	60	3	M4x10	18	25	
50B	6	6.35	7	8	9	9.52	10	11	12	12.7	14	50	65	60	3	M5x12	23	30	
50BH	6	6.35	7	8	9	9.52	10	11	12	12.7	14	50	65	65	3	5.5	25	32	
50C	6	6.35	7	8	9	9.52	10	11	12	12.7	14	50	70	60	3	M4x10	23	30	
55MH	6	6.35	7	8	9	9.52	10	11	12	12.7	-	55	80	65	2	5.5	16	23	
60A	6	6.35	7	8	9	9.52	10	11	12	12.7	-	60	75	65	3	M5x12	18	25	
60AH	6	6.35	7	8	9	9.52	10	11	12	12.7	-	60	75	65	3	5.5	18	25	
60A1	6	6.35	7	8	9	9.52	10	11	12	12.7	14	60	75	65	3	M5x12	23	30	
60AH1	6	6.35	7	8	9	9.52	10	11	12	12.7	14	60	75	65	3	5.5	23	30	
60B	6	6.35	7	8	9	9.52	10	11	12	12.7	14	60	85	75	3	M5x12	23	30	
60C	6	6.35	7	8	9	9.52	10	11	12	12.7	14	60	90	75	3	M5x12	23	30	
70A	6	6.35	7	8	9	9.52	10	11	12	12.7	14	70	85	75	3	M6x15	23	30	
70B	6	6.35	7	8	9	9.52	10	11	12	12.7	14	70	90	75	3	M5x12	23	30	
73A	6	6.35	7	8	9	9.52	10	11	12	12.7	14	73	98.4	85	3	M5x12	25	32	
80A	6	6.35	7	8	9	9.52	10	11	12	12.7	14	80	100	85	3	M6x15	23	30	

TQFE 060

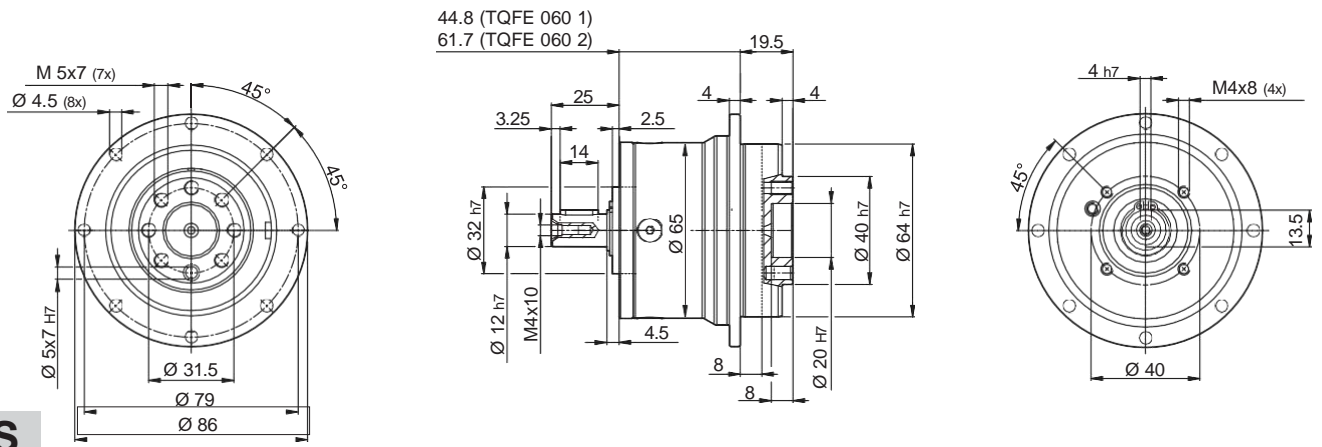

IS

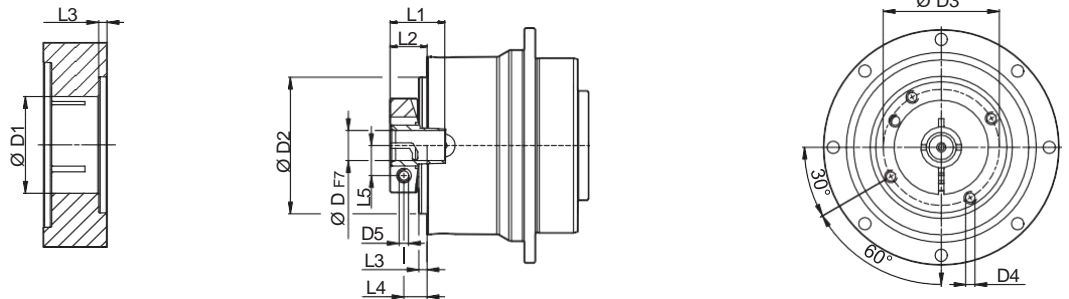

FM

TQFE

				D1	D2	D3	D4	D5	L1	L2	L3	L4	L5
6	6.35	7		32.5	50	42.5	M4x8	M4	21.7	13.2	3	8.2	8
8	9	9.52	10	32.5	50	42.5	M4x8	M4	21.7	13.2	3	8.2	9
11	12	12.7		35.5	50	42.5	M4x8	M4	22	13.5	3	8.5	11
14				35.5	50	42.5	M4x8	M4	25	17	3	10.2	11.5

	i	M _{n 2} [Nm]	M _{a 2} [Nm]	M _{p 2} [Nm]	n ₁ [min ⁻¹]	n _{1 max} [min ⁻¹]	φ _S [arcmin]	φ _R [arcmin]	C _t [mm]	R _{1 max} [N]	R _{2 max} [N]	A _{2 max} [N]	η %	J _G [kgcm ²]	
														6 ... 10	11 ... 14
TQFE 060 1_3		29	55	60	3300	4000	10'	5'	6.5	200	550	1100	97	0.21	0.25
TQFE 060 1_4		30	45	70	3500	5000	10'	5'	6.5	200	550	1100	97	0.18	0.20
TQFE 060 1_5		25	40	70	3500	5000	10'	5'	6.5	200	550	1100	97	0.16	0.18
TQFE 060 1_7		25	40	70	4000	5000	10'	5'	6.5	200	550	1100	97	0.13	0.14
TQFE 060 1_10		18	30	60	4000	6000	10'	5'	6.5	200	550	1100	97	0.12	0.12
TQFE 060 2_9		29	55	60	3300	4000	12'	7'	6	200	550	1100	94	0.18	0.21
TQFE 060 2_12		29	55	70	3300	4000	12'	7'	6	200	550	1100	94	0.17	0.21
TQFE 060 2_15		29	55	70	3300	4000	12'	7'	6	200	550	1100	94	0.17	0.20
TQFE 060 2_16		30	45	70	3500	5000	12'	7'	6	200	550	1100	94	0.13	0.15
TQFE 060 2_20		30	45	70	3500	5000	12'	7'	6	200	550	1100	94	0.13	0.14
TQFE 060 2_25		30	45	70	3500	5000	12'	7'	6	200	550	1100	94	0.12	0.14
TQFE 060 2_28		30	45	70	4000	6000	12'	7'	6	200	550	1100	94	0.11	0.13
TQFE 060 2_30		29	55	60	4000	6000	12'	7'	6	200	550	1100	94	0.10	0.12
TQFE 060 2_35		30	45	70	4000	6000	12'	7'	6	200	550	1100	94	0.08	0.11
TQFE 060 2_40		30	45	70	4000	6000	12'	7'	6	200	550	1100	94	0.08	0.09
TQFE 060 2_50		30	45	70	4000	6000	12'	7'	6	200	550	1100	94	0.07	0.09
TQFE 060 2_70		30	45	70	4000	6000	12'	7'	6	200	550	1100	94	0.06	0.09
TQFE 060 2_100		18	30	60	4000	6000	12'	7'	6	200	550	1100	94	0.06	0.09

Please contact us for different motor adapters and input shaft bore.

TQFE 070

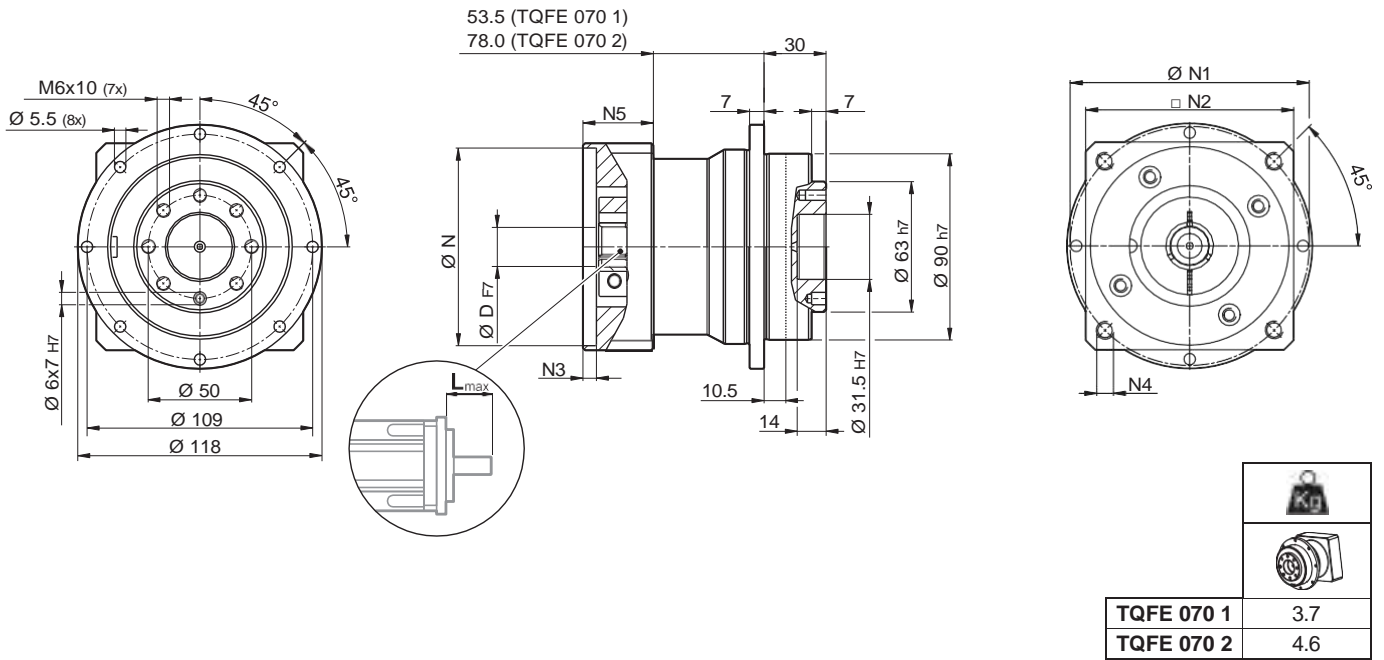

TQFE

												N	N1	N2	N3	N4	N5	L _{max}	
40B1	8	9	9.52	11	12	12.7	14	-	-	-	-	40	63	80	4	M4x12	34	40	
45A	8	9	9.52	11	12	12.7	-	-	-	-	-	45	63	80	4	M4x12	34	40	
50B1	8	9	9.52	11	12	12.7	14	-	-	-	-	50	65	80	4	M5x16	34	40	
50BH1	8	9	9.52	11	12	12.7	14	-	-	-	-	50	65	80	4	5.5	34	40	
50C1	8	9	9.52	11	12	12.7	14	-	-	-	-	50	70	80	4	M4x10	34	40	
50D	8	9	9.52	11	12	12.7	14	-	-	-	-	50	95	80	4	M6x20	34	40	
55A	8	9	9.52	11	12	12.7	14	15.875	16	17	19	19.05	55.5	125.7	105	4	M6x20	34	40
60A2	8	9	9.52	11	12	12.7	14	-	-	-	-	60	75	80	4	M5x16	34	40	
60AH2	8	9	9.52	11	12	12.7	14	-	-	-	-	60	75	90	4	6.5	34	40	
60B1	8	9	9.52	11	12	12.7	14	15.875	16	-	-	60	85	80	4	M5x16	34	40	
60C1	8	9	9.52	11	12	12.7	14	15.875	16	-	-	60	90	80	4	M5x16	34	40	
70A1	8	9	9.52	11	12	12.7	14	15.875	16	17	19	19.05	70	85	80	4	M6x20	34	40
70AH1	8	9	9.52	11	12	12.7	14	15.875	16	17	19	19.05	70	85	90	4	6.5	34	40
70B1	8	9	9.52	11	12	12.7	14	15.875	16	17	19	19.05	70	90	80	4	M5x16	34	40
73A1	8	9	9.52	11	12	12.7	14	-	-	-	-	73	98.4	85	4	M5x16	34	40	
80A1	8	9	9.52	11	12	12.7	14	15.875	16	17	19	19.05	80	100	90	4	M6x16	34	40
95A	8	9	9.52	11	12	12.7	14	15.875	16	17	19	19.05	95	115	100	4	M8x20	34	40
95B	8	9	9.52	11	12	12.7	14	15.875	16	17	19	19.05	95	130	115	4	M8x20	34	40
110A	8	9	9.52	11	12	12.7	14	15.875	16	17	19	19.05	110	130	115	4	M8x20	34	40
110B	8	9	9.52	11	12	12.7	14	15.875	16	17	19	19.05	110	145	120	6.5	M8x20	44	50
110B1	8	9	9.52	11	12	12.7	14	15.875	16	17	19	19.05	110	145	120	6.5	M8x20	54	60

TQFE 070

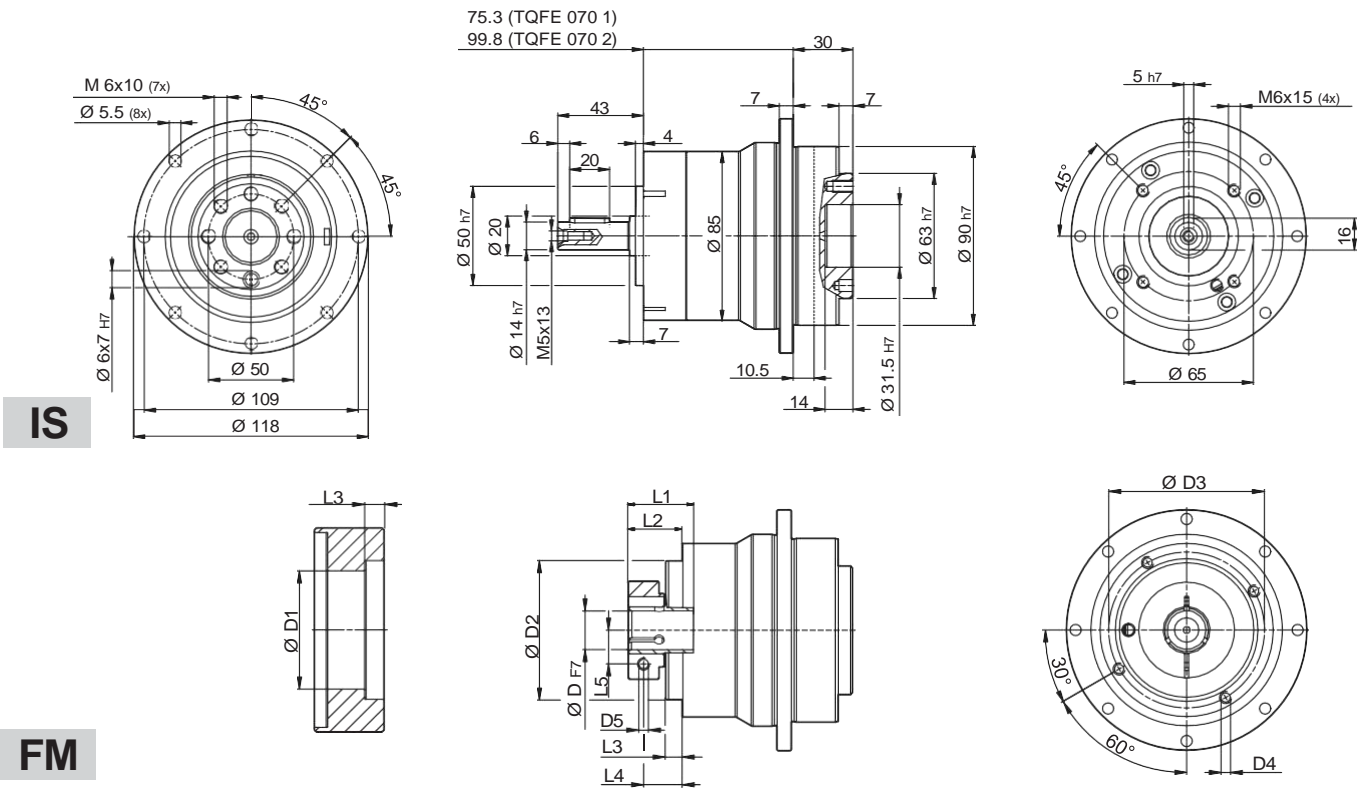

IS

FM

TQFE

D				D1	D2	D3	D4	D5	L1	L2	L3	L4	L5
8	9	9.52		38	68	76.5	M6x10	M6	34	26.8	9.5	18.8	10.5
11	12	12.7		52	68	76.5	M6x10	M6	34	26.8	9.5	18.8	12.5
14	15.875	16	17	48	68	76.5	M6x10	M6	34	26.8	9.5	18.8	14.5
19	19.05			51	68	76.5	M6x10	M6	34	26.8	9.5	18.8	16.5

 i	M_{n2}	M_{a2}	M_{p2}	n_1	$n_{1\max}$	ϕ_S	ϕ_R	C_t	$R_{1\max}$	$R_{2\max}$	$A_{2\max}$	η	J_e [kgcm ²]	
	[Nm]	[Nm]	[Nm]	[min ⁻¹]	[min ⁻¹]	[arcmin]	[arcmin]	[Nm/arcmin]	[N]	[N]	[N]	%	8 ... 12.7	14 ... 19.05
TQFE 070 1_3	65	120	150	3500	4000	10'	5'	26	400	1400	2800	97	0.94	1.15
TQFE 070 1_4	60	110	160	3500	4000	10'	5'	26	400	1400	2800	97	0.57	0.78
TQFE 070 1_5	50	100	160	3200	4500	10'	5'	26	400	1400	2800	97	0.41	0.61
TQFE 070 1_7	50	100	160	4000	6000	10'	5'	26	400	1400	2800	97	0.27	0.48
TQFE 070 1_10	40	70	150	4000	6000	10'	5'	26	400	1400	2800	97	0.21	0.40
TQFE 070 2_9	65	120	150	3500	4000	12'	7'	23	400	1400	2800	94	0.67	0.81
TQFE 070 2_12	65	120	160	3500	4000	12'	7'	23	400	1400	2800	94	0.65	0.75
TQFE 070 2_15	65	120	160	3500	4000	12'	7'	23	400	1400	2800	94	0.65	0.75
TQFE 070 2_16	60	110	160	3500	4500	12'	7'	23	400	1400	2800	94	0.58	0.67
TQFE 070 2_20	60	110	160	3500	4500	12'	7'	23	400	1400	2800	94	0.47	0.60
TQFE 070 2_25	50	100	160	3200	4500	12'	7'	23	400	1400	2800	94	0.47	0.60
TQFE 070 2_28	50	100	160	4000	6000	12'	7'	23	400	1400	2800	94	0.41	0.55
TQFE 070 2_30	65	120	150	4000	6000	12'	7'	23	400	1400	2800	94	0.37	0.51
TQFE 070 2_35	50	100	160	4000	6000	12'	7'	23	400	1400	2800	94	0.41	0.55
TQFE 070 2_40	60	110	160	4000	6000	12'	7'	23	400	1400	2800	94	0.37	0.52
TQFE 070 2_50	50	100	160	4000	6000	12'	7'	23	400	1400	2800	94	0.36	0.49
TQFE 070 2_70	50	100	160	4000	6000	12'	7'	23	400	1400	2800	94	0.36	0.49
TQFE 070 2_100	40	70	150	4000	6000	12'	7'	23	400	1400	2800	94	0.36	0.48

Please contact us for different motor adapters and input shaft bore.

TQFE 090

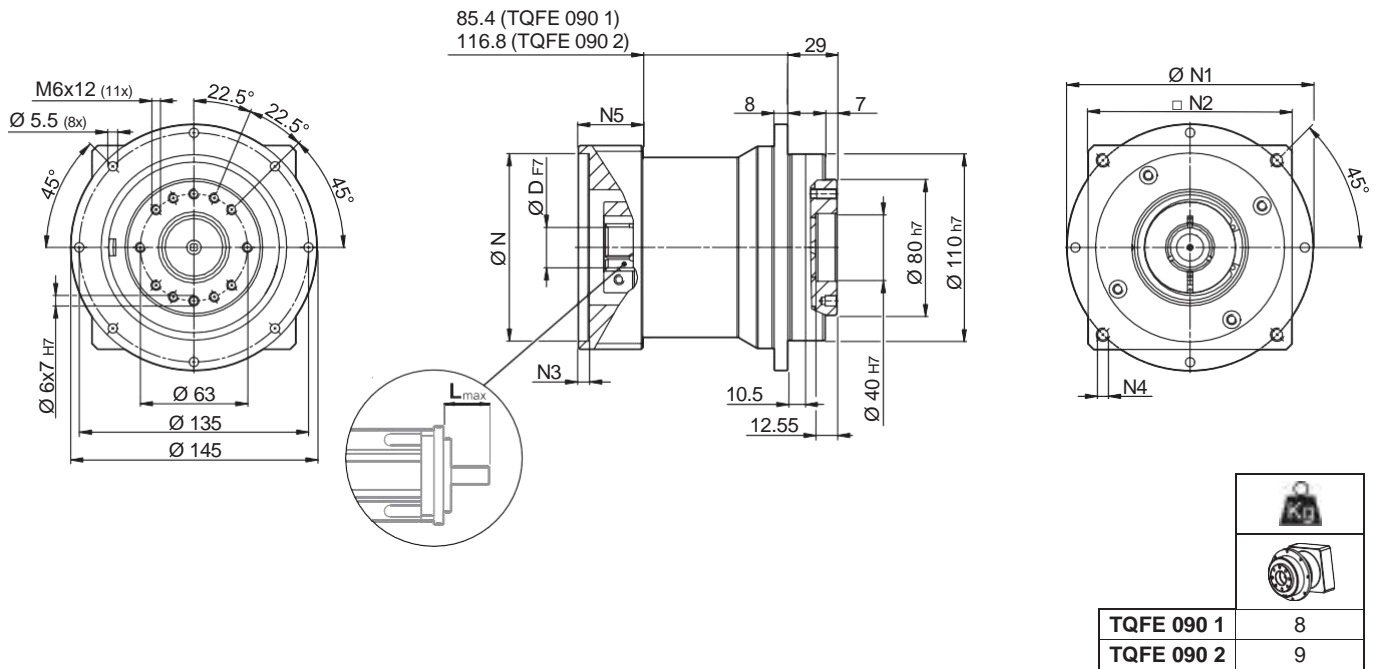

TQFE

												N	N1	N2	N3	N4	N5	L _{max}
50D	11	12	12.7	14	15	15.875	16	19	-	-	-	50	95	100	5	M6x14	28	40
55A	11	12	12.7	14	15	15.875	16	19	-	-	-	55	125.7	105	5	M6x16	28	40
60A2	11	12	12.7	14	15	15.875	16	19	-	-	-	60	75	100	6.5	M5x14	28	40
60AH2	11	12	12.7	14	15	15.875	16	19	-	-	-	60	75	100	4	6.5	33	40
60B1	11	12	12.7	14	15	15.875	16	19	-	-	-	60	85	100	6.5	M5x14	28	40
70A1	11	12	12.7	14	15	15.875	16	19	-	-	-	70	85	100	6.5	M6x14	28	40
70AH1	11	12	12.7	14	15	15.875	16	19	-	-	-	70	85	100	4	6.5	33	40
70B1	11	12	12.7	14	15	15.875	16	19	-	-	-	70	90	100	6.5	M5x12	28	40
80A1	11	12	12.7	14	15	15.875	16	19	-	-	-	80	100	100	6.5	M6x16	28	40
80AH1	11	12	12.7	14	15	15.875	16	19	-	-	-	80	100	100	4	6.5	33	40
95A	11	12	12.7	14	15	15.875	16	19	-	-	-	95	115	100	6.5	M8x18	28	40
95A1	11	12	12.7	14	15	15.875	16	19	22	24	-	95	115	100	6.5	M8x18	38	50
95B	11	12	12.7	14	15	15.875	16	19	-	-	-	95	130	115	6.5	M8x18	28	40
110A	11	12	12.7	14	15	15.875	16	19	-	-	-	110	130	115	6.5	M8x18	28	40
110A1	11	12	12.7	14	15	15.875	16	19	22	24	-	110	130	115	6.5	M8x20	38	50
110B	11	12	12.7	14	15	15.875	16	19	22	24	-	110	145	120	6.5	M8x20	38	50
110B1	11	12	12.7	14	15	15.875	16	19	22	24	28	110	145	120	6.5	M8x20	48	60
130A	11	12	12.7	14	15	15.875	16	19	22	24	-	130	165	140	6.5	M10x20	38	50
130A1	11	12	12.7	14	15	15.875	16	19	22	24	28	130	165	140	6.5	M10x25	48	60

TQFE 090

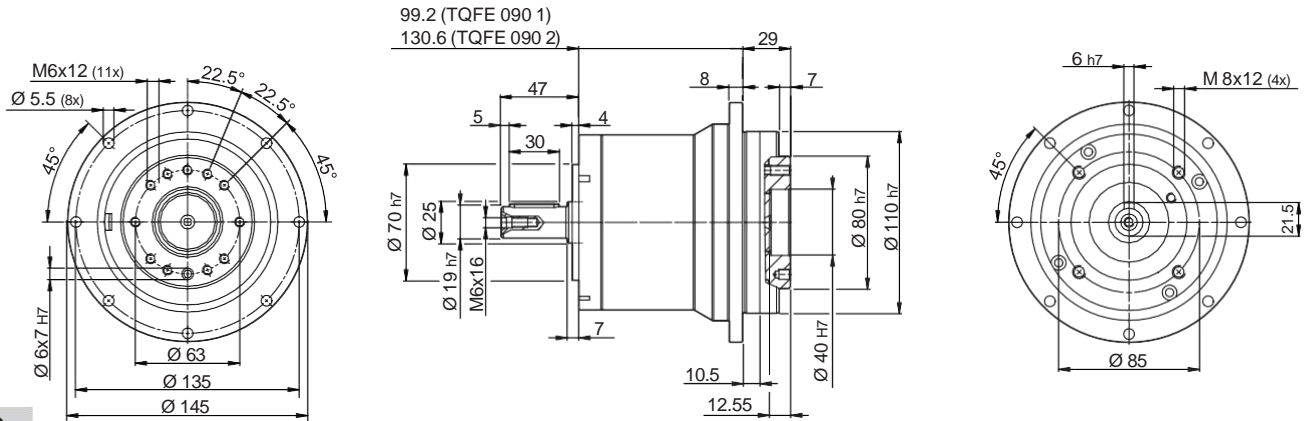

IS

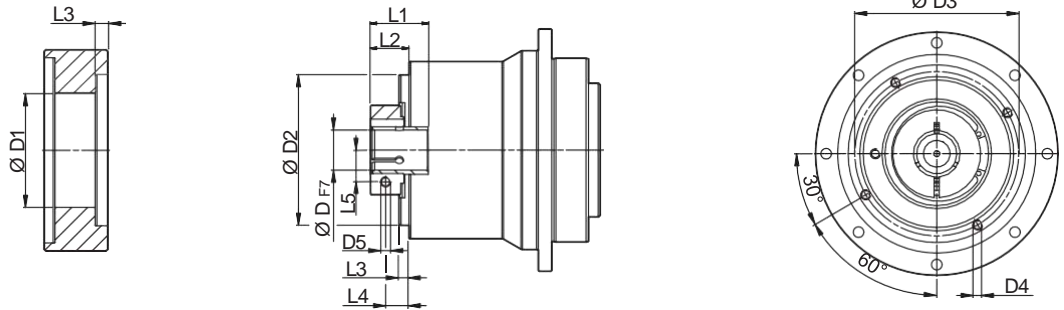

FM

TQFE

D				D1	D2	D3	D4	D5	L1	L2	L3	L4	L5
11	12	12.7		43	90	98	M6x15	M6	33.5	20	7.6	12	12.5
14	15	15.875	16	48	90	98	M6x15	M6	33.5	20	7.6	12.5	14.5
19				51	90	98	M6x15	M6	33.5	20	7.6	12.5	16.5
22	24			56.5	90	98	M6x15	M6	36.5	23	7.6	14	19
28				70	90	98	M6x15	M8	36.5	23	7.6	14	22.5
32				71	90	98	M6x15	M8	38	24.5	7.6	15.5	24.5

	i	M _{n2}	M _{a2}	M _{p2}	n ₁	n _{1 max}	φ _S	φ _R	C _t	R _{1 max}	R _{2 max}	A _{2 max}	η	J _G [kgcm ²]			
		[Nm]	[Nm]	[Nm]	[min ⁻¹]	[min ⁻¹]	[arcmin]	[Nm/arcmin]	[N]	[N]	[N]	%	11 ... 12.7	14 ... 19	22 ; 24	28 ; 32	
TQFE 090 1_3		155	280	300	3000	4000	10'	5'	60	600	2500	4000	97	2.79	2.87	3.48	4.1
TQFE 090 1_4		155	300	360	3000	4500	10'	5'	60	600	2500	4000	97	1.53	1.60	2.21	2.84
TQFE 090 1_5		125	240	360	3000	4500	10'	5'	60	600	2500	4000	97	0.96	1.03	1.64	2.27
TQFE 090 1_7		125	240	360	3500	4500	10'	5'	60	600	2500	4000	97	0.55	0.62	1.22	1.86
TQFE 090 1_10		100	160	300	3500	5000	10'	5'	60	600	2500	4000	97	0.51	0.59	1.00	1.63
TQFE 090 2_9		155	280	300	3000	4000	12'	7'	50	600	2500	4000	94	1.77	1.82	2.86	3.05
TQFE 090 2_12		155	300	360	3000	4000	12'	7'	50	600	2500	4000	94	1.64	1.71	2.35	2.87
TQFE 090 2_15		155	300	360	3000	4000	12'	7'	50	600	2500	4000	94	1.58	1.66	2.01	2.83
TQFE 090 2_16		155	300	360	3000	4500	12'	7'	50	600	2500	4000	94	0.94	1.01	1.78	2.32
TQFE 090 2_20		155	300	360	3000	4500	12'	7'	50	600	2500	4000	94	0.92	1.00	1.78	2.29
TQFE 090 2_25		125	240	360	3000	4500	12'	7'	50	600	2500	4000	94	0.81	0.89	1.47	2.00
TQFE 090 2_28		125	240	360	3500	5000	12'	7'	50	600	2500	4000	94	0.59	0.67	1.31	1.94
TQFE 090 2_30		155	300	300	3500	5000	12'	7'	50	600	2500	4000	94	0.47	0.55	1.27	1.82
TQFE 090 2_35		125	240	360	3500	5000	12'	7'	50	600	2500	4000	94	0.50	0.58	1.32	1.91
TQFE 090 2_40		155	300	360	3500	5000	12'	7'	50	600	2500	4000	94	0.47	0.55	1.27	1.82
TQFE 090 2_50		125	240	360	3500	5000	12'	7'	50	600	2500	4000	94	0.47	0.55	1.25	1.80
TQFE 090 2_70		125	240	360	3500	5000	12'	7'	50	600	2500	4000	94	0.47	0.53	1.25	1.79
TQFE 090 2_100		100	160	300	3500	5000	12'	7'	50	600	2500	4000	94	0.47	0.53	1.25	1.79

Please contact us for different motor adapters and input shaft bore.



TQFEK Series

The TQFEK series offers optimized performance and features at an optimum value-price ratio.

An exceptionally compact and standardized flange interface combined with optimal positioning accuracy make it suitable for a wide range of industrial applications.

Its right-angle design allows more compactness for space-saving layouts.

Main benefits

- High torsional stiffness
- High compactness
- Easy and quick installation
- Standardized flange for great compatibility
- Compact design for space-saving layouts

Main features

- Nominal output torque (Nm)



- Torsional backlash (arcmin)



- Torsional stiffness (Nm/arcmin)



- Max tilting moment (Nm)



Protection class

- IP54

Frame sizes

- 060
- 070
- 090

Main options

- Input versions

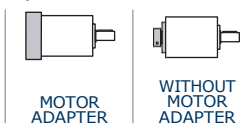

- Lubrication



8 FEATURES OF TQFEK SERIES

The TQFEK Series right-angle design represents the answer for applications requiring compact, space-saving solutions.

Its standardized flange ensures great compatibility while its proportioned design allows quiet running and provides a long service life without maintenance requirements.

Motor mounting is an operation that can be easily conducted without the need of any particular tooling, other than that usually available in a normally equipped workshop.

- Available with either standard (STD) or reduced (LOW) backlash:
2-stage units: standard $\phi_S \leq 12'$; reduced $\phi_R \leq 7'$
3-stage units: standard $\phi_S \leq 14'$; reduced $\phi_R \leq 9'$
- Its degree of protection IP54 provides protection against dust and liquid splashes.
- Input section oil seals made from a Fluoroelastomer compound are supplied as standard.
- Noise pressure level $LP \leq 70$ dB(A). Conditions: distance 1 m; measured without load an input speed of $n_1 = 3000$ min⁻¹; $i=10$.
- Units are factory packed with synthetic grease to NLGI consistency class 00, in the absence of contamination the lubricant requires no periodical changes.
- Ambient temperature min -20°C, max +30°C. For temperature higher than 30°C please consider derating factor f_T .
- Housing temperature must not exceed $T_{max} = 90^\circ\text{C}$.

		Distribution of nominal torque M_{n2} [Nm]																	
	[i]	3	4	5	7	9	10	12	15	16	20	25	8	30	35	40	50	70	100
TQFEK 060		29	30	25	25	29	18	29	29	30	30	30	30	29	30	30	30	30	18
TQFEK 070		40	50	50	50	65	40	65	65	60	60	50	50	65	50	60	50	50	40
TQFEK 090		80	105	130	125	155	100	155	155	155	155	125	125	155	125	155	125	125	100

TQFEK

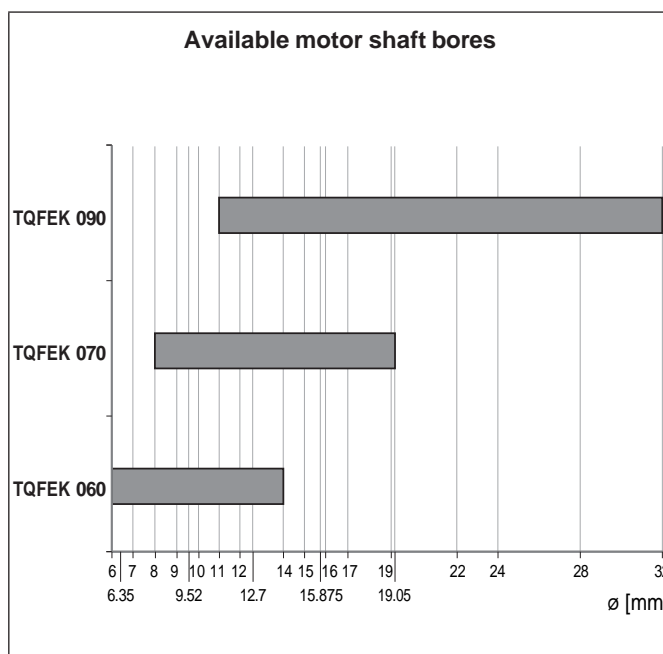
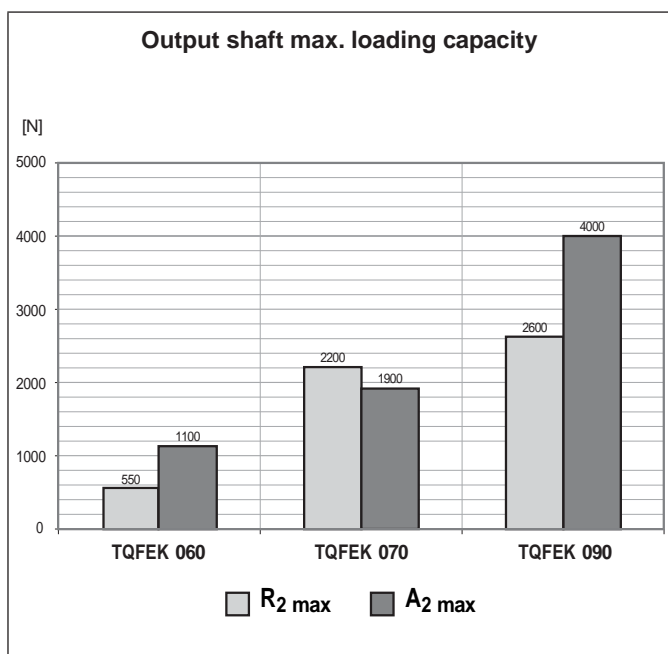

8.1 ORDERING CODE

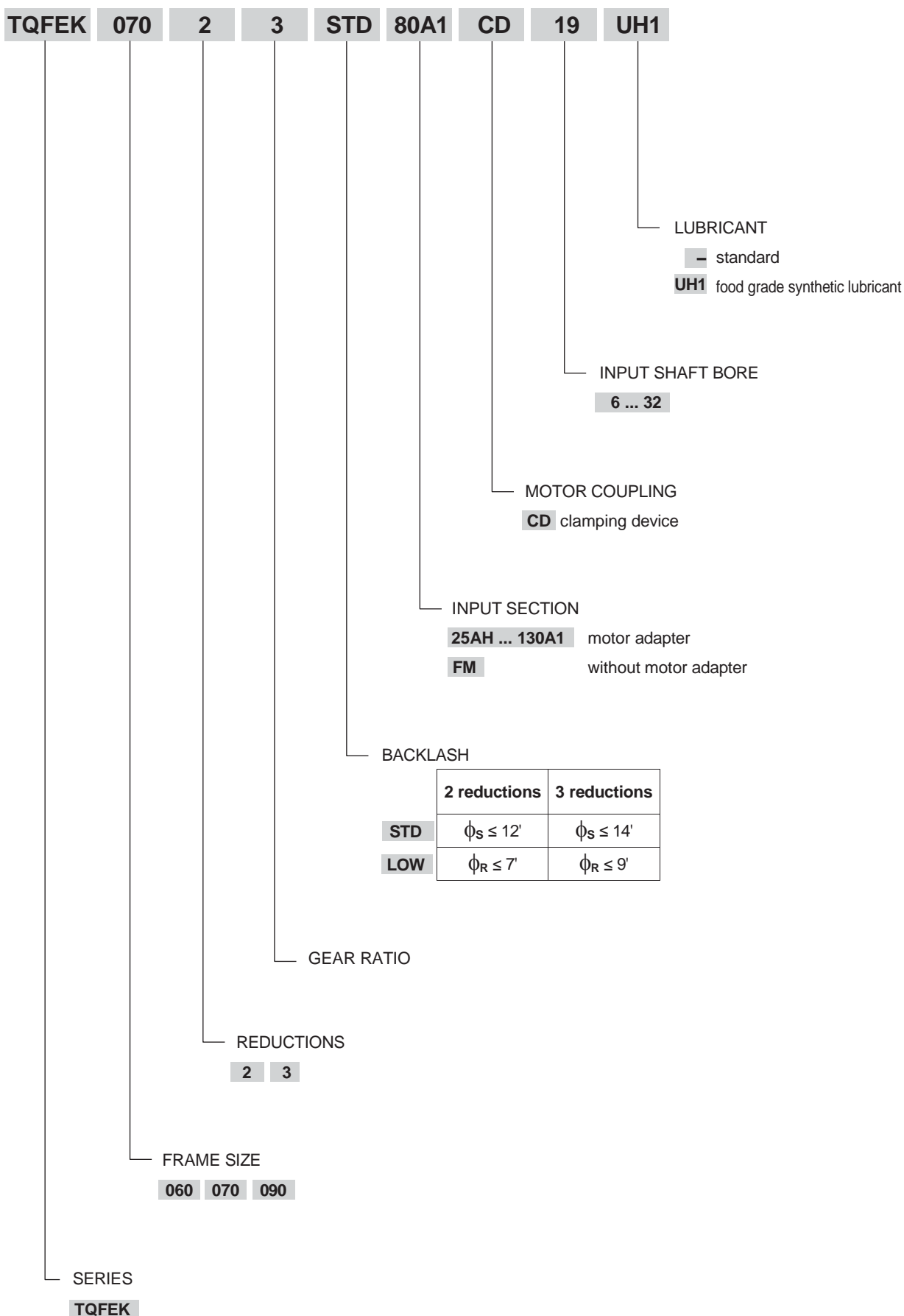

TQFEK

8.2 DIMENSIONS AND TECHNICAL SPECIFICATIONS

TQFEK 060

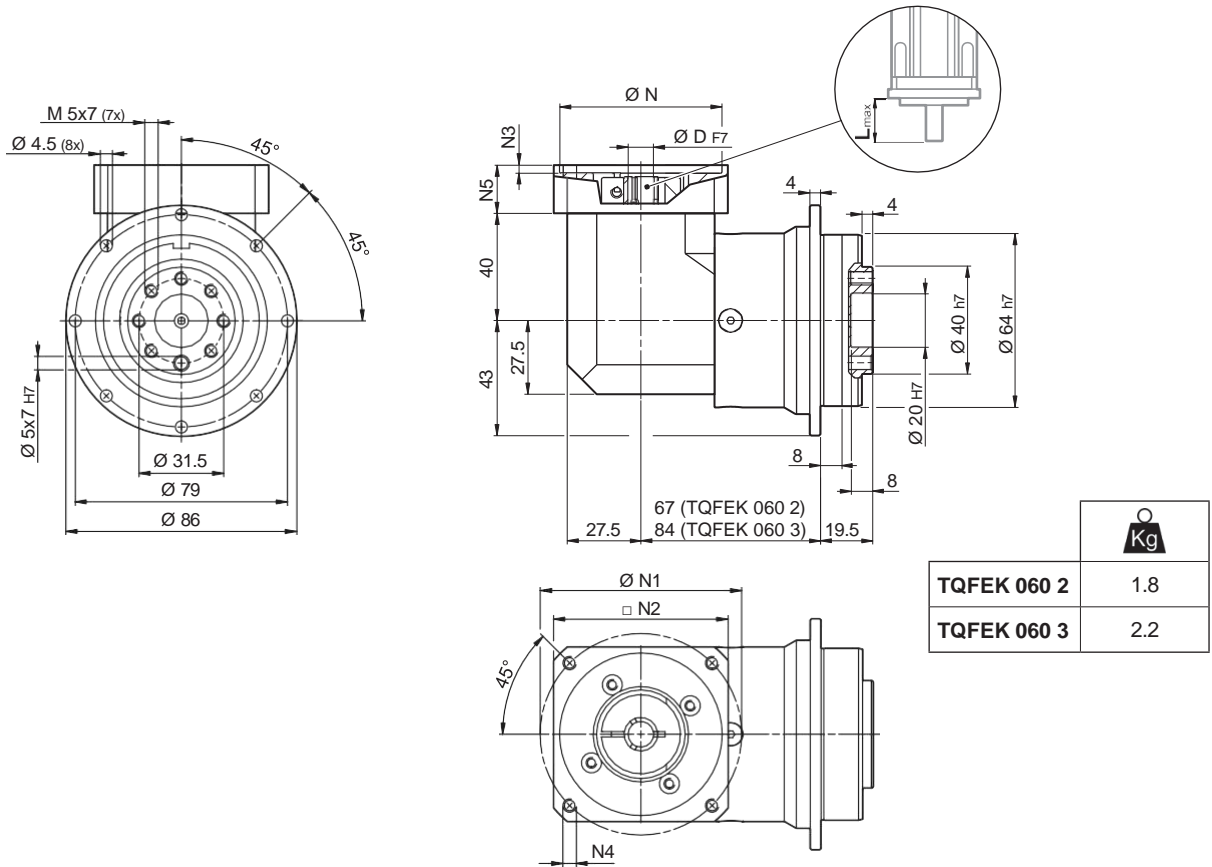

TQFEK

												N	N1		N2	N3	N4	N5	L _{max}
	6	6.35	7	8	9	9.52	-	-	-	-	-		min	max					
25AH	6	6.35	7	8	9	9.52	-	-	-	-	-	25	39	56					
26AH	6	6.35	7	8	9	9.52	-	-	-	-	-	26	39	56					
28AH	6	6.35	7	8	9	9.52	-	-	-	-	-	28	39	56					
30AH	6	6.35	7	8	9	9.52	-	-	-	-	-	30	39	56					
32AH	6	6.35	7	8	9	9.52	-	-	-	-	-	32	39	56	65	3.5	4.5	25	25
34AH	6	6.35	7	8	9	9.52	-	-	-	-	-	34	40	56					
36AH	6	6.35	7	8	9	9.52	-	-	-	-	-	36	42	56					
39AH	6	6.35	7	8	9	9.52	-	-	-	-	-	39	45	56					
40AH	6	6.35	7	8	9	9.52	-	-	-	-	-	40	46	56					
38B	6	6.35	7	8	9	9.52	10	11	12	12.7	-	38.1	66.6	60	3	M4x10	18	25	
40B	6	6.35	7	8	9	9.52	10	11	12	12.7	-	40	63	60	3	M4x10	18	25	
50A	6	6.35	7	8	9	9.52	10	11	12	12.7	-	50	60	60	3	M4x10	18	25	
50B	6	6.35	7	8	9	9.52	10	11	12	12.7	14	50	65	60	3	M5x12	23	30	
50BH	6	6.35	7	8	9	9.52	10	11	12	12.7	14	50	65	65	3	5.5	25	32	
50C	6	6.35	7	8	9	9.52	10	11	12	12.7	14	50	70	60	3	M4x10	23	30	
55MH	6	6.35	7	8	9	9.52	10	11	12	12.7	-	55	80	65	2	5.5	16	23	
60A	6	6.35	7	8	9	9.52	10	11	12	12.7	-	60	75	65	3	M5x12	18	25	
60A1	6	6.35	7	8	9	9.52	10	11	12	12.7	14	60	75	65	3	M5x12	23	30	
60B	6	6.35	7	8	9	9.52	10	11	12	12.7	14	60	85	75	3	M5x12	23	30	
60C	6	6.35	7	8	9	9.52	10	11	12	12.7	14	60	90	75	3	M5x12	23	30	
70A	6	6.35	7	8	9	9.52	10	11	12	12.7	14	70	85	75	3	M6x15	23	30	
70B	6	6.35	7	8	9	9.52	10	11	12	12.7	14	70	90	75	3	M5x12	23	30	
73A	6	6.35	7	8	9	9.52	10	11	12	12.7	14	73	98.4	85	3	M5x12	25	32	
80A	6	6.35	7	8	9	9.52	10	11	12	12.7	14	80	100	85	3	M6x15	23	30	

Please contact us for different motor adapters and input shaft bore.

TQFEK 060

FM

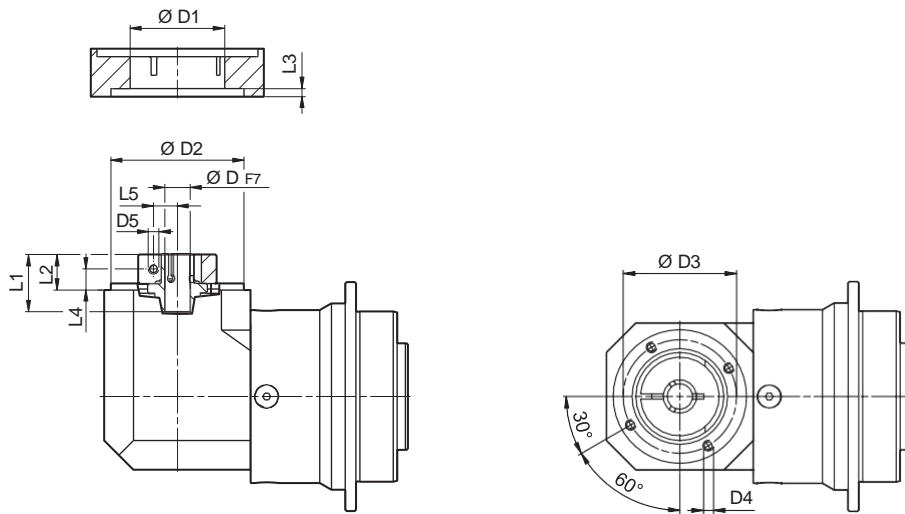

				D1	D2	D3	D4	D5	L1	L2	L3	L4	L5
6	6.35	7		32.5	50	42.5	M4x8	M4	21.7	13.2	3	8.2	8
8	9	9.52	10	32.5	50	42.5	M4x8	M4	21.7	13.2	3	8.2	9
11	12	12.7		35.5	50	42.5	M4x8	M4	22	13.5	3	8.5	11
14				35.5	50	42.5	M4x8	M4	25	17	3	10.2	11.5

TQFEK

	M_{n2}	M_{a2}	M_{p2}	n_1	n_{1max}	ϕ_S	ϕ_R	C_t	R_{1max}	R_{2max}	A_{2max}	η	J_G [kgcm ²]	
	[Nm]	[Nm]	[Nm]	[min ⁻¹]	[min ⁻¹]	[arcmin]	[arcmin]	$\frac{Nm}{arcmin}$	[N]	[N]	[N]	%	6 ... 10	11 ... 14
TQFEK 060 2_3	29	45	60	3300	4000	12'	7'	6	200	550	1100	94	0.31	0.35
TQFEK 060 2_4	30	45	70	3500	5000	12'	7'	6	200	550	1100	94	0.30	0.32
TQFEK 060 2_5	25	40	70	3500	5000	12'	7'	6	200	550	1100	94	0.28	0.30
TQFEK 060 2_7	25	40	70	4000	5000	12'	7'	6	200	550	1100	94	0.26	0.27
TQFEK 060 2_10	18	30	60	4000	6000	12'	7'	6	200	550	1100	94	0.26	0.25
TQFEK 060 3_9	29	55	60	3300	4000	14'	9'	6	200	550	1100	91	0.28	0.31
TQFEK 060 3_12	29	55	70	3300	4000	14'	9'	6	200	550	1100	91	0.28	0.31
TQFEK 060 3_15	29	55	70	3300	4000	14'	9'	6	200	550	1100	91	0.27	0.30
TQFEK 060 3_16	30	45	70	3500	5000	14'	9'	6	200	550	1100	91	0.25	0.27
TQFEK 060 3_20	30	45	70	3500	5000	14'	9'	6	200	550	1100	91	0.25	0.27
TQFEK 060 3_25	30	45	70	3500	5000	14'	9'	6	200	550	1100	91	0.25	0.27
TQFEK 060 3_28	30	45	70	4000	6000	14'	9'	6	200	550	1100	91	0.24	0.26
TQFEK 060 3_30	29	55	60	4000	6000	14'	9'	6	200	550	1100	91	0.23	0.25
TQFEK 060 3_35	30	45	70	4000	6000	14'	9'	6	200	550	1100	91	0.23	0.25
TQFEK 060 3_40	30	45	70	4000	6000	14'	9'	6	200	550	1100	91	0.23	0.25
TQFEK 060 3_50	30	45	70	4000	6000	14'	9'	6	200	550	1100	91	0.20	0.22
TQFEK 060 3_70	30	45	70	4000	6000	14'	9'	6	200	550	1100	91	0.20	0.22
TQFEK 060 3_100	18	30	60	4000	6000	14'	9'	6	200	550	1100	91	0.20	0.22

TQFEK 070

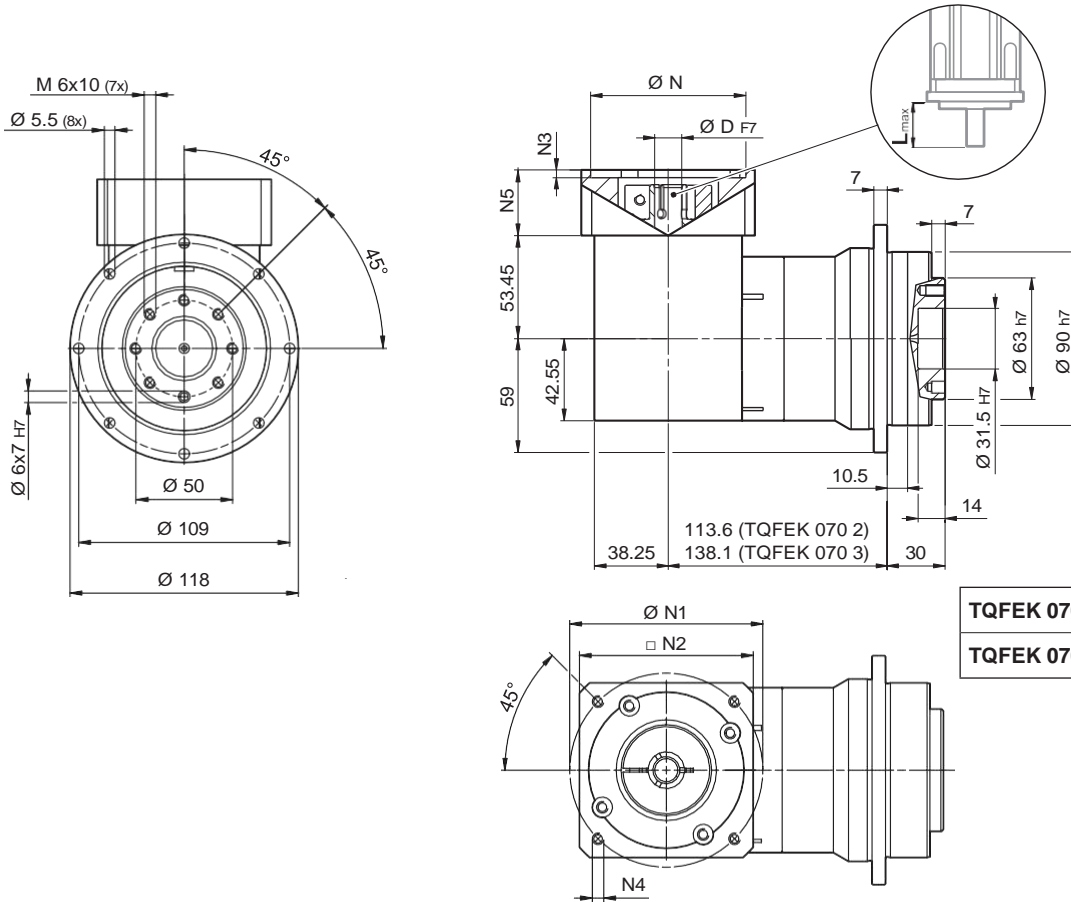

TQFEK 070 2	4.2
TQFEK 070 3	5.1

TQFEK

	D	D											N	N1	N2	N3	N4	N5	L _{max}	
		8	9	9.52	11	12	12.7	14	-	-	-	-								-
40B1		8	9	9.52	11	12	12.7	14	-	-	-	-	-	40	63	80	4	M4x12	34	40
45A		8	9	9.52	11	12	12.7	-	-	-	-	-	-	45	63	80	4	M4x12	34	40
50B1		8	9	9.52	11	12	12.7	14	-	-	-	-	-	50	65	80	4	M5x16	34	40
50BH1		8	9	9.52	11	12	12.7	14	-	-	-	-	-	50	65	80	4	5.5	34	40
50C1		8	9	9.52	11	12	12.7	14	-	-	-	-	-	50	70	80	4	M4x10	34	40
50D		8	9	9.52	11	12	12.7	14	-	-	-	-	-	50	95	80	4	M6x20	34	40
55A		8	9	9.52	11	12	12.7	14	15.875	16	17	19	19.05	55.5	125.7	105	4	M6x20	34	40
60A2		8	9	9.52	11	12	12.7	14	-	-	-	-	-	60	75	80	4	M5x16	34	40
60AH2		8	9	9.52	11	12	12.7	14	-	-	-	-	-	60	75	90	4	6.5	34	40
60B1		8	9	9.52	11	12	12.7	14	15.875	16	-	-	-	60	85	80	4	M5x16	34	40
60C1		8	9	9.52	11	12	12.7	14	15.875	16	-	-	-	60	90	80	4	M5x16	34	40
70A1		8	9	9.52	11	12	12.7	14	15.875	16	17	19	19.05	70	85	80	4	M6x20	34	40
70AH1		8	9	9.52	11	12	12.7	14	15.875	16	17	19	19.05	70	85	90	4	6.5	34	40
70B1		8	9	9.52	11	12	12.7	14	15.875	16	17	19	19.05	70	90	80	4	M5x16	34	40
73A1		8	9	9.52	11	12	12.7	14	-	-	-	-	-	73	98.4	85	4	M5x16	34	40
80A1		8	9	9.52	11	12	12.7	14	15.875	16	17	19	19.05	80	100	90	4	M6x16	34	40
95A		8	9	9.52	11	12	12.7	14	15.875	16	17	19	19.05	95	115	100	4	M8x20	34	40
95B		8	9	9.52	11	12	12.7	14	15.875	16	17	19	19.05	95	130	115	4	M8x20	34	40
110A		8	9	9.52	11	12	12.7	14	15.875	16	17	19	19.05	110	130	115	4	M8x20	34	40
110B		8	9	9.52	11	12	12.7	14	15.875	16	17	19	19.05	110	145	120	6.5	M8x20	44	50
110B1		8	9	9.52	11	12	12.7	14	15.875	16	17	19	19.05	110	145	120	6.5	M8x20	54	60

Please contact us for different motor adapters and input shaft bore.

TQFEK 070

FM

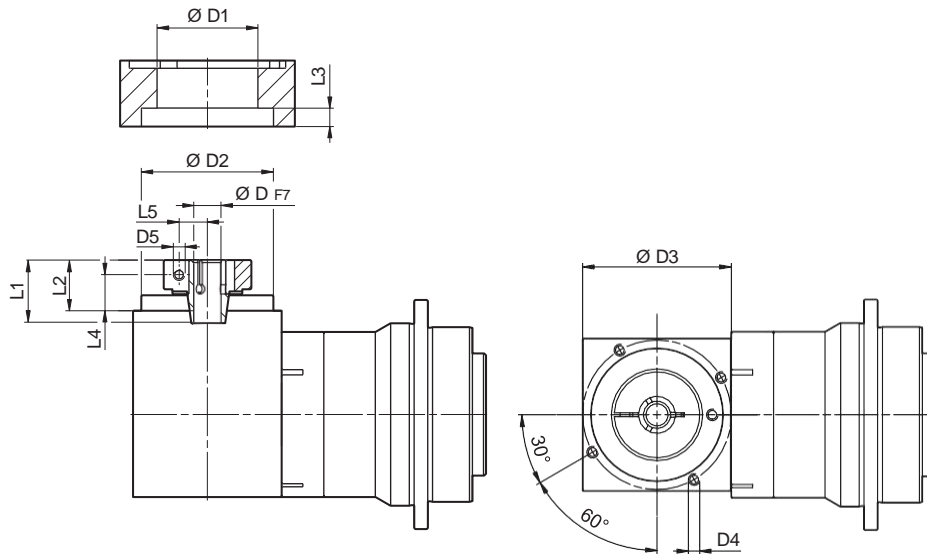

D				D1	D2	D3	D4	D5	L1	L2	L3	L4	L5
8	9	9.52		38	68	76.5	M6x10	M6	34	26.8	9.5	18.8	10.5
11	12	12.7		52	68	76.5	M6x10	M6	34	26.8	9.5	18.8	12.5
14	15.875	16	17	48	68	76.5	M6x10	M6	34	26.8	9.5	18.8	14.5
19	19.05			51	68	76.5	M6x10	M6	34	26.8	9.5	18.8	16.5

 i	M _{n2}	M _{a2}	M _{p2}	n ₁	n _{1 max}	φ _S	φ _R	C _t	R _{1 max}	R _{2 max}	A _{2 max}	η	J _G [kgcm ²]	
	[Nm]	[Nm]	[Nm]	[min ⁻¹]	[min ⁻¹]	[arcmin]		$\frac{Nm}{arcmin}$	[N]	[N]	[N]	%	8 ... 12.7	14 ... 19.05
TQFEK 070 2_3	40	60	150	2900	3500	12'	7'	26	400	2200	1900	94	1.11	1.35
TQFEK 070 2_4	50	80	160	3100	4500	12'	7'	26	400	2200	1900	94	0.85	1.10
TQFEK 070 2_5	50	80	160	3200	4500	12'	7'	26	400	2200	1900	94	0.74	0.95
TQFEK 070 2_7	50	80	160	4000	6000	12'	7'	26	400	2200	1900	94	0.64	0.89
TQFEK 070 2_10	40	70	150	4000	6000	12'	7'	26	400	2200	1900	94	0.61	0.83
TQFEK 070 3_9	65	120	150	2900	3500	14'	9'	23	400	2200	1900	91	0.94	1.01
TQFEK 070 3_12	65	120	160	3100	3500	14'	9'	23	400	2200	1900	91	0.93	1.06
TQFEK 070 3_15	65	120	160	3200	3500	14'	9'	23	400	2200	1900	91	0.93	1.06
TQFEK 070 3_16	60	110	160	3100	4500	14'	9'	23	400	2200	1900	91	0.86	0.98
TQFEK 070 3_20	60	110	160	3200	4500	14'	9'	23	400	2200	1900	91	0.80	0.97
TQFEK 070 3_25	50	100	160	3200	4500	14'	9'	23	400	2200	1900	91	0.80	0.97
TQFEK 070 3_28	50	100	160	4000	6000	14'	9'	23	400	2200	1900	91	0.77	0.95
TQFEK 070 3_30	65	120	150	4000	6000	14'	9'	23	400	2200	1900	91	0.74	0.91
TQFEK 070 3_35	50	100	160	4000	6000	14'	9'	23	400	2200	1900	91	0.76	0.95
TQFEK 070 3_40	60	110	160	4000	6000	14'	9'	23	400	2200	1900	91	0.68	0.95
TQFEK 070 3_50	50	100	160	4000	6000	14'	9'	23	400	2200	1900	91	0.66	0.92
TQFEK 070 3_70	50	100	160	4000	6000	14'	9'	23	400	2200	1900	91	0.66	0.92
TQFEK 070 3_100	40	70	150	4000	6000	14'	9'	23	400	2200	1900	91	0.66	0.92

TQFEK

TQFEK 090

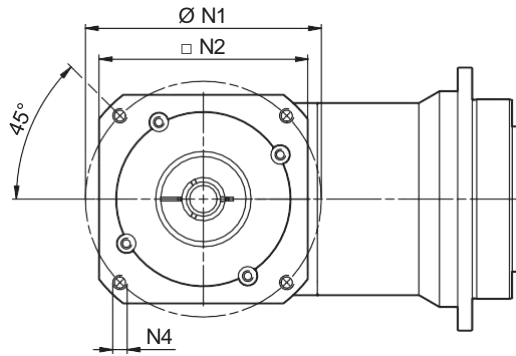
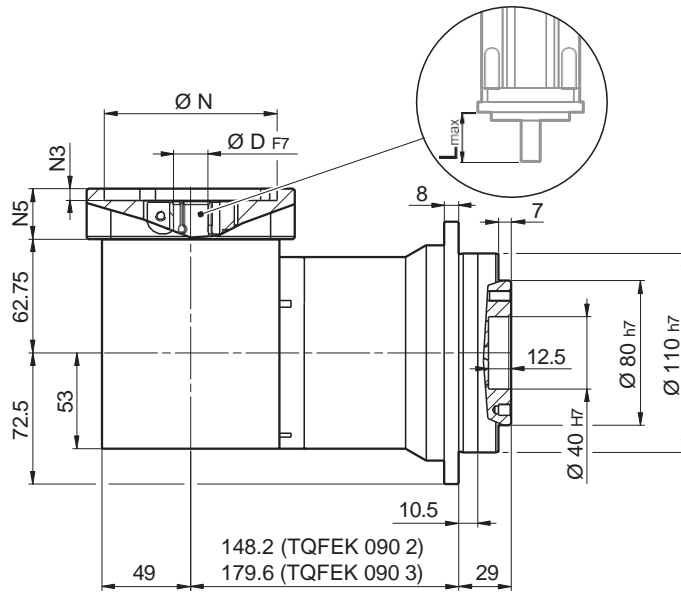
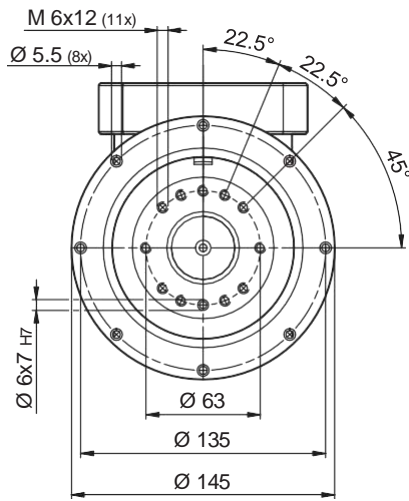

	Kg
TQFEK 090 2	8.5
TQFEK 090 3	9.5

TQFEK

		N	N1	N2	N3	N4	N5	L _{max}
50D	11 12 12.7 14 15 15.875 16 19 - - - -	50	95	100	5	M6x14	28	40
55A	11 12 12.7 14 15 15.875 16 19 - - - -	55	125.7	105	5	M6x16	28	40
60A2	11 12 12.7 14 15 15.875 16 19 - - - -	60	75	100	6.5	M5x14	28	40
60AH2	11 12 12.7 14 15 15.875 16 19 - - - -	60	75	100	4	6.5	33	40
60B1	11 12 12.7 14 15 15.875 16 19 - - - -	60	85	100	6.5	M5x14	28	40
70A1	11 12 12.7 14 15 15.875 16 19 - - - -	70	85	100	6.5	M6x14	28	40
70AH1	11 12 12.7 14 15 15.875 16 19 - - - -	70	85	100	4	6.5	33	40
70B1	11 12 12.7 14 15 15.875 16 19 - - - -	70	90	100	6.5	M5x12	28	40
80A1	11 12 12.7 14 15 15.875 16 19 - - - -	80	100	100	6.5	M6x16	28	40
80AH1	11 12 12.7 14 15 15.875 16 19 - - - -	80	100	100	4	6.5	33	40
95A	11 12 12.7 14 15 15.875 16 19 - - - -	95	115	100	6.5	M8x18	28	40
95A1	11 12 12.7 14 15 15.875 16 19 22 24 - -	95	115	100	6.5	M8x18	38	50
95B	11 12 12.7 14 15 15.875 16 19 - - - -	95	130	115	6.5	M8x18	28	40
110A	11 12 12.7 14 15 15.875 16 19 - - - -	110	130	115	6.5	M8x18	28	40
110A1	11 12 12.7 14 15 15.875 16 19 22 24 - -	110	130	115	6.5	M8x20	38	50
110B	11 12 12.7 14 15 15.875 16 19 22 24 - -	110	145	120	6.5	M8x20	38	50
110B1	11 12 12.7 14 15 15.875 16 19 22 24 28 -	110	145	120	6.5	M8x20	48	60
130A	11 12 12.7 14 15 15.875 16 19 22 24 - -	130	165	140	6.5	M10x20	38	50
130A1	11 12 12.7 14 15 15.875 16 19 22 24 28 32	130	165	140	6.5	M10x25	48	60

Please contact us for different motor adapters and input shaft bore.

TQFEK 090

FM

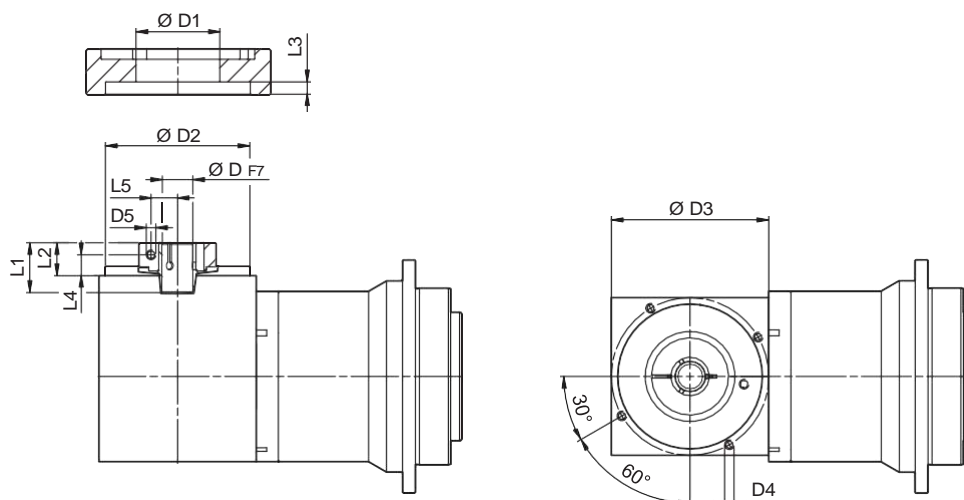

D				D1	D2	D3	D4	D5	L1	L2	L3	L4	L5
11	12	12.7		43	90	98	M6x15	M6	33.5	20	7.6	12	12.5
14	15	15.875	16	48	90	98	M6x15	M6	33.5	20	7.6	12.5	14.5
19				51	90	98	M6x15	M6	33.5	20	7.6	12.5	16.5
22	24			56.5	90	98	M6x15	M6	36.5	23	7.6	14	19
28				70	90	98	M6x15	M8	36.5	23	7.6	14	22.5
32				71	90	98	M6x15	M8	38	24.5	7.6	15.5	24.5

	i	M _{n2} [Nm]	M _{a2} [Nm]	M _{p2} [Nm]	n ₁ [min ⁻¹]	n _{1 max} [min ⁻¹]	φ _S [arcmin]	φ _R [arcmin]	C _t [Nm/arcmin]	R _{1 max} [N]	R _{2 max} [N]	A _{2 max} [N]	η %	J _G [kgcm ²]			
														D			
														11 ... 12.7	14 ... 19	22 ; 24	28 ; 32
TQFEK 090 2_3		80	120	300	3000	4000	12'	7'	60	600	2600	4000	94	2.94	3.00	3.59	4.58
TQFEK 090 2_4		105	160	360	3000	4500	12'	7'	60	600	2600	4000	94	1.76	1.83	2.32	3.32
TQFEK 090 2_5		130	195	360	3000	4500	12'	7'	60	600	2600	4000	94	1.38	1.45	1.75	2.75
TQFEK 090 2_7		125	240	360	3500	4500	12'	7'	60	600	2600	4000	94	1.06	1.21	1.60	2.51
TQFEK 090 2_10		100	160	300	3500	5000	12'	7'	60	600	2600	4000	94	1.11	1.27	1.38	2.37
TQFEK 090 3_9		155	180	300	3000	4000	14'	9'	50	600	2600	4000	91	1.95	2.05	2.97	3.53
TQFEK 090 3_12		155	300	360	3000	4000	14'	9'	50	600	2600	4000	91	1.72	1.87	2.46	3.35
TQFEK 090 3_15		155	300	360	3000	4000	14'	9'	50	600	2600	4000	91	1.68	1.84	2.12	2.83
TQFEK 090 3_16		155	300	360	3000	4500	14'	9'	50	600	2600	4000	91	1.09	1.24	1.89	2.80
TQFEK 090 3_20		155	300	360	3000	4500	14'	9'	50	600	2600	4000	91	1.26	1.42	1.99	2.77
TQFEK 090 3_25		125	240	360	3000	4500	14'	9'	50	600	2600	4000	91	1.31	1.47	1.74	2.64
TQFEK 090 3_28		125	240	360	3500	5000	14'	9'	50	600	2600	4000	91	1.09	1.26	1.58	1.94
TQFEK 090 3_30		155	300	300	3500	5000	14'	9'	50	600	2600	4000	91	1.08	1.23	1.65	2.56
TQFEK 090 3_35		125	240	360	3500	5000	14'	9'	50	600	2600	4000	91	1.09	1.25	1.68	2.64
TQFEK 090 3_40		155	300	360	3500	5000	14'	9'	50	600	2600	4000	91	1.12	1.27	1.69	2.60
TQFEK 090 3_50		125	240	360	3500	5000	14'	9'	50	600	2600	4000	91	1.12	1.27	1.69	2.60
TQFEK 090 3_70		125	240	360	3500	5000	14'	9'	50	600	2600	4000	91	1.08	1.21	1.63	2.53
TQFEK 090 3_100		100	160	300	3500	5000	14'	9'	50	600	2600	4000	91	1.08	1.21	1.63	2.53

TQFEK



SL Series

The SL series features a compact design optimized for timing belt pulley drive systems.

This series represents the most suitable solution for belt servo-drives conveyors and all other applications requiring positioning accuracy, an ultra-compact size and high radial load capacity.

The output design compatible with market standards allows easy retrofits and a high level of freedom in projects development.

Main benefits

- Optimized for timing belt pulley drive systems
- Great position accuracy
- High compatibility for easy retrofits

Main features

- Nominal output torque (Nm)

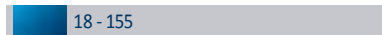

- Torsional backlash (arcmin)



- Torsional stiffness (Nm/arcmin)



- Max tilting moment (Nm)

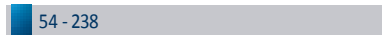

Protection class

- IP54

Frame sizes

- 070
- 090
- 120

Main options

- Input versions

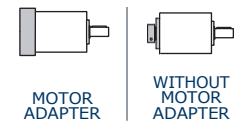

- Output shafts versions

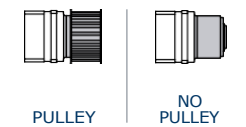

- Lubrication



- High power version (P option)



9 FEATURES OF SL SERIES

The SL Series from Tecnoingranaggi knows no rivals in compactness, efficiency and optimisation for timing belt pulley drive systems. Reduced backlash units from the SL Series are the ideal complement to conveyor belt servo-drives and all other applications needing to combine high precision with ultra-compact size.

- Available with either standard (STD) or reduced (LOW) backlash:
1-stage units: standard $\phi_S \leq 12'$; reduced $\phi_R \leq 6'$
2-stage units: standard $\phi_S \leq 15'$; reduced $\phi_R \leq 8'$
- Its degree of protection IP54 provides protection against dust and liquid splashes.
- Input section oil seals made from a Fluoroelastomer compound are supplied as standard.
- Noise pressure level $L_p \leq 70$ dB(A). Conditions: distance 1 m; measured without load an input speed of $n_1 = 3000$ min⁻¹; $i=10$.
- Units are factory packed with synthetic grease to NLGI consistency class 00, in the absence of contamination the lubricant requires no periodical changes.
- Ambient temperature min -20°C, max +30°C. For temperature higher than 30°C please consider derating factor f_T .
- Housing temperature must not exceed $T_{max} = 90^\circ\text{C}$.
- Available as Version P with higher output torque.

		Distribution of nominal torque M_{n2} [Nm]																	
	[i]	3	4	5	7	9	10	12	15	16	20	25	28	30	35	40	50	70	100
SL 070		18	25	25	25	18	18	25	25	25	25	25	25	18	25	25	25	25	18
SL 070P		29	30	28	28	29	20	29	29	30	30	30	30	29	30	30	30	30	20
SL 090		37	43	43	43	37	37	43	43	43	43	43	43	37	43	43	43	43	37
SL 090P		65	60	50	50	65	40	65	65	60	60	50	50	65	50	60	50	50	40
SL 120		95	110	110	110	95	95	110	110	110	110	110	110	95	110	110	110	110	95
SL 120P		155	155	125	125	155	100	155	155	155	155	125	125	155	125	155	125	125	100

TS

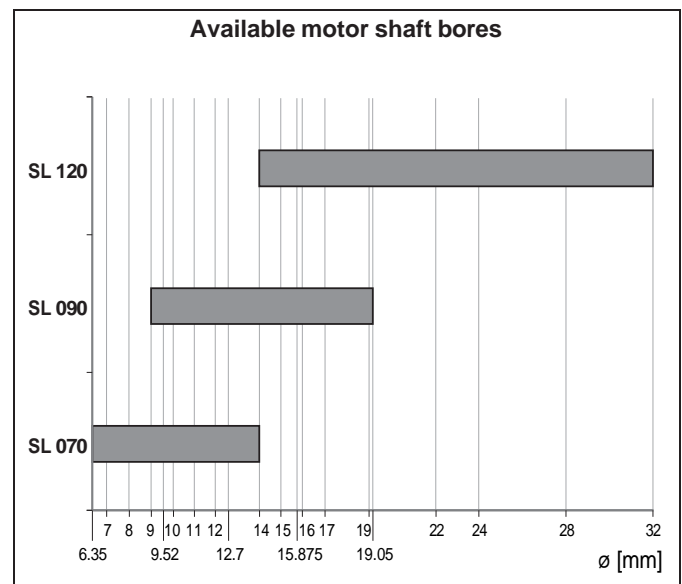
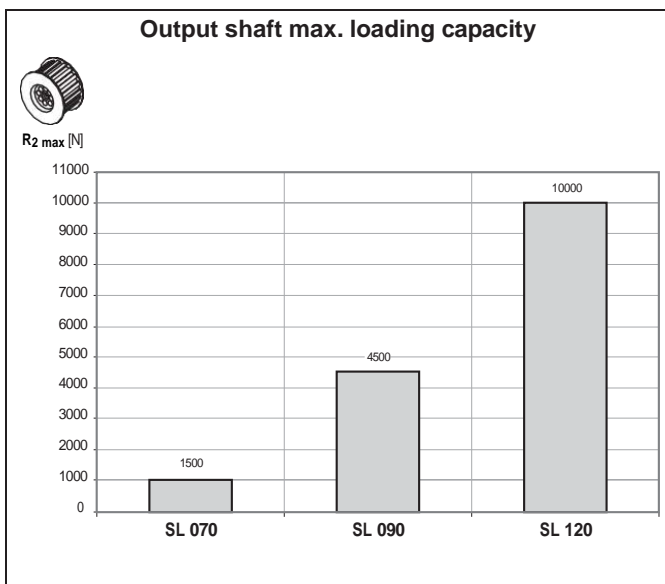

9.1 ORDERING CODE

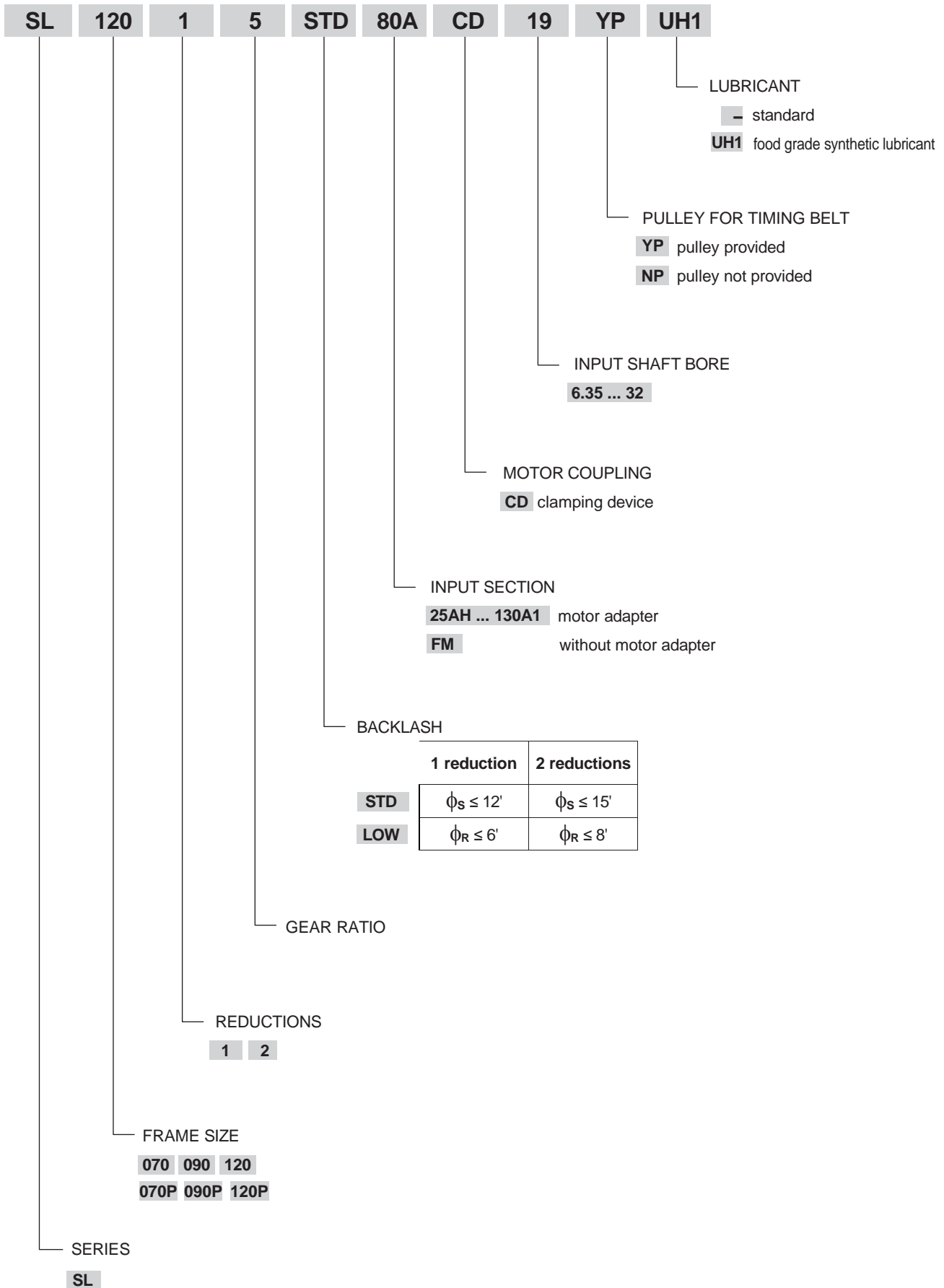

9.2 DIMENSIONS AND TECHNICAL SPECIFICATIONS

SL 070

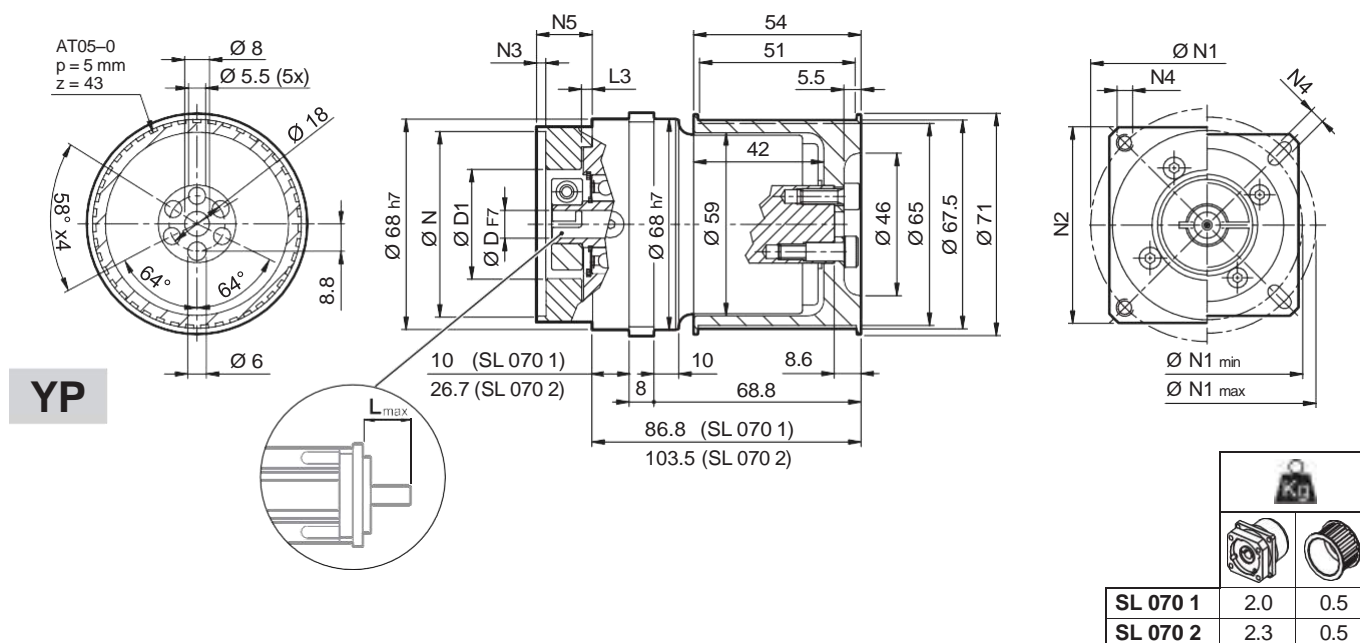

											N	N1		N2	N3	N4	N5	L _{max}
	D											min	max					
25AH	6.35	7	8	9	9.52	-	-	-	-	-	25	39	56					
26AH	6.35	7	8	9	9.52	-	-	-	-	-	26	39	56					
28AH	6.35	7	8	9	9.52	-	-	-	-	-	28	39	56					
30AH	6.35	7	8	9	9.52	-	-	-	-	-	30	39	56					
32AH	6.35	7	8	9	9.52	-	-	-	-	-	32	39	56	65	3.5	4.5	25	25
34AH	6.35	7	8	9	9.52	-	-	-	-	-	34	40	56					
36AH	6.35	7	8	9	9.52	-	-	-	-	-	36	42	56					
39AH	6.35	7	8	9	9.52	-	-	-	-	-	39	45	56					
40AH	6.35	7	8	9	9.52	-	-	-	-	-	40	46	56					
38B	6.35	7	8	9	9.52	10	11	12	12.7	-	38.1	66.6	60	3	M4x10	18	25	
40B	6.35	7	8	9	9.52	10	11	12	12.7	-	40	63	60	3	M4x10	18	25	
50A	6.35	7	8	9	9.52	10	11	12	12.7	-	50	60	60	3	M4x10	18	25	
50B	6.35	7	8	9	9.52	10	11	12	12.7	14	50	65	60	3	M5x12	23	30	
50BH	6.35	7	8	9	9.52	10	11	12	12.7	14	50	65	65	3	5.5	25	32	
50C	6.35	7	8	9	9.52	10	11	12	12.7	14	50	70	60	3	M4x10	23	30	
55MH	6.35	7	8	9	9.52	10	11	12	12.7	-	55	80	65	2	5.5	16	23	
60A	6.35	7	8	9	9.52	10	11	12	12.7	-	60	75	65	3	M5x12	18	25	
60A1	6.35	7	8	9	9.52	10	11	12	12.7	14	60	75	65	3	M5x12	23	30	
60B	6.35	7	8	9	9.52	10	11	12	12.7	14	60	85	75	3	M5x12	23	30	
60C	6.35	7	8	9	9.52	10	11	12	12.7	14	60	90	75	3	M5x12	23	30	
70A	6.35	7	8	9	9.52	10	11	12	12.7	14	70	85	75	3	M6x15	23	30	
70B	6.35	7	8	9	9.52	10	11	12	12.7	14	70	90	75	5	M5x12	23	30	
73A	6.35	7	8	9	9.52	10	11	12	12.7	14	73	98.4	85	3	M5x12	25	32	
80A	6.35	7	8	9	9.52	10	11	12	12.7	14	80	100	85	3	M6x15	23	30	

* Applies for timing belt application

SL 070

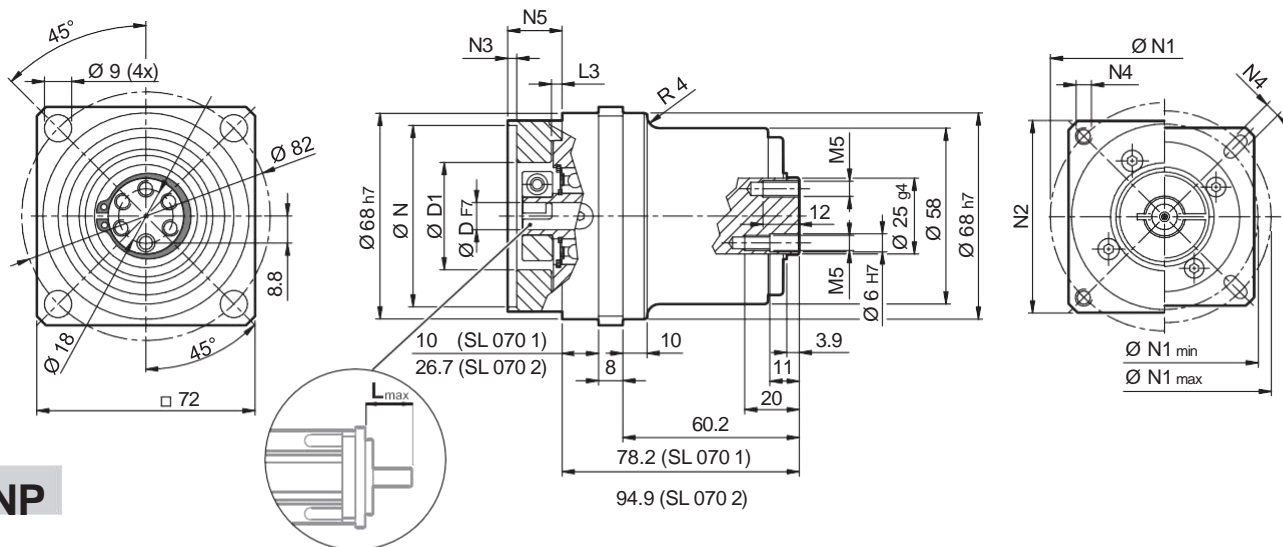

NP

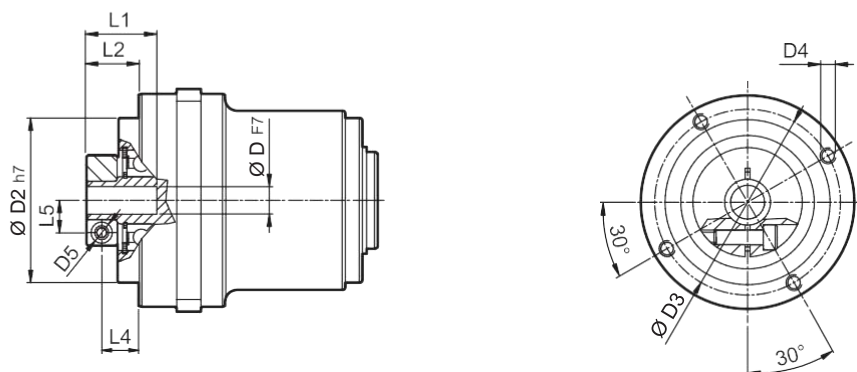

FM

D				D1	D2	D3	D4	D5	L1	L2	L3	L4	L5
6.35	7			32.5	50	42.5	M4x8	M4	21.7	13.2	3	8.2	8
8	9	9.52	10	32.5	50	42.5	M4x8	M4	21.7	13.2	3	8.2	9
11	12	12.7		35.5	50	42.5	M4x8	M4	22	13.5	3	8.5	11
14				35.5	50	42.5	M4x8	M4	25	17	3	10.2	11.5

TS

i	M _{n2} [Nm]	M _{a2} [Nm]	M _{p2} [Nm]	n ₁ [min ⁻¹]	n _{1 max} [min ⁻¹]	φ _S [arcmin]	φ _R [arcmin]	C _t Nm arcmin	R _{2 max} * [N]	A _{2 max} [N]	η %	J _G [kgcm ²]		3.86
												D		
SL 070 1_3	18	30	60	3300	4000	12'	6'	6.5	3500	1600	97	6 ... 9.52	11 ... 14	
SL 070 1_4	25	35	70	3500	5000	12'	6'	6.5	3500	1600	97	0.09	0.11	
SL 070 1_5	25	35	70	3500	5000	12'	6'	6.5	3500	1600	97	0.07	0.09	
SL 070 1_7	25	35	70	3500	5000	12'	6'	6.5	3500	1600	97	0.05	0.07	
SL 070 1_10	18	30	60	4000	6000	12'	6'	6.5	3500	1600	97	0.04	0.06	
SL 070 2_9	18	30	60	3300	4000	15'	8'	6	3500	1600	94	0.11	0.13	
SL 070 2_12	25	35	70	3300	4000	15'	8'	6	3500	1600	94	0.10	0.13	
SL 070 2_15	25	35	70	3300	4000	15'	8'	6	3500	1600	94	0.10	0.12	
SL 070 2_16	25	35	70	3500	5000	15'	8'	6	3500	1600	94	0.07	0.09	
SL 070 2_20	25	35	70	3500	5000	15'	8'	6	3500	1600	94	0.06	0.08	
SL 070 2_25	25	35	70	3500	5000	15'	8'	6	3500	1600	94	0.06	0.08	
SL 070 2_28	25	35	70	4000	6000	15'	8'	6	3500	1600	94	0.05	0.07	
SL 070 2_30	18	30	60	4000	6000	15'	8'	6	3500	1600	94	0.04	0.06	
SL 070 2_35	25	35	70	4000	6000	15'	8'	6	3500	1600	94	0.05	0.07	
SL 070 2_40	25	35	70	4000	6000	15'	8'	6	3500	1600	94	0.04	0.06	
SL 070 2_50	25	35	70	4000	6000	15'	8'	6	3500	1600	94	0.04	0.06	
SL 070 2_70	25	35	70	4000	6000	15'	8'	6	3500	1600	94	0.04	0.06	
SL 070 2_100	18	30	60	4000	6000	15'	8'	6	3500	1600	94	0.04	0.06	

Please contact us for different motor adapters and input shaft bore.

SL 090

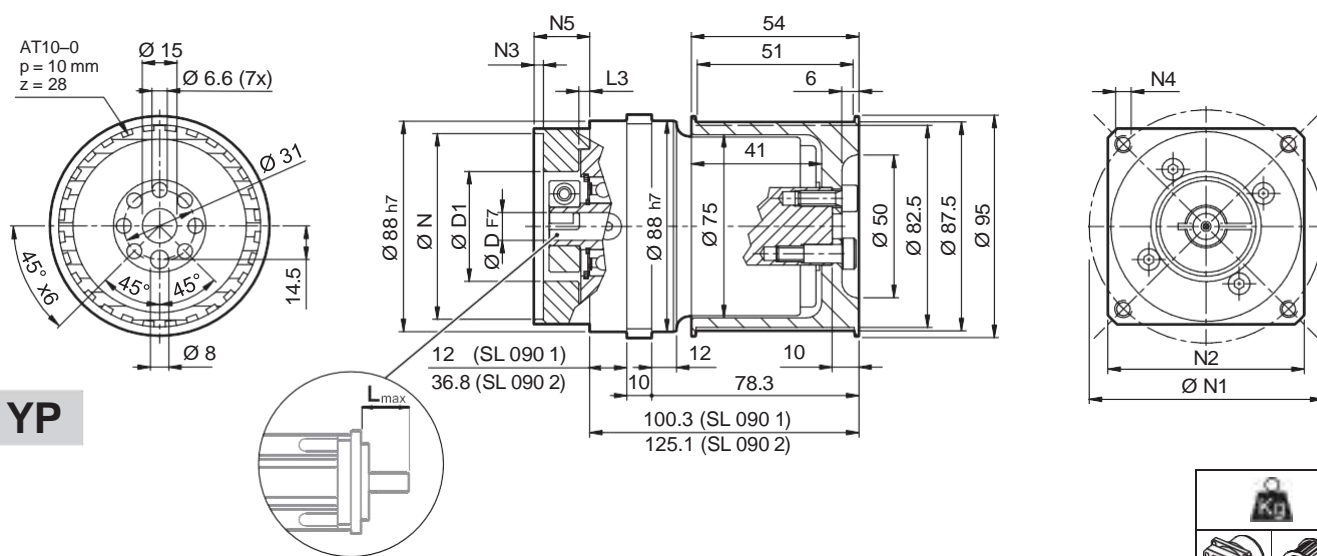

SL 090 1	3.6	0.8
SL 090 2	4.7	0.8

												N	N1	N2	N3	N4	N5	L_{max}
	9	9.52	11	12	12.7	14	-	-	-	-	-							
40B1	9	9.52	11	12	12.7	14	-	-	-	-	-	40	63	80	4	M4x10	34	40
45A	9	9.52	11	12	12.7	-	-	-	-	-	-	45	63	80	4	M4x10	34	40
50B1	9	9.52	11	12	12.7	14	-	-	-	-	-	50	65	80	4	M5x16	34	40
50BH1	9	9.52	11	12	12.7	14	-	-	-	-	-	50	65	80	4	5.5	34	40
50C1	9	9.52	11	12	12.7	14	-	-	-	-	-	50	70	80	4	M4x10	34	40
50D	9	9.52	11	12	12.7	14	-	-	-	-	-	50	95	80	4	M6x10	34	40
55A	9	9.52	11	12	12.7	14	15.875	16	17	19	19.05	55.5	125.7	105	4	M6x16	34	40
60A2	9	9.52	11	12	12.7	14	-	-	-	-	-	60	75	80	4	M5x16	34	40
60AH2	9	9.52	11	12	12.7	14	-	-	-	-	-	60	75	90	4	5.5	34	40
60B1	9	9.52	11	12	12.7	14	15.875	16	-	-	-	60	85	80	4	M5x16	34	40
60C1	9	9.52	11	12	12.7	14	15.875	16	-	-	-	60	90	80	4	M5x16	34	40
70A1	9	9.52	11	12	12.7	14	15.875	16	17	19	19.05	70	85	80	4	M6x20	34	40
70AH1	9	9.52	11	12	12.7	14	15.875	16	17	19	19.05	70	85	90	4	6.5	34	40
70B1	9	9.52	11	12	12.7	14	15.875	16	17	19	19.05	70	90	80	4	M5x16	34	40
73A1	9	9.52	11	12	12.7	14	-	-	-	-	-	73	98.4	85	4	M5x16	34	40
80A1	9	9.52	11	12	12.7	14	15.875	16	17	19	19.05	80	100	90	4	M6x16	34	40
95A	9	9.52	11	12	12.7	14	15.875	16	17	19	19.05	95	115	100	4	M8x20	34	40
95B	9	9.52	11	12	12.7	14	15.875	16	17	19	19.05	95	130	115	4	M8x20	34	40
110A	9	9.52	11	12	12.7	14	15.875	16	17	19	19.05	110	130	115	4	M8x20	34	40
110B	9	9.52	11	12	12.7	14	15.875	16	17	19	19.05	110	145	120	6.5	M8x20	44	50
110B1	9	9.52	11	12	12.7	14	15.875	16	17	19	19.05	110	145	120	6.5	M8x20	54	60

* Applies for timing belt application

SL 090

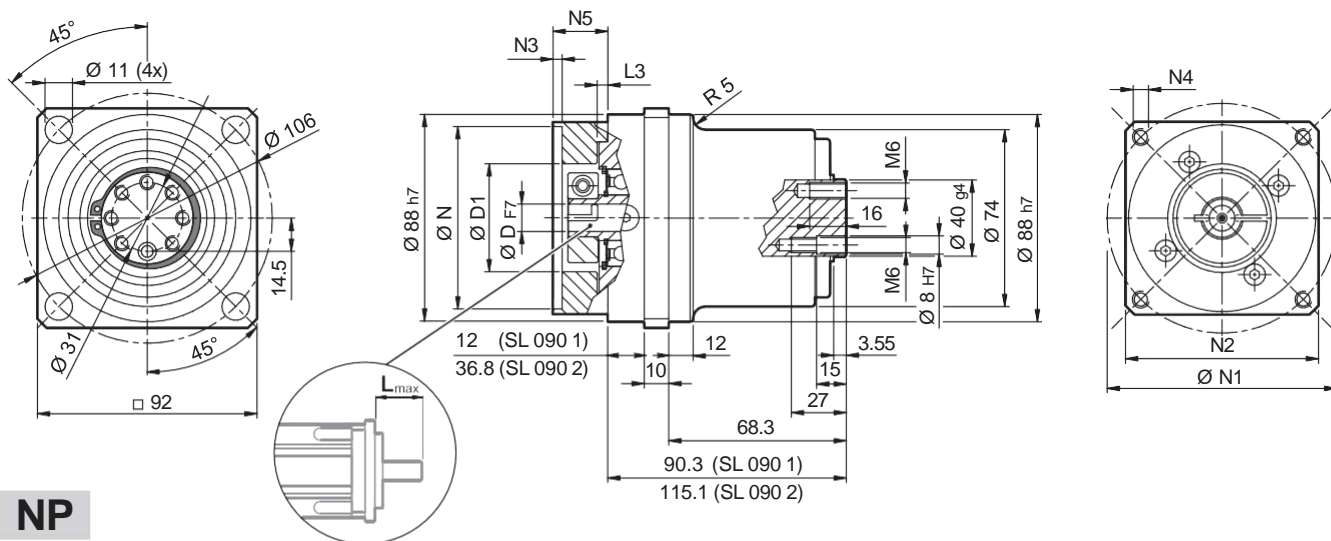

NP

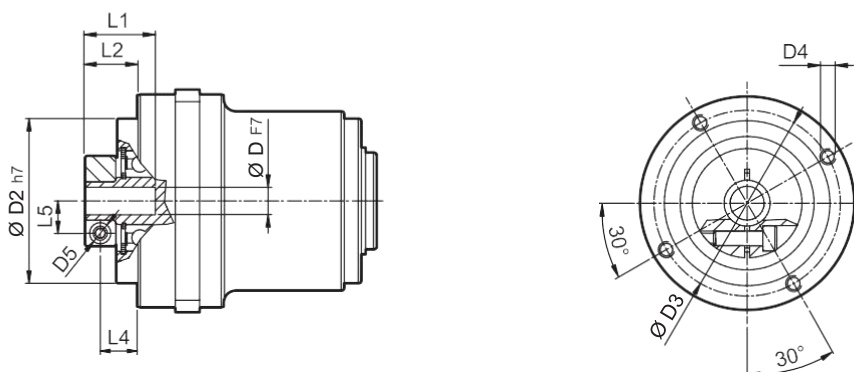

FM

				D1	D2	D3	D4	D5	L1	L2	L3	L4	L5
9	9.52			38	68	76.5	M6x10	M6	34	26.8	9.5	18.8	10.5
11	12	12.7		52	68	76.5	M6x10	M6	34	26.8	9.5	18.8	12.5
14	15.875	16	17	48	68	76.5	M6x10	M6	34	26.8	9.5	18.8	14.5
19	19.05			51	68	76.5	M6x10	M6	34	26.8	9.5	18.8	16.5

TS

	i	M_{n2} [Nm]	M_{a2} [Nm]	M_{p2} [Nm]	n_1 [min ⁻¹]	n_{1max} [min ⁻¹]	ϕ_S [arcmin]	ϕ_R [arcmin]	C_t $\frac{Nm}{arcmin}$	R_{2max}^* [N]	A_{2max} [N]	η %	J_G [kgcm ²]		
SL 090 1_3		37	70	150	2900	3500	12'	6'	12	4500	2000	97	0.72	0.81	10.95
SL 090 1_4		43	80	160	3100	4500	12'	6'	12	4500	2000	97	0.49	0.58	
SL 090 1_5		43	80	160	3200	4500	12'	6'	12	4500	2000	97	0.39	0.48	
SL 090 1_7		43	80	160	4000	6000	12'	6'	12	4500	2000	97	0.31	0.40	
SL 090 1_10		37	70	150	4000	6000	12'	6'	12	4500	2000	97	0.27	0.35	
SL 090 2_9		37	70	150	2900	3500	15'	8'	11.5	4500	2000	94	0.47	0.61	
SL 090 2_12		43	80	160	2900	3500	15'	8'	11.5	4500	2000	94	0.44	0.58	
SL 090 2_15		43	80	160	2900	3500	15'	8'	11.5	4500	2000	94	0.43	0.57	
SL 090 2_16		43	80	160	3100	4500	15'	8'	11.5	4500	2000	94	0.31	0.45	
SL 090 2_20		43	80	160	3200	4500	15'	8'	11.5	4500	2000	94	0.26	0.40	
SL 090 2_25		43	80	160	3200	4500	15'	8'	11.5	4500	2000	94	0.26	0.40	
SL 090 2_28		43	80	160	4000	6000	15'	8'	11.5	4500	2000	94	0.22	0.36	
SL 090 2_30		37	70	150	4000	6000	15'	8'	11.5	4500	2000	94	0.20	0.34	
SL 090 2_35		43	80	160	4000	6000	15'	8'	11.5	4500	2000	94	0.22	0.36	
SL 090 2_40		43	80	160	4000	6000	15'	8'	11.5	4500	2000	94	0.20	0.34	
SL 090 2_50		43	80	160	4000	6000	15'	8'	11.5	4500	2000	94	0.20	0.34	
SL 090 2_70		43	80	160	4000	6000	15'	8'	11.5	4500	2000	94	0.20	0.34	
SL 090 2_100		37	70	150	4000	6000	15'	8'	11.5	4500	2000	94	0.19	0.34	

Please contact us for different motor adapters and input shaft bore.

SL 120

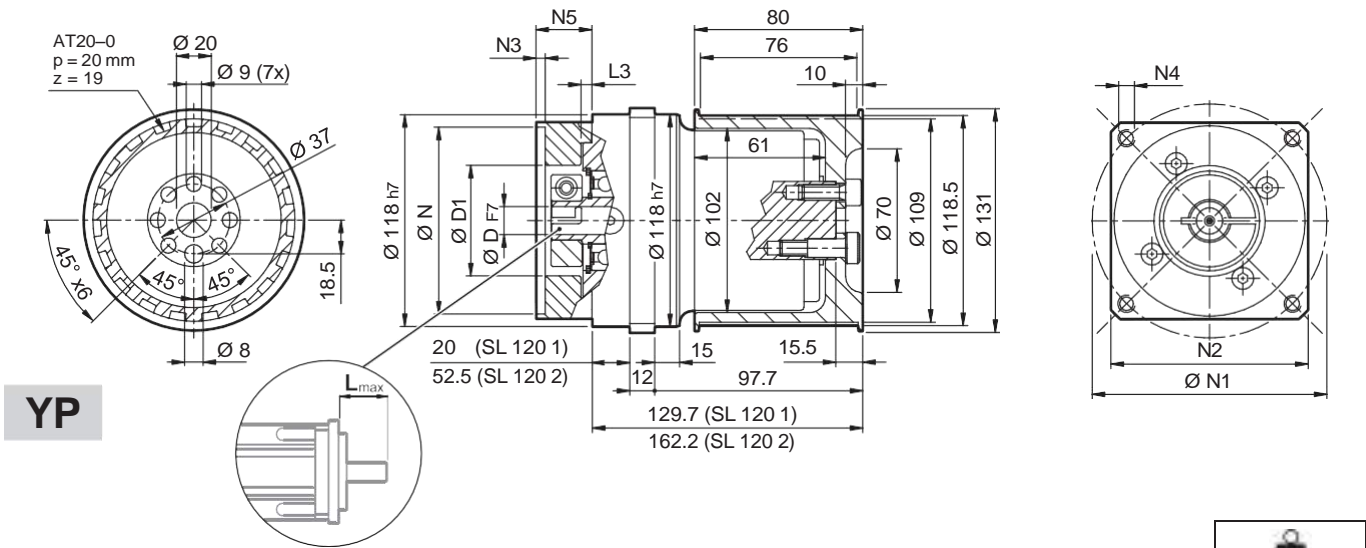

SL 120 1	8.4	2.6
SL 120 2	10.9	2.6

SL

									N	N1	N2	N3	N4	N5	L _{max}	
50D	14	15	15.875	16	19	-	-	-	-	50	95	100	5	M6x14	28	40
55A	14	15	15.875	16	19	-	-	-	-	55.5	125.7	105	5	M6x16	28	40
60A2	14	15	15.875	16	19	-	-	-	-	60	75	100	5	M5x14	28	40
60AH2	14	15	15.875	16	19	-	-	-	-	60	75	100	5	6.5	33	40
60B1	14	15	15.875	16	19	-	-	-	-	60	85	100	6.5	M5x14	28	40
70A1	14	15	15.875	16	19	-	-	-	-	70	85	100	5	M6x14	28	40
70AH1	14	15	15.875	16	19	-	-	-	-	70	85	100	5	6	33	40
70B1	14	15	15.875	16	19	-	-	-	-	70	90	100	6.5	M5x12	28	40
80A1	14	15	15.875	16	19	-	-	-	-	80	100	100	5	M6x16	28	40
80AH1	14	15	15.875	16	19	-	-	-	-	80	100	100	5	6.5	28	40
95A	14	15	15.875	16	19	-	-	-	-	95	115	100	5	M8x18	28	40
95A1	14	15	15.875	16	19	22	24	-	-	95	115	100	5	M8x18	38	50
95B	14	15	15.875	16	19	-	-	-	-	95	130	115	5	M8x18	28	40
110A	14	15	15.875	16	19	-	-	-	-	110	130	115	5	M8x18	28	40
110A1	14	15	15.875	16	19	22	24	-	-	110	130	115	6.5	M8x20	38	50
110B	14	15	15.875	16	19	22	24	-	-	110	145	120	6.5	M8x20	38	50
110B1	14	15	15.875	16	19	22	24	28	-	110	145	120	6.5	M8x20	48	60
130A	14	15	15.875	16	19	22	24	-	-	130	165	140	6.5	M10x20	38	50
130A1	14	15	15.875	16	19	22	24	28	32	130	165	140	6.5	M10x25	48	60

* Applies for timing belt application

SL 120

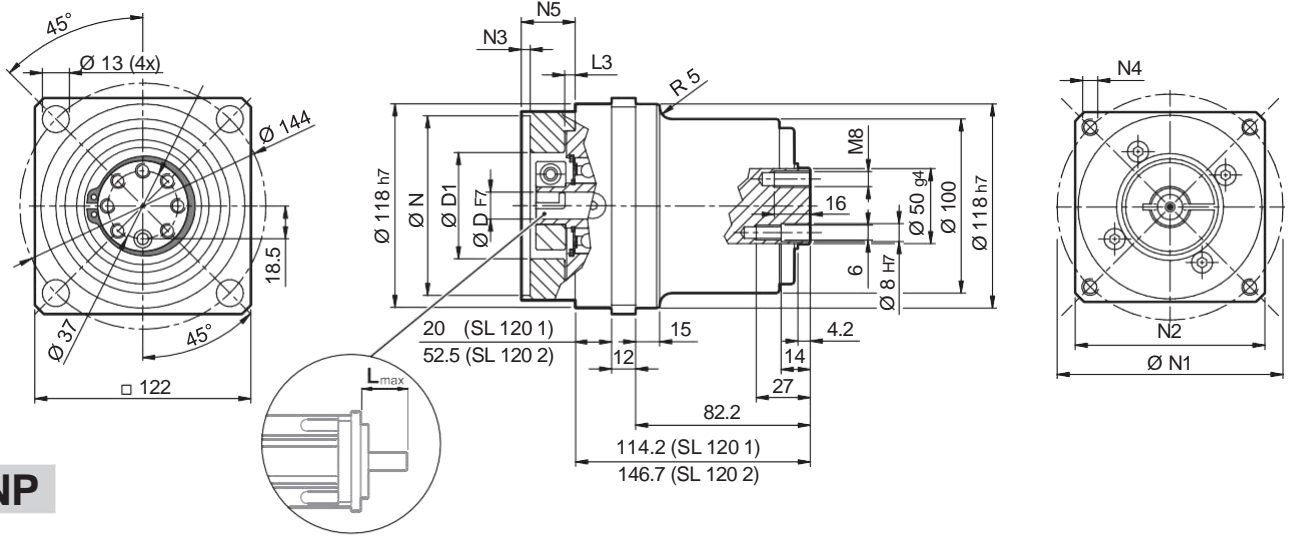

NP

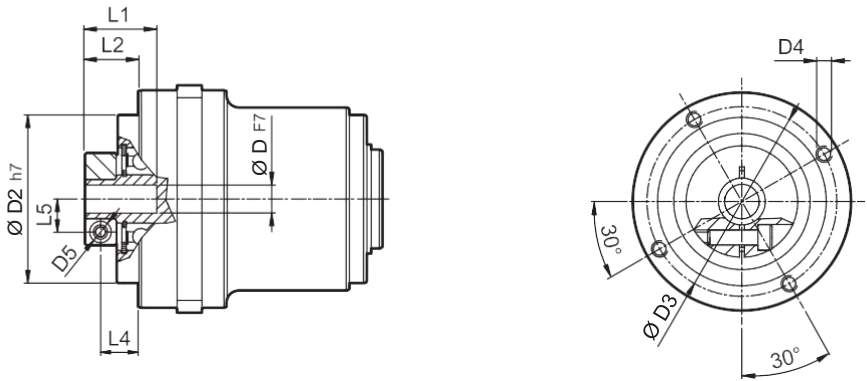

FM

D				D1	D2	D3	D4	D5	L1	L2	L3	L4	L5
14	15	15.875	16	48	90	98	M6x15	M6	33.5	20	7.6	12.5	14.5
19				51	90	98	M6x15	M6	33.5	20	7.6	12.5	16.5
22	24			56.5	90	98	M6x15	M6	36.5	23	7.6	14	19
28				70	90	98	M6x15	M8	36.5	23	7.6	14	22.5
32				71	90	98	M6x15	M8	38	24.5	7.6	15.5	24.5

 i	M_{n2}	M_{a2}	M_{p2}	n_1	$n_{1 \max}$	ϕ_S	ϕ_R	C_t	$R_{2 \max}^*$	$A_{2 \max}$	η	J_G [kgcm ²]			
												D	14 ... 19	22 ; 24	
SL 120 1 3	95	160	300	2500	3500	12'	6'	45	10000	4500	97	2.18	2.81	3.25	50.62
SL 120 1 4	110	190	360	2800	4500	12'	6'	45	10000	4500	97	1.30	1.93	2.37	
SL 120 1 5	110	190	360	3000	4500	12'	6'	45	10000	4500	97	0.96	1.59	2.03	
SL 120 1 7	110	190	360	3500	4500	12'	6'	45	10000	4500	97	0.66	1.28	1.72	
SL 120 1 10	95	160	300	3500	5000	12'	6'	45	10000	4500	97	0.49	1.11	1.55	
SL 120 2 9	95	160	300	2500	3500	15'	8'	40	10000	4500	94	1.61	2.20	2.57	
SL 120 2 12	110	190	360	2500	3500	15'	8'	40	10000	4500	94	1.51	2.10	2.47	
SL 120 2 15	110	190	360	2500	3500	15'	8'	40	10000	4500	94	1.47	2.06	2.43	
SL 120 2 16	110	190	360	2800	4500	15'	8'	40	10000	4500	94	0.92	1.52	1.88	
SL 120 2 20	110	190	360	3000	4500	15'	8'	40	10000	4500	94	0.90	1.50	1.86	
SL 120 2 25	110	190	360	3000	4500	15'	8'	40	10000	4500	94	0.71	1.30	1.67	
SL 120 2 28	110	190	360	3500	5000	15'	8'	40	10000	4500	94	0.54	1.13	1.50	
SL 120 2 30	95	160	300	3500	5000	15'	8'	40	10000	4500	94	0.44	1.04	1.40	
SL 120 2 35	110	190	360	3500	5000	15'	8'	40	10000	4500	94	0.53	1.13	1.49	
SL 120 2 40	110	190	360	3500	5000	15'	8'	40	10000	4500	94	0.43	1.03	1.39	
SL 120 2 50	110	190	360	3500	5000	15'	8'	40	10000	4500	94	0.43	1.02	1.39	
SL 120 2 70	110	190	360	3500	5000	15'	8'	40	10000	4500	94	0.42	1.02	1.38	
SL 120 2 100	95	160	300	3500	5000	15'	8'	40	10000	4500	94	0.42	1.02	1.38	

Please contact us for different motor adapters and input shaft bore.

SL 070P

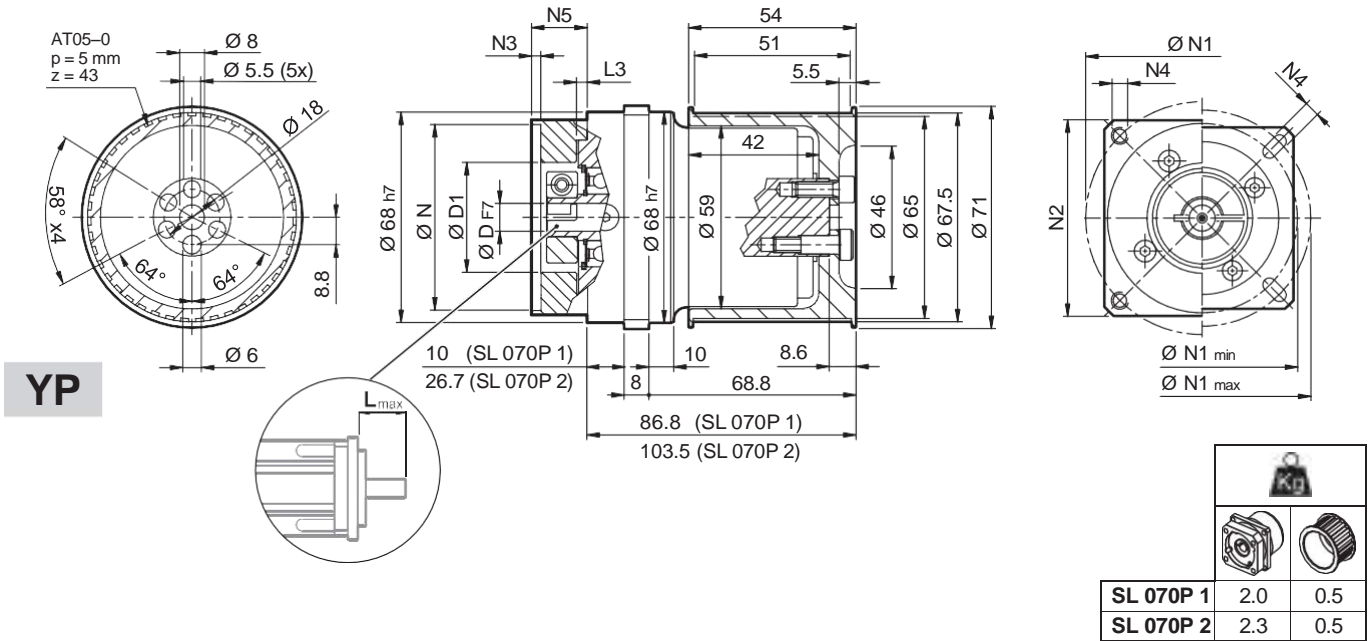

TS

											N	N1		N2	N3	N4	N5	L _{max}
	D											min	max					
25AH	6.35	7	8	9	9.52	-	-	-	-	-	25	39	56					
26AH	6.35	7	8	9	9.52	-	-	-	-	-	26	39	56					
28AH	6.35	7	8	9	9.52	-	-	-	-	-	28	39	56					
30AH	6.35	7	8	9	9.52	-	-	-	-	-	30	39	56					
32AH	6.35	7	8	9	9.52	-	-	-	-	-	32	39	56	65	3.5	4.5	25	25
34AH	6.35	7	8	9	9.52	-	-	-	-	-	34	40	56					
36AH	6.35	7	8	9	9.52	-	-	-	-	-	36	42	56					
39AH	6.35	7	8	9	9.52	-	-	-	-	-	39	45	56					
40AH	6.35	7	8	9	9.52	-	-	-	-	-	40	46	56					
38B	6.35	7	8	9	9.52	10	11	12	12.7	-	38.1	66.6	60	3	M4x10	18	25	
40B	6.35	7	8	9	9.52	10	11	12	12.7	-	40	63	60	3	M4x10	18	25	
50A	6.35	7	8	9	9.52	10	11	12	12.7	-	50	60	60	3	M4x10	18	25	
50B	6.35	7	8	9	9.52	10	11	12	12.7	14	50	65	60	3	M5x12	23	30	
50BH	6.35	7	8	9	9.52	10	11	12	12.7	14	50	65	65	3	5.5	25	32	
50C	6.35	7	8	9	9.52	10	11	12	12.7	14	50	70	60	3	M4x10	23	30	
55MH	6.35	7	8	9	9.52	10	11	12	12.7	-	55	80	65	2	5.5	16	23	
60A	6.35	7	8	9	9.52	10	11	12	12.7	-	60	75	65	3	M5x12	18	25	
60A1	6.35	7	8	9	9.52	10	11	12	12.7	14	60	75	65	3	M5x12	23	30	
60B	6.35	7	8	9	9.52	10	11	12	12.7	14	60	85	75	3	M5x12	23	30	
60C	6.35	7	8	9	9.52	10	11	12	12.7	14	60	90	75	3	M5x12	23	30	
70A	6.35	7	8	9	9.52	10	11	12	12.7	14	70	85	75	3	M6x15	23	30	
70B	6.35	7	8	9	9.52	10	11	12	12.7	14	70	90	75	5	M5x12	23	30	
73A	6.35	7	8	9	9.52	10	11	12	12.7	14	73	98.4	85	3	M5x12	25	32	
80A	6.35	7	8	9	9.52	10	11	12	12.7	14	80	100	85	3	M6x15	23	30	

* Applies for timing belt application

SL 070P

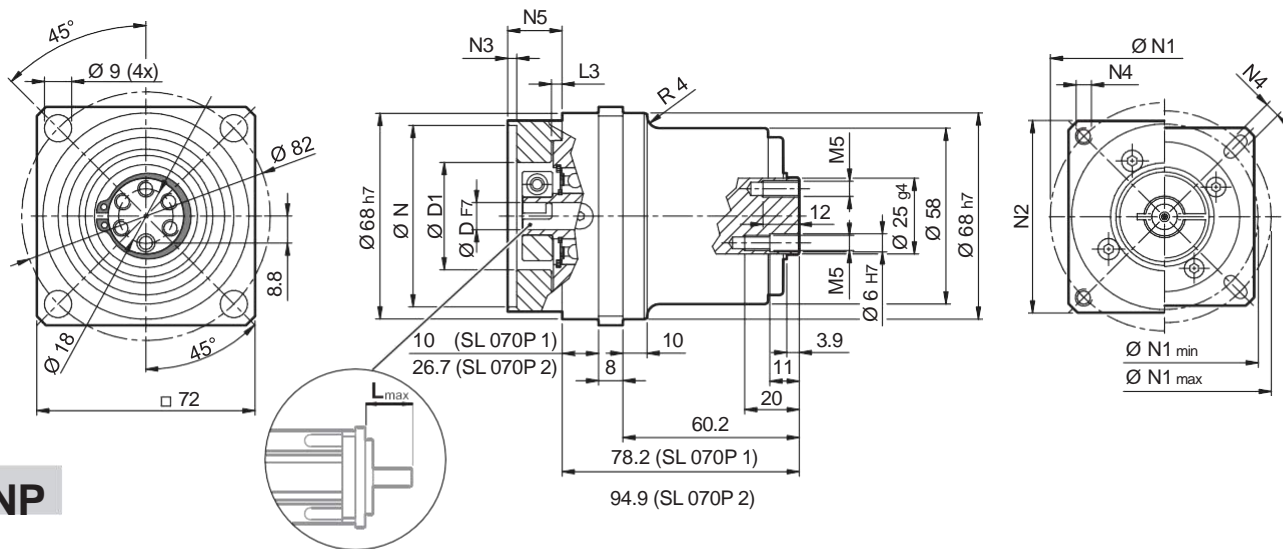

NP

FM

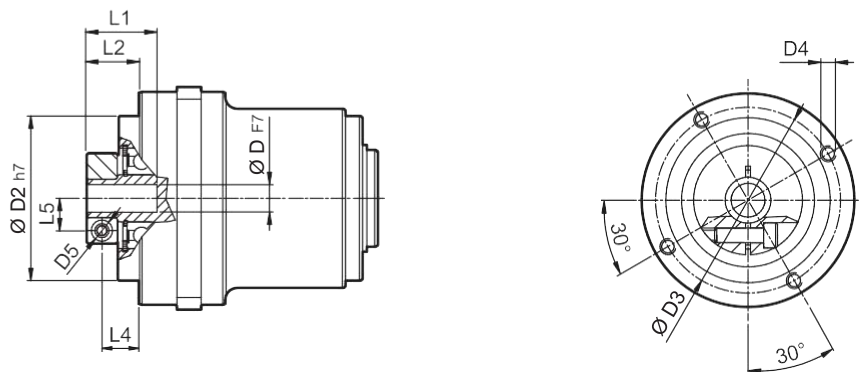

D				D1	D2	D3	D4	D5	L1	L2	L3	L4	L5
6.35	7			32.5	50	42.5	M4x8	M4	21.7	13.2	3	8.2	8
8	9	9.52	10	32.5	50	42.5	M4x8	M4	21.7	13.2	3	8.2	9
11	12	12.7		35.5	50	42.5	M4x8	M4	22	13.5	3	8.5	11
14				35.5	50	42.5	M4x8	M4	25	17	3	10.2	11.5

SL

i	M _{n2} [Nm]	M _{a2} [Nm]	M _{p2} [Nm]	n ₁ [min ⁻¹]	n _{1 max} [min ⁻¹]	φ _S [arcmin]	φ _R [arcmin]	C _t Nm/arcmin	R _{2 max} * [N]	A _{2 max} [N]	η %	J _G [kgcm ²]		3.86
												D	6 ... 9.52	
SL 070P 1 3	29	55	60	3300	4000	12'	6'	6.5	3500	1600	97	0.14	0.16	3.86
SL 070P 1 4	30	45	70	3500	5000	12'	6'	6.5	3500	1600	97	0.09	0.11	
SL 070P 1 5	28	40	70	3500	5000	12'	6'	6.5	3500	1600	97	0.07	0.09	
SL 070P 1 7	28	40	70	4000	5000	12'	6'	6.5	3500	1600	97	0.05	0.07	
SL 070P 1 10	20	33	60	4000	6000	12'	6'	6.5	3500	1600	97	0.04	0.06	
SL 070P 2 9	29	55	60	3300	4000	15'	8'	6	3500	1600	94	0.11	0.13	
SL 070P 2 12	29	55	70	3300	4000	15'	8'	6	3500	1600	94	0.10	0.13	
SL 070P 2 15	29	55	70	3300	4000	15'	8'	6	3500	1600	94	0.10	0.12	
SL 070P 2 16	30	45	70	3500	5000	15'	8'	6	3500	1600	94	0.07	0.09	
SL 070P 2 20	30	45	70	3500	5000	15'	8'	6	3500	1600	94	0.06	0.08	
SL 070P 2 25	30	45	70	3500	5000	15'	8'	6	3500	1600	94	0.06	0.08	
SL 070P 2 28	30	45	70	4000	6000	15'	8'	6	3500	1600	94	0.05	0.07	
SL 070P 2 30	29	55	60	4000	6000	15'	8'	6	3500	1600	94	0.04	0.06	
SL 070P 2 35	30	45	70	4000	6000	15'	8'	6	3500	1600	94	0.05	0.07	
SL 070P 2 40	30	45	70	4000	6000	15'	8'	6	3500	1600	94	0.04	0.06	
SL 070P 2 50	30	45	70	4000	6000	15'	8'	6	3500	1600	94	0.04	0.06	
SL 070P 2 70	30	45	70	4000	6000	15'	8'	6	3500	1600	94	0.04	0.06	
SL 070P 2 100	20	33	60	4000	6000	15'	8'	6	3500	1600	94	0.04	0.06	

Please contact us for different motor adapters and input shaft bore.

SL 090P

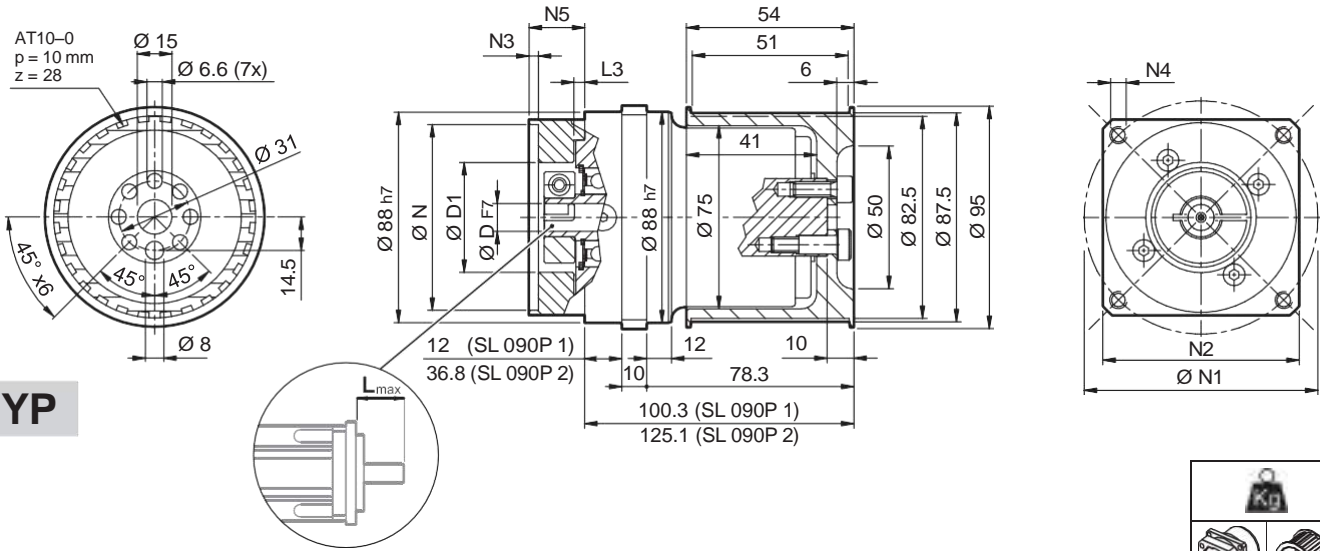

SL 090P 1	3.6	0.8
SL 090P 2	4.7	0.8

TS

												N	N1	N2	N3	N4	N5	L_{max}
40B1	9	9.52	11	12	12.7	14	-	-	-	-	-	40	63	80	4	M4x10	34	40
45A	9	9.52	11	12	12.7	-	-	-	-	-	-	45	63	80	4	M4x10	34	40
50B1	9	9.52	11	12	12.7	14	-	-	-	-	-	50	65	80	4	M5x16	34	40
50BH1	9	9.52	11	12	12.7	14	-	-	-	-	-	50	65	80	4	5.5	34	40
50C1	9	9.52	11	12	12.7	14	-	-	-	-	-	50	70	80	4	M4x10	34	40
50D	9	9.52	11	12	12.7	14	-	-	-	-	-	50	95	80	4	M6x10	34	40
55A	9	9.52	11	12	12.7	14	15.875	16	17	19	19.05	55.5	125.7	105	4	M6x16	34	40
60A2	9	9.52	11	12	12.7	14	-	-	-	-	-	60	75	80	4	M5x16	34	40
60AH2	9	9.52	11	12	12.7	14	-	-	-	-	-	60	75	90	4	5.5	34	40
60B1	9	9.52	11	12	12.7	14	15.875	16	-	-	-	60	85	80	4	M5x16	34	40
60C1	9	9.52	11	12	12.7	14	15.875	16	-	-	-	60	90	80	4	M5x16	34	40
70A1	9	9.52	11	12	12.7	14	15.875	16	17	19	19.05	70	85	80	4	M6x20	34	40
70AH1	9	9.52	11	12	12.7	14	15.875	16	17	19	19.05	70	85	90	4	6.5	34	40
70B1	9	9.52	11	12	12.7	14	15.875	16	17	19	19.05	70	90	80	4	M5x16	34	40
73A1	9	9.52	11	12	12.7	14	-	-	-	-	-	73	98.4	85	4	M5x16	34	40
80A1	9	9.52	11	12	12.7	14	15.875	16	17	19	19.05	80	100	90	4	M6x16	34	40
95A	9	9.52	11	12	12.7	14	15.875	16	17	19	19.05	95	115	100	4	M8x20	34	40
95B	9	9.52	11	12	12.7	14	15.875	16	17	19	19.05	95	130	115	4	M8x20	34	40
110A	9	9.52	11	12	12.7	14	15.875	16	17	19	19.05	110	130	115	4	M8x20	34	40
110B	9	9.52	11	12	12.7	14	15.875	16	17	19	19.05	110	145	120	6.5	M8x20	44	50
110B1	9	9.52	11	12	12.7	14	15.875	16	17	19	19.05	110	145	120	6.5	M8x20	54	60

* Applies for timing belt application

SL 090P

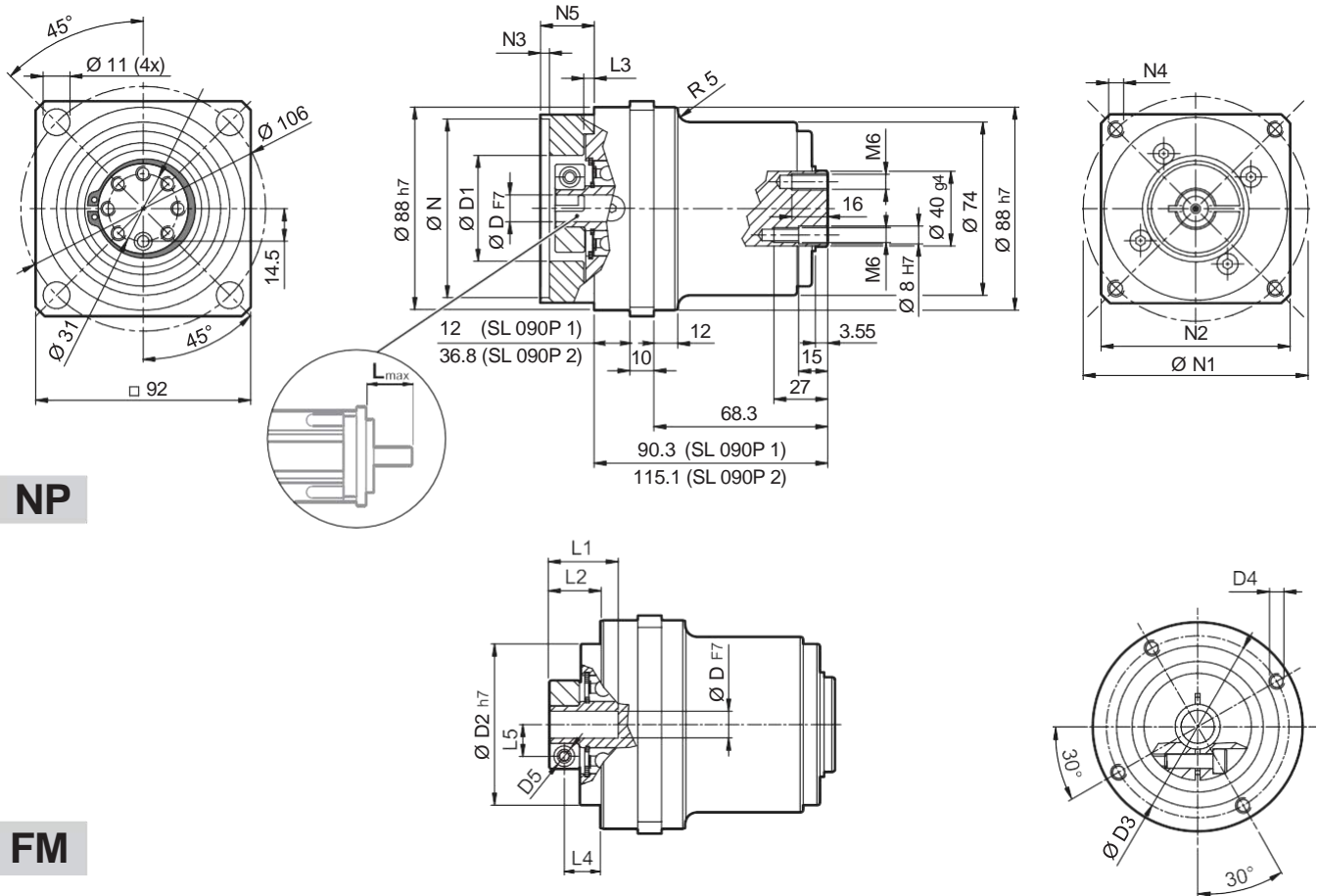

NP

FM

D	Ø 11 (4x)		Ø 106	14.5	Ø 37	92	Ø 88 h7	Ø N	Ø D1	Ø D F7	N3	N5	L3	R 5	M6	16	Ø 40 g4	Ø 8 h7	M6	Ø 74	Ø 88 h7	N4	N2	Ø N1
	9	11																						
9	9.52																							
11	12	12.7																						
14	15.875	16	17																					
19	19.05																							

TS

i	M _{n2} [Nm]	M _{a2} [Nm]	M _{p2} [Nm]	n ₁ [min ⁻¹]	n _{1 max} [min ⁻¹]	φ _S [arcmin]	φ _R [arcmin]	C _t Nm/arcmin	R _{2 max} * [N]	A _{2 max} [N]	η %	J _G [kgcm ²]		D	10.95
												9 ... 12.7	14 ... 19		
SL 090P 1_3	65	120	150	3500	4000	12'	6'	12	4500	2000	97	0.72	0.81		
SL 090P 1_4	60	110	160	3500	4000	12'	6'	12	4500	2000	97	0.49	0.58		
SL 090P 1_5	50	100	160	3200	4500	12'	6'	12	4500	2000	97	0.39	0.48		
SL 090P 1_7	50	100	160	4000	6000	12'	6'	12	4500	2000	97	0.31	0.40		
SL 090P 1_10	40	75	150	4000	6000	12'	6'	12	4500	2000	97	0.27	0.35		
SL 090P 2_9	65	120	150	3500	4000	15'	8'	11.5	4500	2000	94	0.47	0.61		
SL 090P 2_12	65	120	160	3500	4000	15'	8'	11.5	4500	2000	94	0.44	0.58		
SL 090P 2_15	65	120	160	3500	4000	15'	8'	11.5	4500	2000	94	0.43	0.57		
SL 090P 2_16	60	110	160	3500	4500	15'	8'	11.5	4500	2000	94	0.31	0.45		
SL 090P 2_20	60	110	160	3500	4500	15'	8'	11.5	4500	2000	94	0.26	0.40		
SL 090P 2_25	50	100	160	3200	4500	15'	8'	11.5	4500	2000	94	0.26	0.40		
SL 090P 2_28	50	100	160	4000	6000	15'	8'	11.5	4500	2000	94	0.22	0.36		
SL 090P 2_30	65	120	150	4000	6000	15'	8'	11.5	4500	2000	94	0.20	0.34		
SL 090P 2_35	50	100	160	4000	6000	15'	8'	11.5	4500	2000	94	0.22	0.36		
SL 090P 2_40	60	110	160	4000	6000	15'	8'	11.5	4500	2000	94	0.20	0.34		
SL 090P 2_50	50	100	160	4000	6000	15'	8'	11.5	4500	2000	94	0.20	0.34		
SL 090P 2_70	50	100	160	4000	6000	15'	8'	11.5	4500	2000	94	0.20	0.34		
SL 090P 2_100	40	75	150	4000	6000	15'	8'	11.5	4500	2000	94	0.19	0.34		

Please contact us for different motor adapters and input shaft bore.

SL 120P

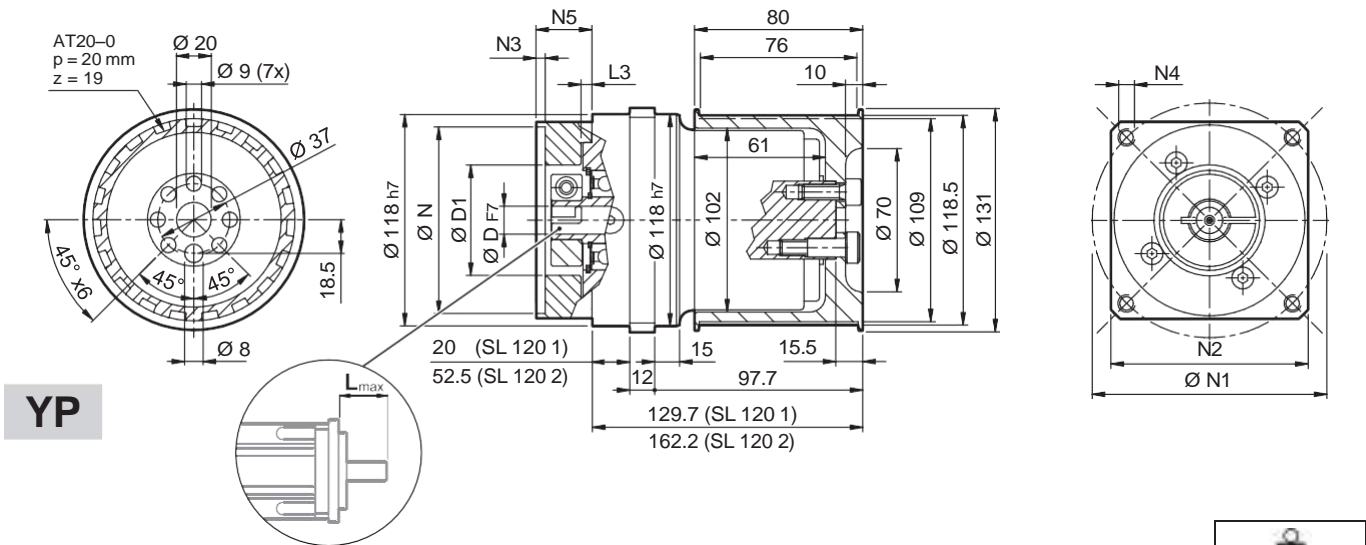

YP

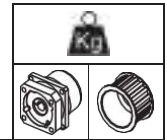

SL 120P 1	8.4	2.6	
SL 120P 2	10.9	2.6	

SL

									N	N1	N2	N3	N4	N5	L _{max}
50D	14	15	15.875	16	19	-	-	-	50	95	100	5	M6x14	28	40
55A	14	15	15.875	16	19	-	-	-	55.5	125.7	105	5	M6x16	28	40
60A2	14	15	15.875	16	19	-	-	-	60	75	100	5	M5x14	28	40
60AH2	14	15	15.875	16	19	-	-	-	60	75	100	5	6.5	33	40
60B1	14	15	15.875	16	19	-	-	-	60	85	100	6.5	M5x14	28	40
70A1	14	15	15.875	16	19	-	-	-	70	85	100	5	M6x14	28	40
70AH1	14	15	15.875	16	19	-	-	-	70	85	100	5	6	33	40
70B1	14	15	15.875	16	19	-	-	-	70	90	100	6.5	M5x12	28	40
80A1	14	15	15.875	16	19	-	-	-	80	100	100	5	M6x16	28	40
80AH1	14	15	15.875	16	19	-	-	-	80	100	100	5	6.5	28	40
95A	14	15	15.875	16	19	-	-	-	95	115	100	5	M8x18	28	40
95A1	14	15	15.875	16	19	22	24	-	95	115	100	5	M8x18	38	50
95B	14	15	15.875	16	19	-	-	-	95	130	115	5	M8x18	28	40
110A	14	15	15.875	16	19	-	-	-	110	130	115	5	M8x18	28	40
110A1	14	15	15.875	16	19	22	24	-	110	130	115	6.5	M8x20	38	50
110B	14	15	15.875	16	19	22	24	-	110	145	120	6.5	M8x20	38	50
110B1	14	15	15.875	16	19	22	24	28	110	145	120	6.5	M8x20	48	60
130A	14	15	15.875	16	19	22	24	-	130	165	140	6.5	M10x20	38	50
130A1	14	15	15.875	16	19	22	24	28	130	165	140	6.5	M10x25	48	60

* Applies for timing belt application

SL 120P

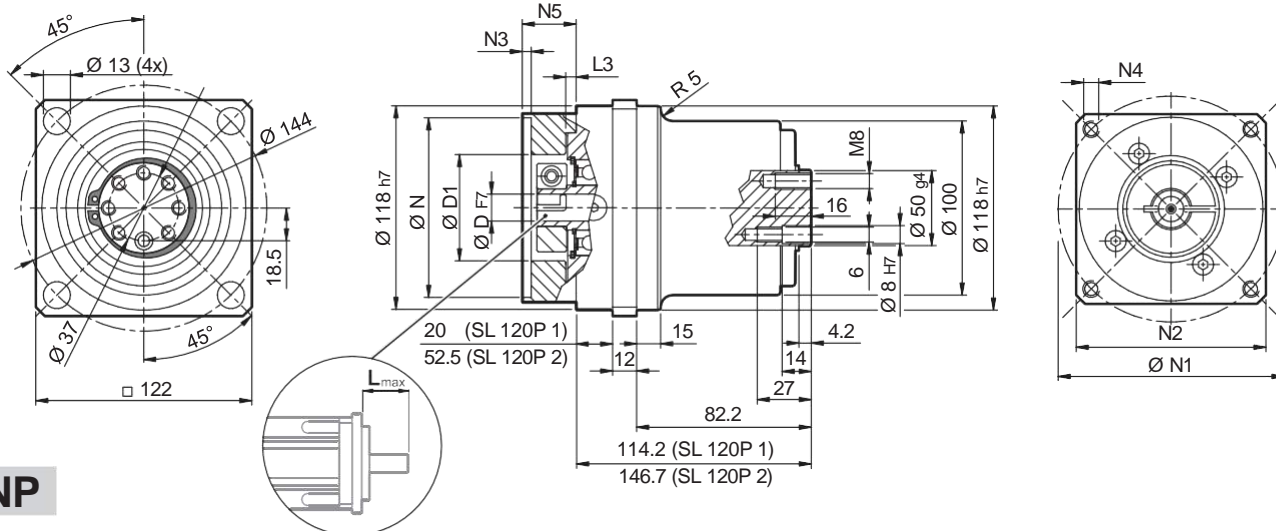

NP

FM

				D1	D2	D3	D4	D5	L1	L2	L3	L4	L5
14	15	15.875	16	48	90	98	M6x15	M6	33.5	20	7.6	12.5	14.5
19				51	90	98	M6x15	M6	33.5	20	7.6	12.5	16.5
22	24			56.5	90	98	M6x15	M6	36.5	23	7.6	14	19
28				70	90	98	M6x15	M8	36.5	23	7.6	14	22.5
32				71	90	98	M6x15	M8	38	24.5	7.6	15.5	24.5

TS

	i	M_{n2} [Nm]	M_{a2} [Nm]	M_{p2} [Nm]	n_1 [min ⁻¹]	n_{1max} [min ⁻¹]	ϕ_S [arcmin]	ϕ_R [arcmin]	C_t $\frac{Nm}{arcmin}$	R_{2max}^* [N]	A_{2max} [N]	η %	J_G [kgcm ²]			
													D	14 ... 19	22 ; 24	
SL 120P 1 3		155	280	300	3000	4000	12'	6'	45	10000	4500	97	2.18	2.81	3.25	50.62
SL 120P 1 4		155	300	360	3000	4500	12'	6'	45	10000	4500	97	1.30	1.93	2.37	
SL 120P 1 5		125	240	360	3000	4500	12'	6'	45	10000	4500	97	0.96	1.59	2.03	
SL 120P 1 7		125	240	360	3500	4500	12'	6'	45	10000	4500	97	0.66	1.28	1.72	
SL 120P 1 10		100	165	300	3500	5000	12'	6'	45	10000	4500	97	0.49	1.11	1.55	
SL 120P 2 9		155	280	300	3000	4000	15'	8'	40	10000	4500	94	1.61	2.20	2.57	
SL 120P 2 12		155	300	360	3000	4000	15'	8'	40	10000	4500	94	1.51	2.10	2.47	
SL 120P 2 15		155	300	360	3000	4000	15'	8'	40	10000	4500	94	1.47	2.06	2.43	
SL 120P 2 16		155	300	360	3000	4500	15'	8'	40	10000	4500	94	0.92	1.52	1.88	
SL 120P 2 20		155	300	360	3000	4500	15'	8'	40	10000	4500	94	0.90	1.50	1.86	
SL 120P 2 25		125	240	360	3000	4500	15'	8'	40	10000	4500	94	0.71	1.30	1.67	
SL 120P 2 28		125	240	360	3500	5000	15'	8'	40	10000	4500	94	0.54	1.13	1.50	
SL 120P 2 30		155	300	300	3500	5000	15'	8'	40	10000	4500	94	0.44	1.04	1.40	
SL 120P 2 35		125	240	360	3500	5000	15'	8'	40	10000	4500	94	0.53	1.13	1.49	
SL 120P 2 40		155	300	360	3500	5000	15'	8'	40	10000	4500	94	0.43	1.03	1.39	
SL 120P 2 50		125	240	360	3500	5000	15'	8'	40	10000	4500	94	0.43	1.02	1.39	
SL 120P 2 70		125	240	360	3500	5000	15'	8'	40	10000	4500	94	0.42	1.02	1.38	
SL 120P 2 100		100	165	300	3500	5000	15'	8'	40	10000	4500	94	0.42	1.02	1.38	

Please contact us for different motor adapters and input shaft bore.



LC Series

LC precision planetary gearboxes represent a flexible solution and valuable alternative with optimal performance and reliability levels.

The output design in line with market standards ensures great compatibility for easy retrofits and a high level of freedom in projects development.

Main benefits

- Cost effective yet powerful
- Highly reliable
- High compatibility for easy retrofits

Main features

- Nominal output torque (Nm)



- Torsional backlash (arcmin)



- Torsional stiffness (Nm/arcmin)

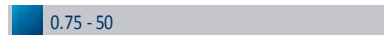

- Max tilting moment (Nm)

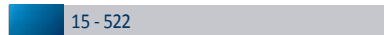

Protection class

- IP54

Frame sizes

- 050
- 070
- 090
- 120
- 155

Main options

- Input versions

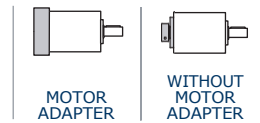

- Output shafts versions

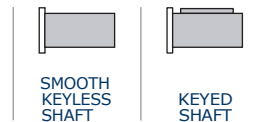

- Lubrication



- High power version (P option)



* Applies for timing belt application

10 FEATURES OF LC SERIES

Planetary gear units of the LC series belong to a range of low backlash drives very broad and complete as far as transmissible torque, gear ratios and torsional backlash.

All units are generously proportioned to run quietly and provide a long service life without maintenance requirements.

Motor mounting is an operation that can be easily conducted without the need of any particular tooling, other than that usually available in a normally equipped workshop.

- Available with either standard (STD) or reduced (LOW) backlash:
1-stage units: standard $\phi_S \leq 12'$; reduced $\phi_R \leq 6'$
2-stage units: standard $\phi_S \leq 15'$; reduced $\phi_R \leq 8'$
- Its degree of protection IP54 provides protection against dust and liquid splashes.
- Input section oil seals made from a Fluoroelastomer compound are supplied as standard.
- Noise pressure level $L_P \leq 70$ dB(A). Conditions: distance 1 m; measured without load an input speed of $n_1 = 3000 \text{ min}^{-1}$; $i=10$.
- Wide range of adapter flanges matching the most popular brands of motors
- Units are factory filled with synthetic grease to NLGI consistency class 00, in the absence of contamination the lubricant requires no periodical changes.
- Ambient temperature min -20°C , max $+30^\circ\text{C}$. For temperature higher than 30°C please consider derating factor f_T .
- Housing temperature must not exceed $T_{\text{max}} = 90^\circ\text{C}$.
- Available as Version P with higher output torque.

		Distribution of nominal torque M_{n2} [Nm]																				
	[i]	3	4	5	7	9	10	12	15	16	20	25	28	30	35	36	40	45	50	70	81	100
LC 050	10	12	12	12	12	10	-	12	12	12	12	12	12	-	12	12	-	12	-	-	10	-
LC 070	18	25	25	25	25	18	18	25	25	25	25	25	25	18	25	-	25	-	25	25	-	18
LC 070P	29	30	28	28	29	20	29	29	29	30	30	30	30	29	30	-	30	-	30	30	-	20
LC 090	37	43	43	43	37	37	43	43	43	43	43	43	43	37	43	-	43	-	43	43	-	37
LC 090P	65	60	50	50	65	40	65	65	60	60	50	50	65	50	-	60	-	50	50	-	40	
LC 120	95	110	110	110	95	95	110	110	110	110	110	110	110	95	110	-	110	-	110	110	-	95
LC 120P	155	155	125	125	155	100	155	155	155	155	125	125	125	155	125	-	155	-	125	125	-	100
LC 155	250	300	300	300	250	230	300	300	300	300	300	300	300	250	300	-	300	-	300	300	-	230

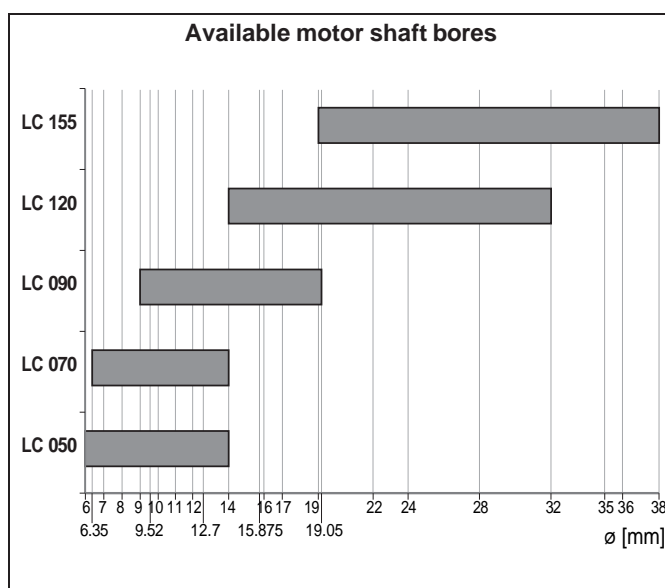
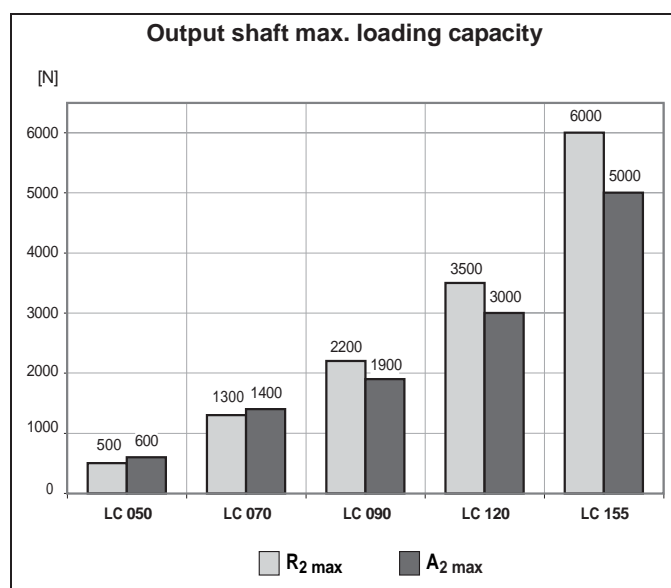

Please contact us for different motor adapters and input shaft bore.

10.1 ORDERING CODE

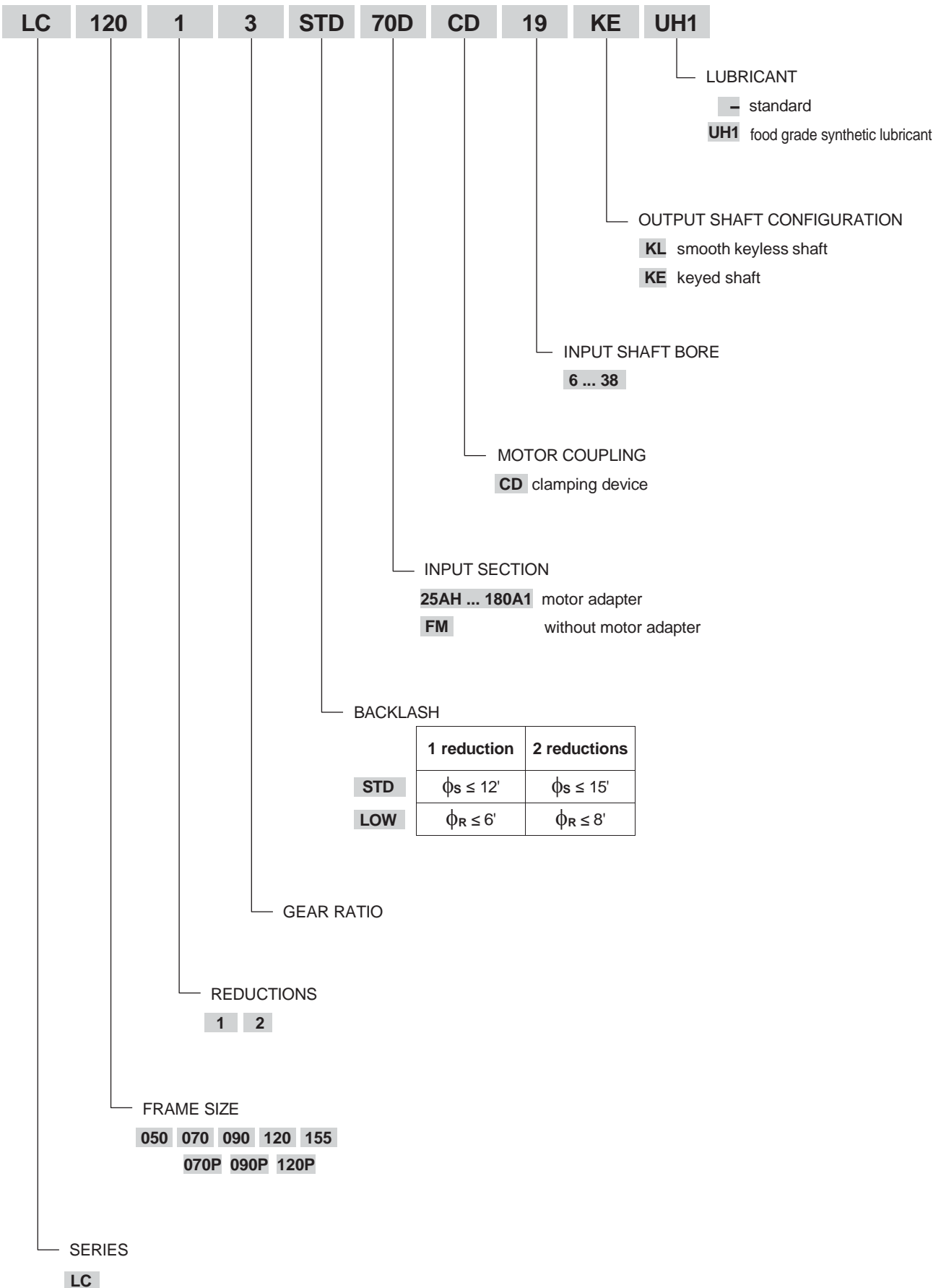

LC

* Applies for timing belt application

10.2 DIMENSIONS AND TECHNICAL SPECIFICATIONS

LC 050

25AH ... 80A

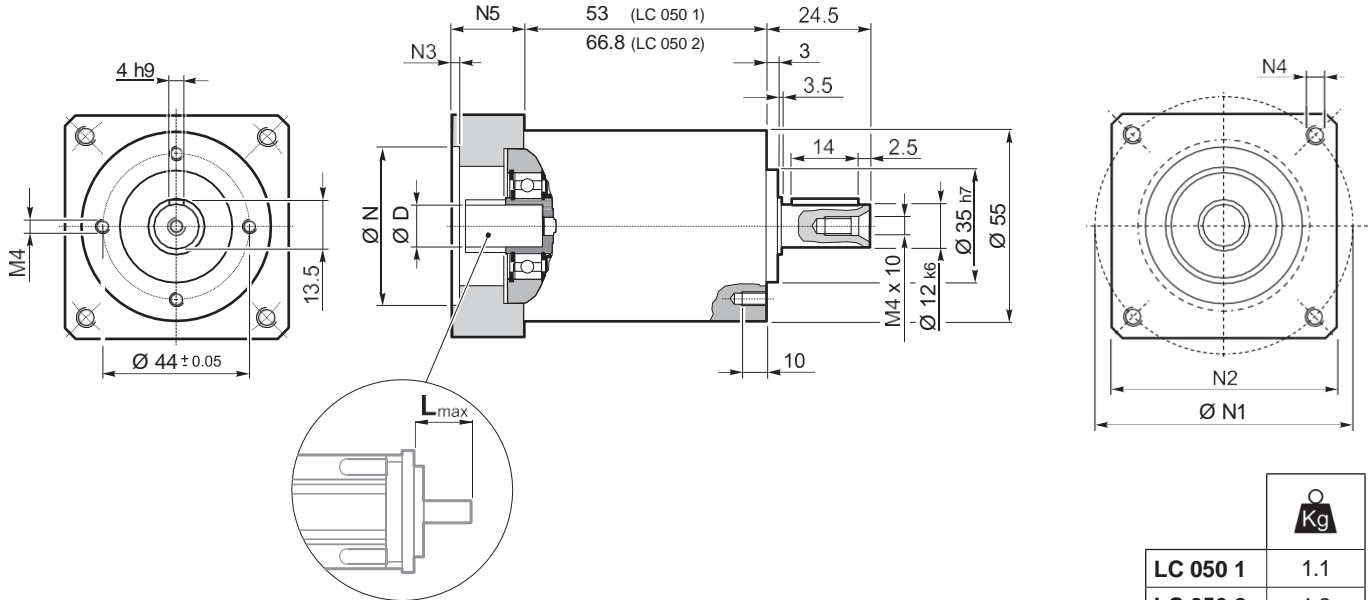

	D											N	N1		N2	N3	N4	N5	L _{max}
	6	6.35	7	8	9	9.52	-	-	-	-	-		min	max					
25AH	6	6.35	7	8	9	9.52	-	-	-	-	-	25	36	48					
26AH	6	6.35	7	8	9	9.52	-	-	-	-	-	26	36	48					
28AH	6	6.35	7	8	9	9.52	-	-	-	-	-	28	36	48					
30AH	6	6.35	7	8	9	9.52	-	-	-	-	-	30	36	48					
32AH	6	6.35	7	8	9	9.52	-	-	-	-	-	32	38	48	55	3.5	4.5	25	25
34AH	6	6.35	7	8	9	9.52	-	-	-	-	-	34	40	48					
36AH	6	6.35	7	8	9	9.52	-	-	-	-	-	36	42	48					
38AH	6	6.35	7	8	9	9.52	-	-	-	-	-	38	44	48					
40AH	6	6.35	7	8	9	9.52	-	-	-	-	-	40	46	48					
38B	6	6.35	7	8	9	9.52	10	11	12	12.7	-	38.1	66.6	60	3	M4x10	18	25	
40B	6	6.35	7	8	9	9.52	10	11	12	12.7	-	40	63	60	3	M4x10	18	25	
50A	6	6.35	7	8	9	9.52	10	11	12	12.7	-	50	60	60	3	M4x10	18	25	
50B	6	6.35	7	8	9	9.52	10	11	12	12.7	14	50	65	60	3	M5x12	23	30	
50BH	6	6.35	7	8	9	9.52	10	11	12	12.7	14	50	65	60	4	5.5	23	30	
50C	6	6.35	7	8	9	9.52	10	11	12	12.7	14	50	70	60	3	M4x10	23	30	
50MH	6	6.35	7	8	9	9.52	10	11	12	12.7	-	50	65	55	4	5.5	16	23	
60A	6	6.35	7	8	9	9.52	10	11	12	12.7	-	60	75	65	3	M5x12	18	25	
60AH	6	6.35	7	8	9	9.52	10	11	12	12.7	-	60	75	65	3	5.5	18	25	
60A1	6	6.35	7	8	9	9.52	10	11	12	12.7	14	60	75	65	3	M5x12	23	30	
60AH1	6	6.35	7	8	9	9.52	10	11	12	12.7	14	60	75	65	3	5.5	23	30	
60B	6	6.35	7	8	9	9.52	10	11	12	12.7	14	60	85	75	3	M5x12	23	30	
60C	6	6.35	7	8	9	9.52	10	11	12	12.7	14	60	90	75	3	M5x12	23	30	
70A	6	6.35	7	8	9	9.52	10	11	12	12.7	14	70	85	75	3	M6x15	23	30	
70B	6	6.35	7	8	9	9.52	10	11	12	12.7	14	70	90	75	5	M5x12	23	30	
73A	6	6.35	7	8	9	9.52	10	11	12	12.7	14	73	98.4	85	3	M5x12	25	32	
80A	6	6.35	7	8	9	9.52	10	11	12	12.7	14	80	100	85	3	M6x15	23	30	

Please contact us for different motor adapters and input shaft bore.

LC 050

FM

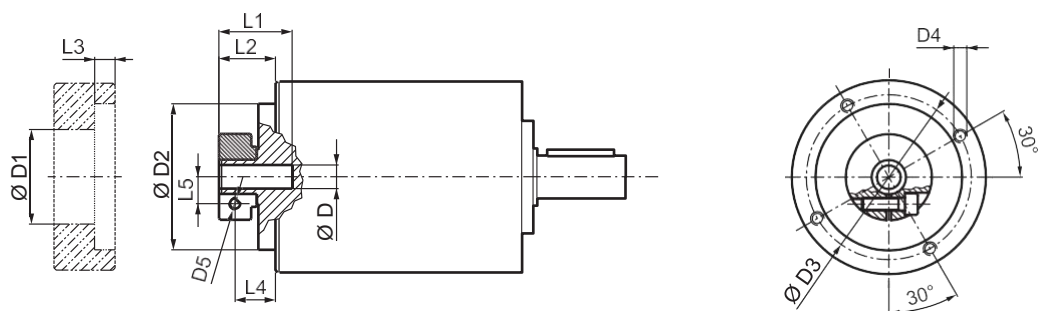

D	D			D1	D2	D3	D4	D5	L1	L2	L3	L4	L5
	6	8	11										
6	6.35	7		32.5	50	42.5	M4x8	M4	21.7	13.2	3	8.2	8
8	9	9.52	10	32.5	50	42.5	M4x8	M4	21.7	13.2	3	8.2	9
11	12	12.7		35.5	50	42.5	M4x8	M4	22	13.5	3	8.5	11
14				35.5	50	42.5	M4x8	M4	25	17	3	10.2	11.5

i	M _{n 2} [Nm]	M _{a 2} [Nm]	M _{p 2} [Nm]	n ₁ [min ⁻¹]	n _{1 max} [min ⁻¹]	ϕ _S [arcmin]	ϕ _R [arcmin]	C _t $\frac{Nm}{arcmin}$	R _{2 max} [N]	A _{2 max} [N]	η %	J _G [kgcm ²]	
												D	D
LC 050 1_3	10	16	28	3300	4000	12'	6'	0.9	500	600	97	6 ... 9.52	10 ... 14
LC 050 1_4	12	20	30	3500	5000	12'	6'	0.9	500	600	97	0.06	0.08
LC 050 1_5	12	20	30	3500	5000	12'	6'	0.9	500	600	97	0.05	0.07
LC 050 1_7	12	20	30	4000	5000	12'	6'	0.9	500	600	97	0.04	0.06
LC 050 1_9	10	16	28	4000	6000	12'	6'	0.9	500	600	97	0.04	0.06
LC 050 2_12	12	20	30	3300	4000	15'	8'	0.75	500	600	94	0.07	0.09
LC 050 2_15	12	20	30	3300	4000	15'	8'	0.75	500	600	94	0.07	0.09
LC 050 2_16	12	20	30	3500	5000	15'	8'	0.75	500	600	94	0.05	0.07
LC 050 2_20	12	20	30	3500	5000	15'	8'	0.75	500	600	94	0.05	0.07
LC 050 2_25	12	20	30	3500	5000	15'	8'	0.75	500	600	94	0.05	0.07
LC 050 2_28	12	20	30	4000	5000	15'	8'	0.75	500	600	94	0.04	0.06
LC 050 2_35	12	20	30	4000	5000	15'	8'	0.75	500	600	94	0.04	0.06
LC 050 2_36	12	20	30	4000	6000	15'	8'	0.75	500	600	94	0.04	0.06
LC 050 2_45	12	20	30	4000	6000	15'	8'	0.75	500	600	94	0.04	0.06
LC 050 2_81	10	16	28	4000	6000	15'	8'	0.75	500	600	94	0.04	0.06

LC

LC 070

25AH ... 80A

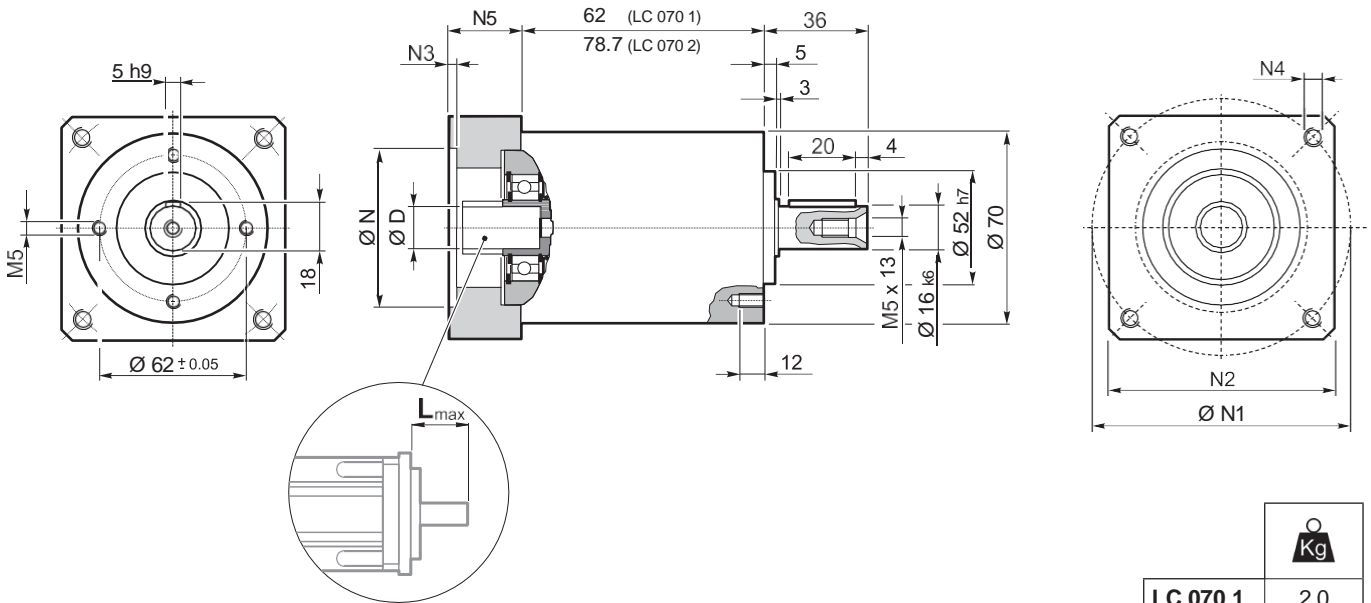

LC 070 1	2.0
LC 070 2	2.3

											N	N1		N2	N3	N4	N5	L _{max}
												min	max					
25AH	6.35	7	8	9	9.52	-	-	-	-	-	25	39	56	65	3.5	4.5	25	25
26AH	6.35	7	8	9	9.52	-	-	-	-	-	26	39	56					
28AH	6.35	7	8	9	9.52	-	-	-	-	-	28	39	56					
30AH	6.35	7	8	9	9.52	-	-	-	-	-	30	39	56					
32AH	6.35	7	8	9	9.52	-	-	-	-	-	32	39	56					
34AH	6.35	7	8	9	9.52	-	-	-	-	-	34	40	56					
36AH	6.35	7	8	9	9.52	-	-	-	-	-	36	42	56					
39AH	6.35	7	8	9	9.52	-	-	-	-	-	39	45	56					
40AH	6.35	7	8	9	9.52	-	-	-	-	-	40	46	56					
38B	6.35	7	8	9	9.52	10	11	12	12.7	-	38.1	66.6	60					
40B	6.35	7	8	9	9.52	10	11	12	12.7	-	40	63	60	3	M4x10	18	25	
50A	6.35	7	8	9	9.52	10	11	12	12.7	-	50	60	60	3	M4x10	18	25	
50B	6.35	7	8	9	9.52	10	11	12	12.7	14	50	65	60	3	M5x12	23	30	
50BH	6.35	7	8	9	9.52	10	11	12	12.7	14	50	65	65	3	5.5	25	32	
50C	6.35	7	8	9	9.52	10	11	12	12.7	14	50	70	60	3	M4x10	23	30	
55MH	6.35	7	8	9	9.52	10	11	12	12.7	-	55	80	65	2	5.5	16	23	
60A	6.35	7	8	9	9.52	10	11	12	12.7	-	60	75	65	3	M5x12	18	25	
60A1	6.35	7	8	9	9.52	10	11	12	12.7	14	60	75	65	3	M5x12	23	30	
60B	6.35	7	8	9	9.52	10	11	12	12.7	14	60	85	75	3	M5x12	23	30	
60C	6.35	7	8	9	9.52	10	11	12	12.7	14	60	90	75	3	M5x12	23	30	
70A	6.35	7	8	9	9.52	10	11	12	12.7	14	70	85	75	3	M6x15	23	30	
70B	6.35	7	8	9	9.52	10	11	12	12.7	14	70	90	75	5	M5x12	23	30	
73A	6.35	7	8	9	9.52	10	11	12	12.7	14	73	98.4	85	3	M5x12	25	32	
80A	6.35	7	8	9	9.52	10	11	12	12.7	14	80	100	85	3	M6x15	23	30	

Please contact us for different motor adapters and input shaft bore.

LC 070

FM

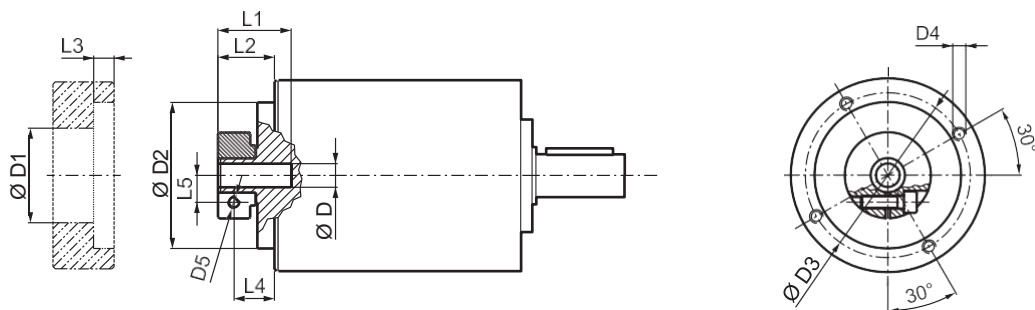

				D1	D2	D3	D4	D5	L1	L2	L3	L4	L5
6.35	7			32.5	50	42.5	M4x8	M4	21.7	13.2	3	8.2	8
8	9	9.52	10	32.5	50	42.5	M4x8	M4	21.7	13.2	3	8.2	9
11	12	12.7		35.5	50	42.5	M4x8	M4	22	13.5	3	8.5	11
14				35.5	50	42.5	M4x8	M4	25	17	3	10.2	11.5

	M _{n2} [Nm]	M _{a2} [Nm]	M _{p2} [Nm]	n ₁ [min ⁻¹]	n _{1 max} [min ⁻¹]	φ _S / φ _R [arcmin]		C _t Nm / arcmin	R _{2 max} [N]	A _{2 max} [N]	η %	J _G [kgcm ²]	
						φ _S	φ _R					6.35 ... 9.52	10 ... 14
LC 070 1_3	18	30	60	3300	4000	12'	6'	3	1300	1400	97	0.12	0.14
LC 070 1_4	25	35	70	3500	5000	12'	6'	3	1300	1400	97	0.08	0.10
LC 070 1_5	25	35	70	3500	5000	12'	6'	3	1300	1400	97	0.06	0.09
LC 070 1_7	25	35	70	4000	5000	12'	6'	3	1300	1400	97	0.05	0.07
LC 070 1_10	18	30	60	4000	6000	12'	6'	3	1300	1400	97	0.04	0.06
LC 070 2_9	18	30	60	3300	4000	15'	8'	2.5	1300	1400	94	0.11	0.13
LC 070 2_12	25	35	70	3300	4000	15'	8'	2.5	1300	1400	94	0.10	0.13
LC 070 2_15	25	35	70	3300	4000	15'	8'	2.5	1300	1400	94	0.10	0.12
LC 070 2_16	25	35	70	3500	5000	15'	8'	2.5	1300	1400	94	0.07	0.09
LC 070 2_20	25	35	70	3500	5000	15'	8'	2.5	1300	1400	94	0.06	0.08
LC 070 2_25	25	35	70	3500	5000	15'	8'	2.5	1300	1400	94	0.06	0.08
LC 070 2_28	25	35	70	4000	5000	15'	8'	2.5	1300	1400	94	0.05	0.07
LC 070 2_30	18	30	60	4000	6000	15'	8'	2.5	1300	1400	94	0.04	0.06
LC 070 2_35	25	35	70	4000	5000	15'	8'	2.5	1300	1400	94	0.05	0.07
LC 070 2_40	25	35	70	4000	6000	15'	8'	2.5	1300	1400	94	0.04	0.06
LC 070 2_50	25	35	70	4000	6000	15'	8'	2.5	1300	1400	94	0.04	0.06
LC 070 2_70	25	35	70	4000	6000	15'	8'	2.5	1300	1400	94	0.04	0.06
LC 070 2_100	18	30	60	4000	6000	15'	8'	2.5	1300	1400	94	0.04	0.06

LC

LC 090

40B1 ... 110B1

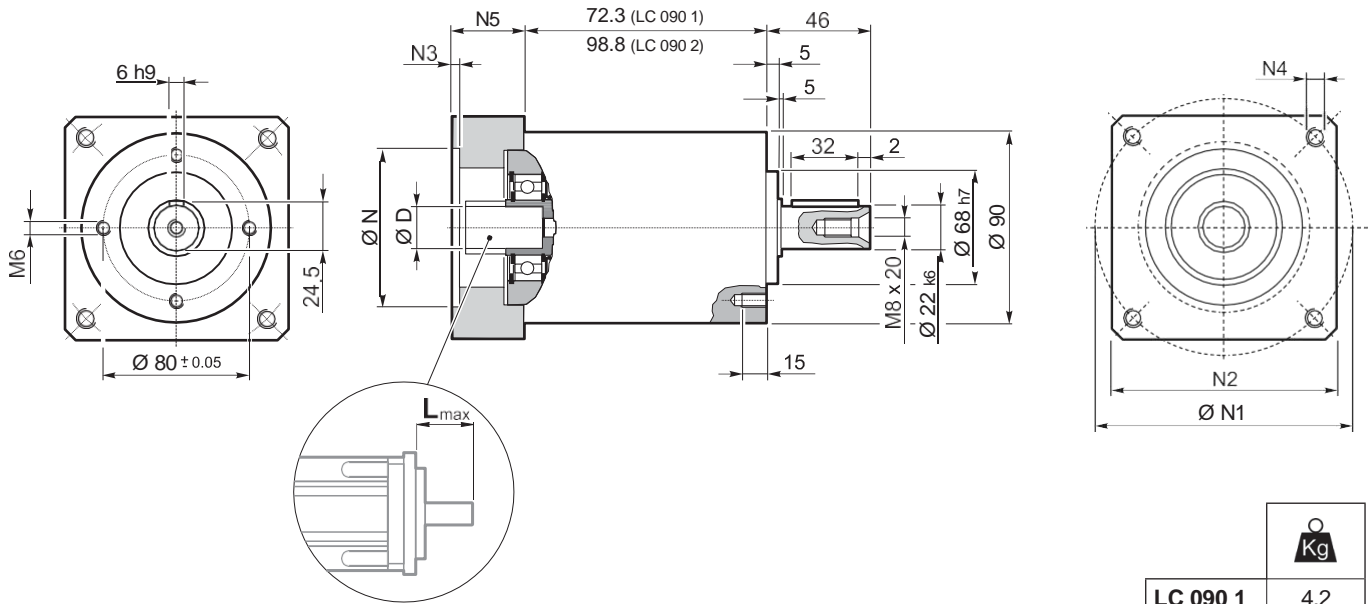

LC 090 1	4.2
LC 090 2	5.3

												N	N1	N2	N3	N4	N5	L _{max}
40B1	9	9.52	11	12	12.7	14	-	-	-	-	-	40	63	80	4	M4x10	34	40
45A	9	9.52	11	12	12.7	-	-	-	-	-	-	45	63	80	4	M4x10	34	40
50B1	9	9.52	11	12	12.7	14	-	-	-	-	-	50	65	80	4	M5x16	34	40
50BH1	9	9.52	11	12	12.7	14	-	-	-	-	-	50	65	80	4	5.5	34	40
50C1	9	9.52	11	12	12.7	14	-	-	-	-	-	50	70	80	4	M4x10	34	40
50D	9	9.52	11	12	12.7	14	-	-	-	-	-	50	95	80	4	M6x10	34	40
55A	9	9.52	11	12	12.7	14	15.875	16	17	19	19.05	55.5	125.7	105	4	M6x16	34	40
60A2	9	9.52	11	12	12.7	14	-	-	-	-	-	60	75	80	4	M5x16	34	40
60AH2	9	9.52	11	12	12.7	14	-	-	-	-	-	60	75	90	4	5.5	34	40
60B1	9	9.52	11	12	12.7	14	15.875	16	-	-	-	60	85	80	4	M5x16	34	40
60C1	9	9.52	11	12	12.7	14	15.875	16	-	-	-	60	90	80	4	M5x16	34	40
70A1	9	9.52	11	12	12.7	14	15.875	16	17	19	19.05	70	85	80	4	M6x20	34	40
70AH1	9	9.52	11	12	12.7	14	15.875	16	17	19	19.05	70	85	90	4	6.5	34	40
70B1	9	9.52	11	12	12.7	14	15.875	16	17	19	19.05	70	90	80	4	M5x16	34	40
73A1	9	9.52	11	12	12.7	14	-	-	-	-	-	73	98.4	85	4	M5x16	34	40
80A1	9	9.52	11	12	12.7	14	15.875	16	17	19	19.05	80	100	90	4	M6x16	34	40
95A	9	9.52	11	12	12.7	14	15.875	16	17	19	19.05	95	115	100	4	M8x20	34	40
95B	9	9.52	11	12	12.7	14	15.875	16	17	19	19.05	95	130	115	4	M8x20	34	40
110A	9	9.52	11	12	12.7	14	15.875	16	17	19	19.05	110	130	115	4	M8x20	34	40
110B	9	9.52	11	12	12.7	14	15.875	16	17	19	19.05	110	145	120	6.5	M8x20	44	50
110B1	9	9.52	11	12	12.7	14	15.875	16	17	19	19.05	110	145	120	6.5	M8x20	54	60

Please contact us for different motor adapters and input shaft bore.

LC 090

FM

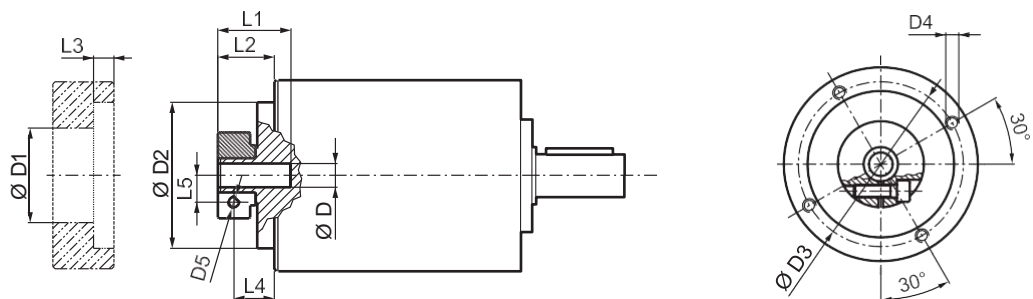

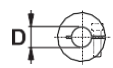
				D1	D2	D3	D4	D5	L1	L2	L3	L4	L5
9	9.52			38	68	76.5	M6x10	M6	34	26.8	9.5	18.8	10.5
11	12	12.7		43	68	76.5	M6x10	M6	34	26.8	9.5	18.8	12.5
14	15.875	16	17	48	68	76.5	M6x10	M6	34	26.8	9.5	18.8	14.5
19	19.05			51	68	76.5	M6x10	M6	34	26.8	9.5	18.8	16.5

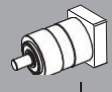
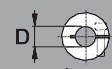
	M_{n2} [Nm]	M_{a2} [Nm]	M_{p2} [Nm]	n_1 [min ⁻¹]	n_{1max} [min ⁻¹]	ϕ_S [arcmin]	ϕ_R [arcmin]	C_t $\frac{Nm}{arcmin}$	R_{2max} [N]	A_{2max} [N]	η %	J_G [kgcm ²]	
													9 ... 12.7
LC 090 1_3	37	70	150	2900	3500	12'	6'	9	2200	1900	97	0.62	0.77
LC 090 1_4	43	80	160	3100	4500	12'	6'	9	2200	1900	97	0.41	0.55
LC 090 1_5	43	80	160	3200	4500	12'	6'	9	2200	1900	97	0.33	0.47
LC 090 1_7	43	80	160	4000	4500	12'	6'	9	2200	1900	97	0.26	0.40
LC 090 1_10	37	70	150	4000	6000	12'	6'	9	2200	1900	97	0.21	0.35
LC 090 2_9	37	70	150	2900	3500	15'	8'	8.5	2200	1900	94	0.47	0.61
LC 090 2_12	43	80	160	2900	3500	15'	8'	8.5	2200	1900	94	0.44	0.58
LC 090 2_15	43	80	160	2900	3500	15'	8'	8.5	2200	1900	94	0.43	0.57
LC 090 2_16	43	80	160	3100	4500	15'	8'	8.5	2200	1900	94	0.31	0.45
LC 090 2_20	43	80	160	3200	4500	15'	8'	8.5	2200	1900	94	0.26	0.40
LC 090 2_25	43	80	160	3200	4500	15'	8'	8.5	2200	1900	94	0.26	0.40
LC 090 2_28	43	80	160	4000	4500	15'	8'	8.5	2200	1900	94	0.22	0.36
LC 090 2_30	37	70	150	4000	6000	15'	8'	8.5	2200	1900	94	0.20	0.34
LC 090 2_35	43	80	160	4000	4500	15'	8'	8.5	2200	1900	94	0.22	0.36
LC 090 2_40	43	80	160	4000	6000	15'	8'	8.5	2200	1900	94	0.20	0.34
LC 090 2_50	43	80	160	4000	6000	15'	8'	8.5	2200	1900	94	0.20	0.34
LC 090 2_70	43	80	160	4000	6000	15'	8'	8.5	2200	1900	94	0.20	0.34
LC 090 2_100	37	70	150	4000	6000	15'	8'	8.5	2200	1900	94	0.19	0.34

LC

LC 120

50D ... 130A1

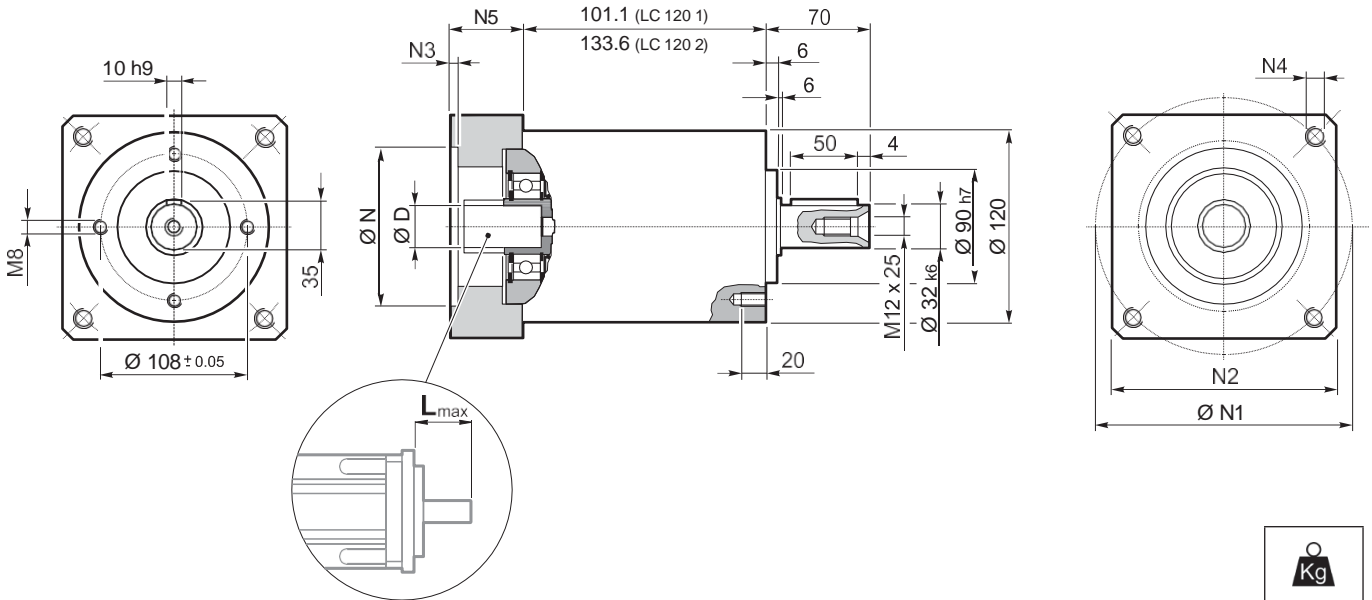

LC 120 1	9.6
LC 120 2	12.1

										N	N1	N2	N3	N4	N5	L _{max}
	14	15	15.875	16	19	-	-	-	-							
50D	14	15	15.875	16	19	-	-	-	-	50	95	100	5	M6x14	28	40
55A	14	15	15.875	16	19	-	-	-	-	55.5	125.7	105	5	M6x16	28	40
60A2	14	15	15.875	16	19	-	-	-	-	60	75	100	5	M5x14	28	40
60AH2	14	15	15.875	16	19	-	-	-	-	60	75	100	5	6.5	33	40
60B1	14	15	15.875	16	19	-	-	-	-	60	85	100	6.5	M5x14	28	40
70A1	14	15	15.875	16	19	-	-	-	-	70	85	100	5	M6x14	28	40
70AH1	14	15	15.875	16	19	-	-	-	-	70	85	100	5	6	33	40
70B1	14	15	15.875	16	19	-	-	-	-	70	90	100	6.5	M5x12	28	40
80A1	14	15	15.875	16	19	-	-	-	-	80	100	100	5	M6x16	28	40
80AH1	14	15	15.875	16	19	-	-	-	-	80	100	100	5	6.5	28	40
95A	14	15	15.875	16	19	-	-	-	-	95	115	100	5	M8x18	28	40
95A1	14	15	15.875	16	19	22	24	-	-	95	115	100	5	M8x18	38	50
95B	14	15	15.875	16	19	-	-	-	-	95	130	115	5	M8x18	28	40
110A	14	15	15.875	16	19	-	-	-	-	110	130	115	5	M8x18	28	40
110A1	14	15	15.875	16	19	22	24	-	-	110	130	115	6.5	M8x20	38	50
110B	14	15	15.875	16	19	22	24	-	-	110	145	120	6.5	M8x20	38	50
110B1	14	15	15.875	16	19	22	24	28	-	110	145	120	6.5	M8x20	48	60
130A	14	15	15.875	16	19	22	24	-	-	130	165	140	6.5	M10x20	38	50
130A1	14	15	15.875	16	19	22	24	28	32	130	165	140	6.5	M10x25	48	60

Please contact us for different motor adapters and input shaft bore.

LC 120

FM

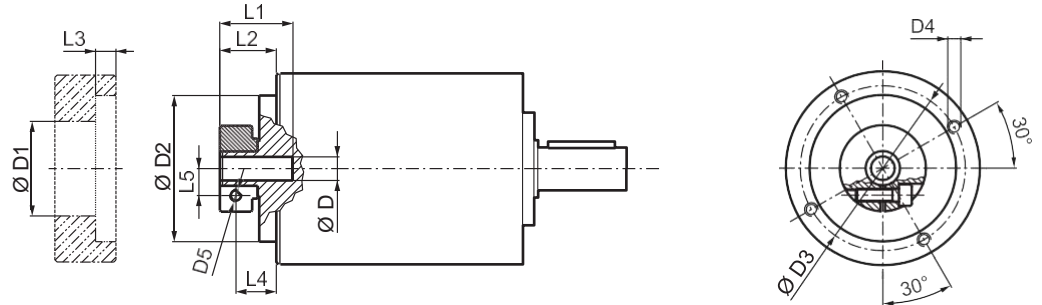

				D1	D2	D3	D4	D5	L1	L2	L3	L4	L5
14	15	15.875	16	48	90	98	M6x15	M6	33.5	20	7.6	12.5	14.5
19				51	90	98	M6x15	M6	33.5	20	7.6	12.5	16.5
22	24			56.5	90	98	M6x15	M6	36.5	23	7.6	14	19
28				67	90	98	M6x15	M8	36.5	23	7.6	14	22.5
32				71	90	98	M6x15	M8	38	24.5	7.6	15.5	24.5

	M_{n2} [Nm]	M_{a2} [Nm]	M_{p2} [Nm]	n_1 [min ⁻¹]	$n_{1\max}$ [min ⁻¹]	ϕ_S [arcmin]	ϕ_R [arcmin]	C_t $\frac{Nm}{arcmin}$	$R_{2\max}$ [N]	$A_{2\max}$ [N]	η %	J_G [kgcm ²]		
													14 ... 19	22 ; 24
LC 120 1_3	95	160	300	2500	3500	12'	6'	25	3500	3000	97	2.17	2.77	3.13
LC 120 1_4	110	190	360	2800	4500	12'	6'	25	3500	3000	97	1.30	1.89	2.26
LC 120 1_5	110	190	360	3000	4500	12'	6'	25	3500	3000	97	0.96	1.56	1.92
LC 120 1_7	110	190	360	3500	4500	12'	6'	25	3500	3000	97	0.66	1.26	1.62
LC 120 1_10	95	160	300	3500	5000	12'	6'	25	3500	3000	97	0.49	1.09	1.45
LC 120 2_9	95	160	300	2500	3500	15'	8'	22.5	3500	3000	94	1.61	2.20	2.57
LC 120 2_12	110	190	360	2500	3500	15'	8'	22.5	3500	3000	94	1.51	2.10	2.47
LC 120 2_15	110	190	360	2500	3500	15'	8'	22.5	3500	3000	94	1.47	2.06	2.43
LC 120 2_16	110	190	360	2800	4500	15'	8'	22.5	3500	3000	94	0.92	1.52	1.88
LC 120 2_20	110	190	360	3000	4500	15'	8'	22.5	3500	3000	94	0.90	1.50	1.86
LC 120 2_25	110	190	360	3000	4500	15'	8'	22.5	3500	3000	94	0.71	1.30	1.67
LC 120 2_28	110	190	360	3500	4500	15'	8'	22.5	3500	3000	94	0.54	1.13	1.50
LC 120 2_30	95	160	300	3500	5000	15'	8'	22.5	3500	3000	94	0.44	1.04	1.40
LC 120 2_35	110	190	360	3500	4500	15'	8'	22.5	3500	3000	94	0.53	1.13	1.49
LC 120 2_40	110	190	360	3500	5000	15'	8'	22.5	3500	3000	94	0.43	1.03	1.39
LC 120 2_50	110	190	360	3500	5000	15'	8'	22.5	3500	3000	94	0.43	1.02	1.39
LC 120 2_70	110	190	360	3500	5000	15'	8'	22.5	3500	3000	94	0.42	1.02	1.38
LC 120 2_100	95	160	300	3500	5000	15'	8'	22.5	3500	3000	94	0.42	1.02	1.38

LC

LC 155

55A1 ... 180A1

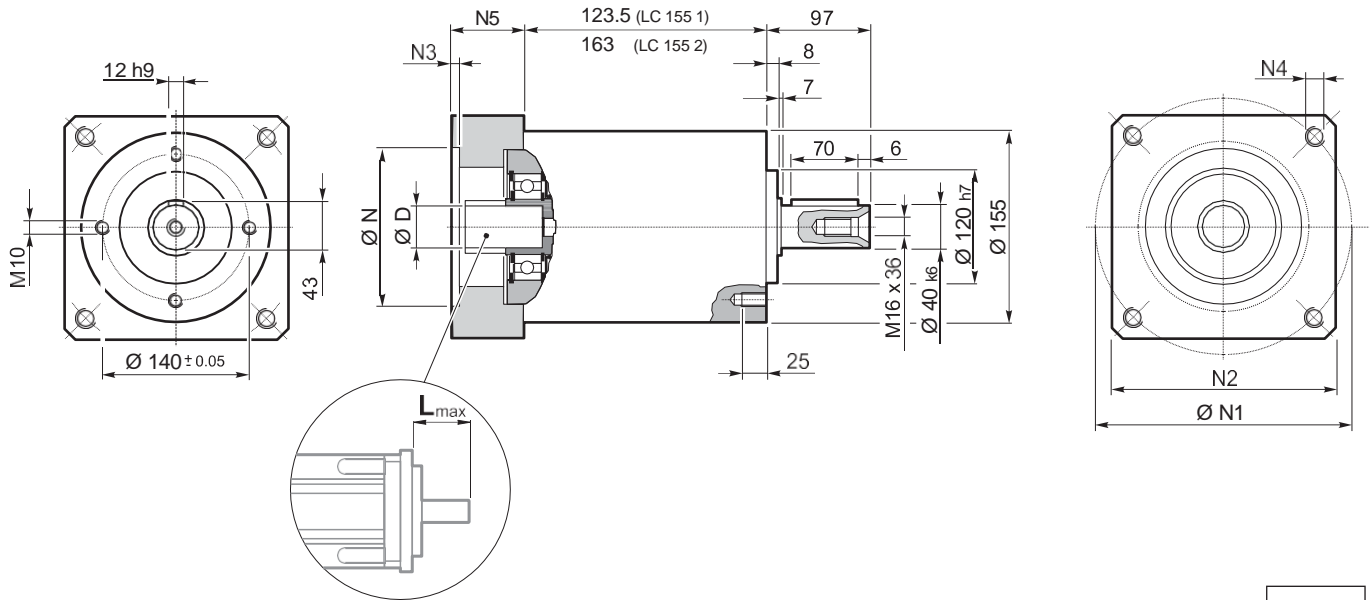

LC 155 1	19.3
LC 155 2	24.3

								N	N1	N2	N3	N4	N5	L _{max}
	D													
55A1	19	-	-	-	-	-	-	55.5	125.7	130	4	M6x15	39.5	50
80A2	19	-	-	-	-	-	-	80	100	130	4	M6x15	39.5	50
95A1	19	22	24	-	-	-	-	95	115	130	4	M8x20	39.5	50
110A1	19	22	24	-	-	-	-	110	130	130	4	M8x20	39.5	50
110B1	19	22	24	-	-	-	-	110	145	130	6.5	M8x20	49.5	60
114A	19	22	24	28	32	35	38	114.3	200	170	5.5	M12x25	69.5	80
130A	19	22	24	-	-	-	-	130	165	140	4	M10x20	39.5	50
130A1	19	22	24	28	32	-	-	130	165	140	4	M10x20	49.5	60
180A	19	22	24	28	32	-	-	180	215	190	5.5	M14x25	49.5	60
180A1	19	22	24	28	32	35	38	180	215	190	5.5	M14x25	69.5	80



Please contact us for different motor adapters and input shaft bore.

LC 155

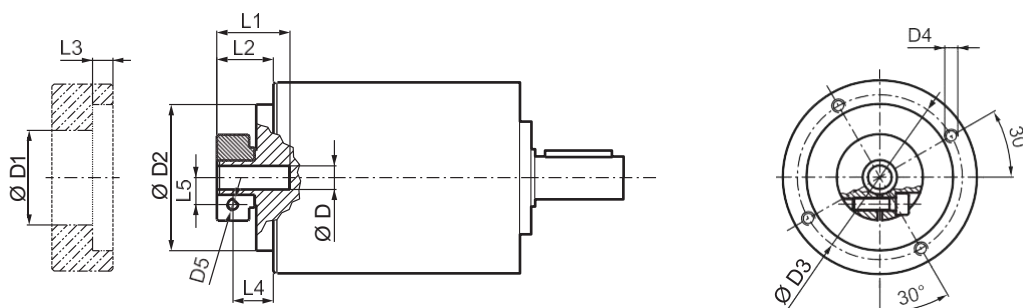
FM

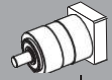

	D1	D2	D3	D4	D5	L1	L2	L3	L4	L5
19	51	113	125.5	M8x15	M6	40	27.5	6	20	16.5
22 24	56.5	113	125.5	M8x15	M6	41	28.5	6	19.5	19
28	67	113	125.5	M8x15	M8	41	28.5	6	19.5	22.5
32	71	113	125.5	M8x15	M8	41	28.5	6	18.5	24.5
35	73	113	125.5	M8x15	M8	50	37.5	11.25	26	26
38	77.5	113	125.5	M8x15	M8	50	37.5	11.25	26	28

	M_{n2}	M_{a2}	M_{p2}	n_1	$n_{1 \max}$	ϕ_s	ϕ_R	C_t	$R_{2 \max}$	$A_{2 \max}$	η	J_G [kgcm ²]			
												D 	19	22 ; 24	28 ; 32
LC 155 1 _ 3	[Nm]	[Nm]	[Nm]	[min ⁻¹]	[min ⁻¹]	[arcmin]		$\frac{Nm}{arcmin}$	[N]	[N]	%				
LC 155 1 _ 4	250	380	600	2100	3600	12'	6'	43	6000	5000	97	7.99	8.19	8.54	9.90
LC 155 1 _ 5	300	450	700	2400	3600	12'	6'	43	6000	5000	97	4.66	4.87	5.23	6.57
LC 155 1 _ 7	300	450	900	2900	3600	12'	6'	43	6000	5000	97	3.32	3.53	3.88	5.23
LC 155 1 _ 10	300	450	900	3200	3600	12'	6'	43	6000	5000	97	2.14	2.35	2.70	4.05
LC 155 2 _ 9	230	350	750	3200	3600	12'	6'	43	6000	5000	97	1.45	1.66	2.01	3.36
LC 155 2 _ 12	250	380	600	2100	3600	15'	8'	37.5	6000	5000	94	5.30	5.51	5.86	7.21
LC 155 2 _ 15	300	450	700	2100	3600	15'	8'	37.5	6000	5000	94	4.93	5.14	5.49	6.84
LC 155 2 _ 16	300	450	900	2100	3600	15'	8'	37.5	6000	5000	94	4.79	4.99	5.34	6.70
LC 155 2 _ 20	300	450	700	2400	3600	15'	8'	37.5	6000	5000	94	2.97	3.18	3.53	4.88
LC 155 2 _ 25	300	450	900	2900	3600	15'	8'	37.5	6000	5000	94	2.23	2.44	2.79	4.14
LC 155 2 _ 28	300	450	900	2900	3600	15'	8'	37.5	6000	5000	94	2.18	2.39	2.74	4.09
LC 155 2 _ 30	300	450	900	3200	3600	15'	8'	37.5	6000	5000	94	1.58	1.79	2.14	3.49
LC 155 2 _ 35	250	380	600	3200	3600	15'	8'	37.5	6000	5000	94	1.23	1.44	1.79	3.14
LC 155 2 _ 40	300	450	900	3200	3600	15'	8'	37.5	6000	5000	94	1.55	1.76	2.11	3.46
LC 155 2 _ 50	300	450	700	3200	3600	15'	8'	37.5	6000	5000	94	1.20	1.41	1.76	3.11
LC 155 2 _ 70	300	450	900	3200	3600	15'	8'	37.5	6000	5000	94	1.19	1.39	1.74	3.10
LC 155 2 _ 100	300	450	900	3200	3600	15'	8'	37.5	6000	5000	94	1.17	1.38	1.73	3.08
LC 155 2 _ 100	230	350	750	3200	3600	15'	8'	37.5	6000	5000	94	1.17	1.38	1.73	3.08

LC

LC 070P

25AH ... 80A

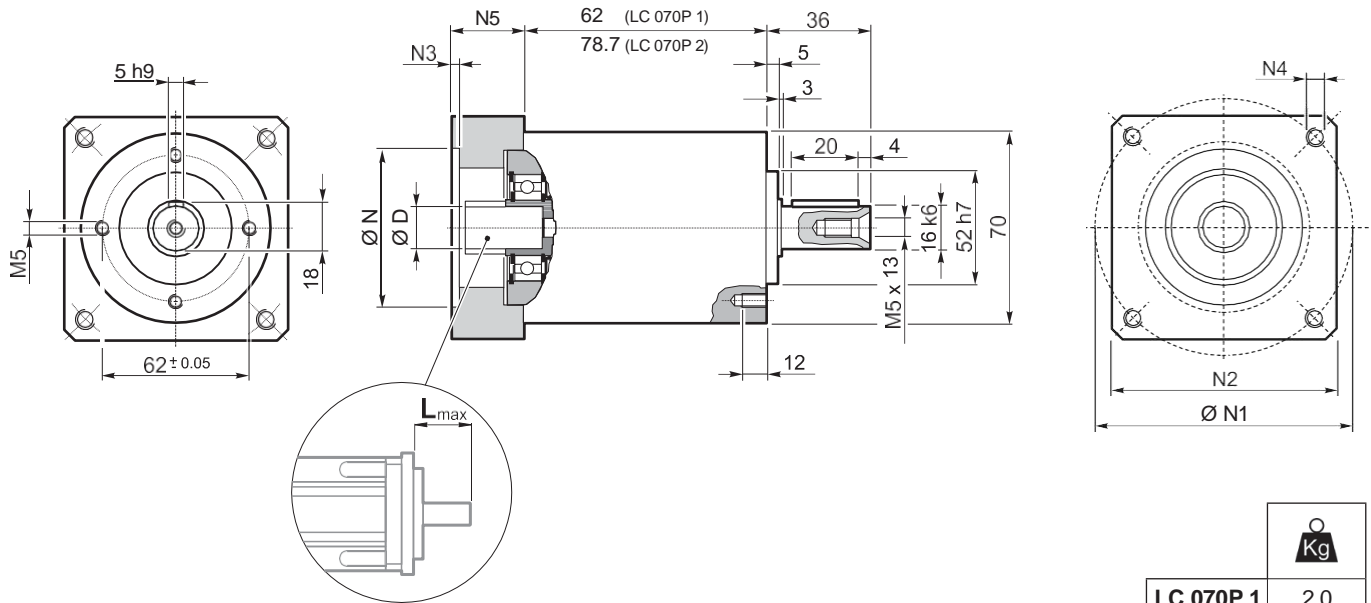

LC 070P 1	2.0
LC 070P 2	2.3

											N	N1		N2	N3	N4	N5	L _{max}
												min	max					
25AH	6.35	7	8	9	9.52	-	-	-	-	-	25	39	56	65	3.5	4.5	25	25
26AH	6.35	7	8	9	9.52	-	-	-	-	-	26	39	56					
28AH	6.35	7	8	9	9.52	-	-	-	-	-	28	39	56					
30AH	6.35	7	8	9	9.52	-	-	-	-	-	30	39	56					
32AH	6.35	7	8	9	9.52	-	-	-	-	-	32	39	56					
34AH	6.35	7	8	9	9.52	-	-	-	-	-	34	40	56					
36AH	6.35	7	8	9	9.52	-	-	-	-	-	36	42	56					
39AH	6.35	7	8	9	9.52	-	-	-	-	-	39	45	56					
40AH	6.35	7	8	9	9.52	-	-	-	-	-	40	46	56					
38B	6.35	7	8	9	9.52	10	11	12	12.7	-	38.1	66.6	60	3	M4x10	18	25	
40B	6.35	7	8	9	9.52	10	11	12	12.7	-	40	63	60	3	M4x10	18	25	
50A	6.35	7	8	9	9.52	10	11	12	12.7	-	50	60	60	3	M4x10	18	25	
50B	6.35	7	8	9	9.52	10	11	12	12.7	14	50	65	60	3	M5x12	23	30	
50BH	6.35	7	8	9	9.52	10	11	12	12.7	14	50	65	65	3	5.5	25	32	
50C	6.35	7	8	9	9.52	10	11	12	12.7	14	50	70	60	3	M4x10	23	30	
55MH	6.35	7	8	9	9.52	10	11	12	12.7	-	55	80	65	2	5.5	16	23	
60A	6.35	7	8	9	9.52	10	11	12	12.7	-	60	75	65	3	M5x12	18	25	
60A1	6.35	7	8	9	9.52	10	11	12	12.7	14	60	75	65	3	M5x12	23	30	
60B	6.35	7	8	9	9.52	10	11	12	12.7	14	60	85	75	3	M5x12	23	30	
60C	6.35	7	8	9	9.52	10	11	12	12.7	14	60	90	75	3	M5x12	23	30	
70A	6.35	7	8	9	9.52	10	11	12	12.7	14	70	85	75	3	M6x15	23	30	
70B	6.35	7	8	9	9.52	10	11	12	12.7	14	70	90	75	5	M5x12	23	30	
73A	6.35	7	8	9	9.52	10	11	12	12.7	14	73	98.4	85	3	M5x12	25	32	
80A	6.35	7	8	9	9.52	10	11	12	12.7	14	80	100	85	3	M6x15	23	30	

Please contact us for different motor adapters and input shaft bore.

LC 070P

FM

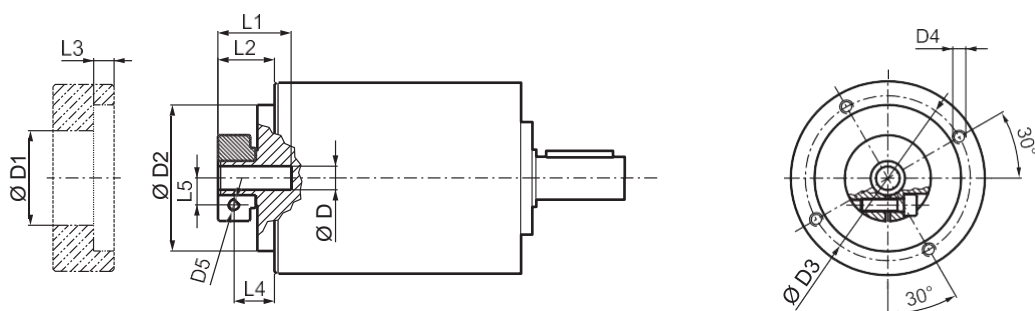

D				D1	D2	D3	D4	D5	L1	L2	L3	L4	L5
6.35	7			32.5	50	42.5	M4x8	M4	21.7	13.2	3	8.2	8
8	9	9.52	10	32.5	50	42.5	M4x8	M4	21.7	13.2	3	8.2	9
11	12	12.7		35.5	50	42.5	M4x8	M4	22	13.5	3	8.5	11
14				35.5	50	42.5	M4x8	M4	25	17	3	10.2	11.5

 i	M _{n2}	M _{a2}	M _{p2}	n ₁	n _{1 max}	φ _S	φ _R	C _t	R _{2 max}	A _{2 max}	η	J _G [kgcm ²]	
	[Nm]	[Nm]	[Nm]	[min ⁻¹]	[min ⁻¹]	[arcmin]	[arcmin]	$\frac{Nm}{arcmin}$	[N]	[N]	%	6 ... 9.52	11 ... 14
LC 070P 1_3	29	55	60	3300	4000	12'	6'	3	1300	1400	97	0.12	0.14
LC 070P 1_4	30	45	70	3500	5000	12'	6'	3	1300	1400	97	0.08	0.10
LC 070P 1_5	28	40	70	3500	5000	12'	6'	3	1300	1400	97	0.06	0.09
LC 070P 1_7	28	40	70	4000	5000	12'	6'	3	1300	1400	97	0.05	0.07
LC 070P 1_10	20	33	60	4000	6000	12'	6'	3	3500	1400	97	0.04	0.06
LC 070P 2_9	29	55	60	3300	4000	15'	8'	2.5	1300	1400	94	0.11	0.13
LC 070P 2_12	29	55	70	3300	4000	15'	8'	2.5	1300	1400	94	0.10	0.13
LC 070P 2_15	29	55	70	3300	4000	15'	8'	2.5	1300	1400	94	0.10	0.12
LC 070P 2_16	30	45	70	3500	5000	15'	8'	2.5	1300	1400	94	0.07	0.09
LC 070P 2_20	30	45	70	3500	5000	15'	8'	2.5	1300	1400	94	0.06	0.08
LC 070P 2_25	30	45	70	3500	5000	15'	8'	2.5	1300	1400	94	0.06	0.08
LC 070P 2_28	30	45	70	4000	6000	15'	8'	2.5	1300	1400	94	0.05	0.07
LC 070P 2_30	29	55	60	4000	6000	15'	8'	2.5	1300	1400	94	0.04	0.06
LC 070P 2_35	30	45	70	4000	6000	15'	8'	2.5	1300	1400	94	0.05	0.07
LC 070P 2_40	30	45	70	4000	6000	15'	8'	2.5	1300	1400	94	0.04	0.06
LC 070P 2_50	30	45	70	4000	6000	15'	8'	2.5	1300	1400	94	0.04	0.06
LC 070P 2_70	30	45	70	4000	6000	15'	8'	2.5	1300	1400	94	0.04	0.06
LC 070P 2_100	20	33	60	4000	6000	15'	8'	2.5	1300	1400	94	0.04	0.06

LC

LC 090P

40B1 ... 110B1

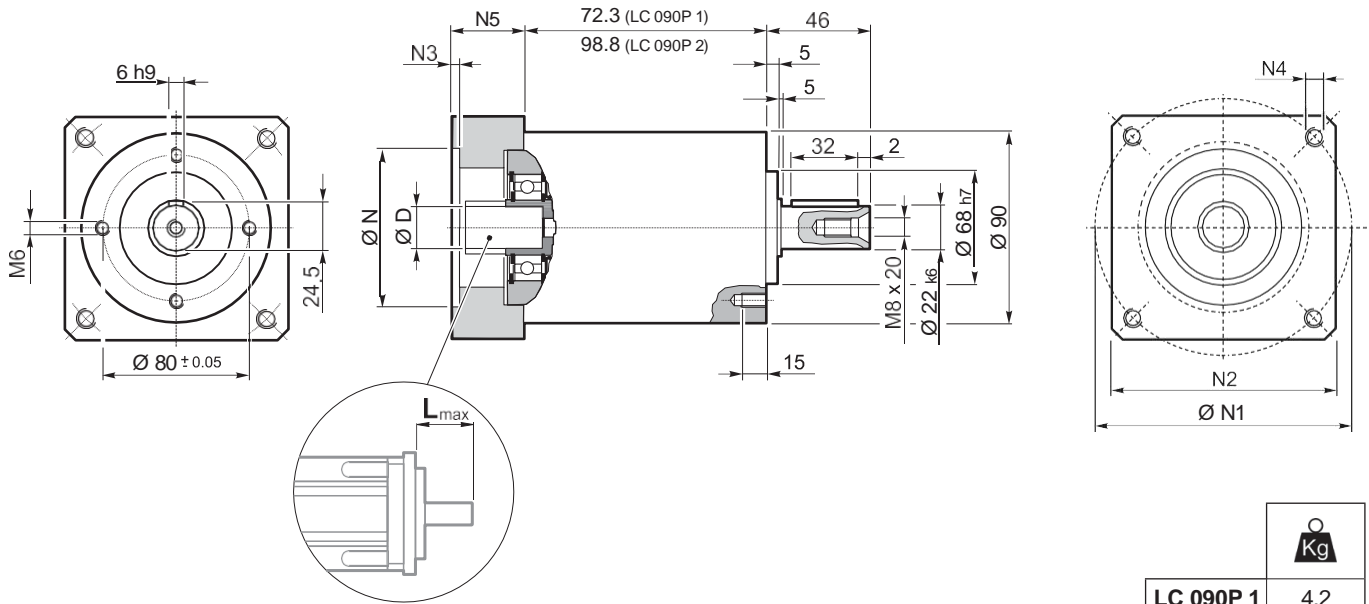

LC 090P 1	4.2
LC 090P 2	5.3

												N	N1	N2	N3	N4	N5	L _{max}
40B1	9	9.52	11	12	12.7	14	-	-	-	-	-	40	63	80	4	M4x10	34	40
45A	9	9.52	11	12	12.7	-	-	-	-	-	-	45	63	80	4	M4x10	34	40
50B1	9	9.52	11	12	12.7	14	-	-	-	-	-	50	65	80	4	M5x16	34	40
50BH1	9	9.52	11	12	12.7	14	-	-	-	-	-	50	65	80	4	5.5	34	40
50C1	9	9.52	11	12	12.7	14	-	-	-	-	-	50	70	80	4	M4x10	34	40
50D	9	9.52	11	12	12.7	14	-	-	-	-	-	50	95	80	4	M6x10	34	40
55A	9	9.52	11	12	12.7	14	15.875	16	17	19	19.05	55.5	125.7	105	4	M6x16	34	40
60A2	9	9.52	11	12	12.7	14	-	-	-	-	-	60	75	80	4	M5x16	34	40
60AH2	9	9.52	11	12	12.7	14	-	-	-	-	-	60	75	90	4	5.5	34	40
60B1	9	9.52	11	12	12.7	14	15.875	16	-	-	-	60	85	80	4	M5x16	34	40
60C1	9	9.52	11	12	12.7	14	15.875	16	-	-	-	60	90	80	4	M5x16	34	40
70A1	9	9.52	11	12	12.7	14	15.875	16	17	19	19.05	70	85	80	4	M6x20	34	40
70AH1	9	9.52	11	12	12.7	14	15.875	16	17	19	19.05	70	85	90	4	6.5	34	40
70B1	9	9.52	11	12	12.7	14	15.875	16	17	19	19.05	70	90	80	4	M5x16	34	40
73A1	9	9.52	11	12	12.7	14	-	-	-	-	-	73	98.4	85	4	M5x16	34	40
80A1	9	9.52	11	12	12.7	14	15.875	16	17	19	19.05	80	100	90	4	M6x16	34	40
95A	9	9.52	11	12	12.7	14	15.875	16	17	19	19.05	95	115	100	4	M8x20	34	40
95B	9	9.52	11	12	12.7	14	15.875	16	17	19	19.05	95	130	115	4	M8x20	34	40
110A	9	9.52	11	12	12.7	14	15.875	16	17	19	19.05	110	130	115	4	M8x20	34	40
110B	9	9.52	11	12	12.7	14	15.875	16	17	19	19.05	110	145	120	6.5	M8x20	44	50
110B1	9	9.52	11	12	12.7	14	15.875	16	17	19	19.05	110	145	120	6.5	M8x20	54	60

Please contact us for different motor adapters and input shaft bore.

LC 090P

FM

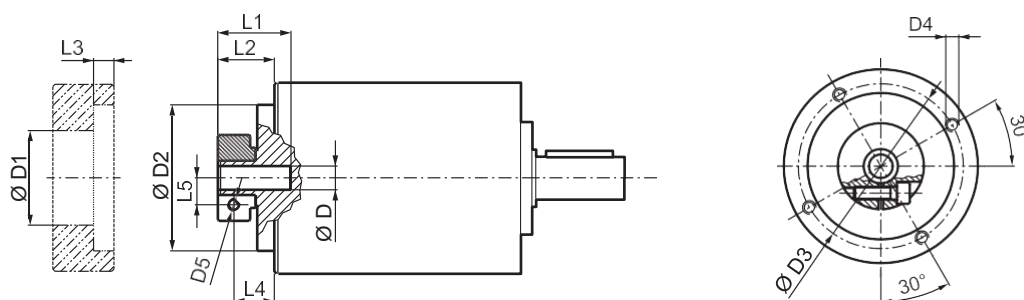

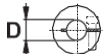
				D1	D2	D3	D4	D5	L1	L2	L3	L4	L5
9	9.52			38	68	76.5	M6x10	M6	34	26.8	9.5	18.8	10.5
11	12	12.7		43	68	76.5	M6x10	M6	34	26.8	9.5	18.8	12.5
14	15.875	16	17	48	68	76.5	M6x10	M6	34	26.8	9.5	18.8	14.5
19	19.05			51	68	76.5	M6x10	M6	34	26.8	9.5	18.8	16.5

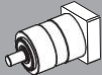
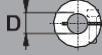
	i	M _{n2}	M _{a2}	M _{p2}	n ₁	n _{1 max}	φ _S	φ _R	C _t	R _{2 max}	A _{2 max}	η	J _G [kgcm ²]	
		[Nm]	[Nm]	[Nm]	[min ⁻¹]	[min ⁻¹]	[arcmin]	[arcmin]	$\frac{Nm}{arcmin}$	[N]	[N]	%	 8 ... 12.7	14 ... 19
LC 090P 1_3		65	120	150	3500	4000	12'	6'	12	2200	1900	97	0.62	0.77
LC 090P 1_4		60	110	160	3500	4000	12'	6'	12	2200	1900	97	0.41	0.55
LC 090P 1_5		50	100	160	3200	4500	12'	6'	9	2200	1900	97	0.33	0.47
LC 090P 1_7		50	100	160	4000	6000	12'	6'	9	2200	1900	97	0.26	0.40
LC 090P 1_10		40	75	150	4000	6000	12'	6'	9	2200	1900	97	0.21	0.35
LC 090P 2_9		65	120	150	3500	4000	15'	8'	12	2200	1900	94	0.47	0.61
LC 090P 2_12		65	120	160	3500	4000	15'	8'	12	2200	1900	94	0.44	0.58
LC 090P 2_15		65	120	160	3500	4000	15'	8'	12	2200	1900	94	0.43	0.57
LC 090P 2_16		60	110	160	3500	4500	15'	8'	12	2200	1900	94	0.31	0.45
LC 090P 2_20		60	110	160	3500	4500	15'	8'	12	2200	1900	94	0.26	0.40
LC 090P 2_25		50	100	160	3200	4500	15'	8'	9	2200	1900	94	0.26	0.40
LC 090P 2_28		50	100	160	4000	6000	15'	8'	9	2200	1900	94	0.22	0.36
LC 090P 2_30		65	120	150	4000	6000	15'	8'	12	2200	1900	94	0.20	0.34
LC 090P 2_35		50	100	160	4000	6000	15'	8'	9	2200	1900	94	0.22	0.36
LC 090P 2_40		60	110	160	4000	6000	15'	8'	12	2200	1900	94	0.20	0.34
LC 090P 2_50		50	100	160	4000	6000	15'	8'	9	2200	1900	94	0.20	0.34
LC 090P 2_70		50	100	160	4000	6000	15'	8'	9	2200	1900	94	0.20	0.34
LC 090P 2_100		40	75	150	4000	6000	15'	8'	9	2200	1900	94	0.19	0.34

LC

LC 120P

50D ... 130A1

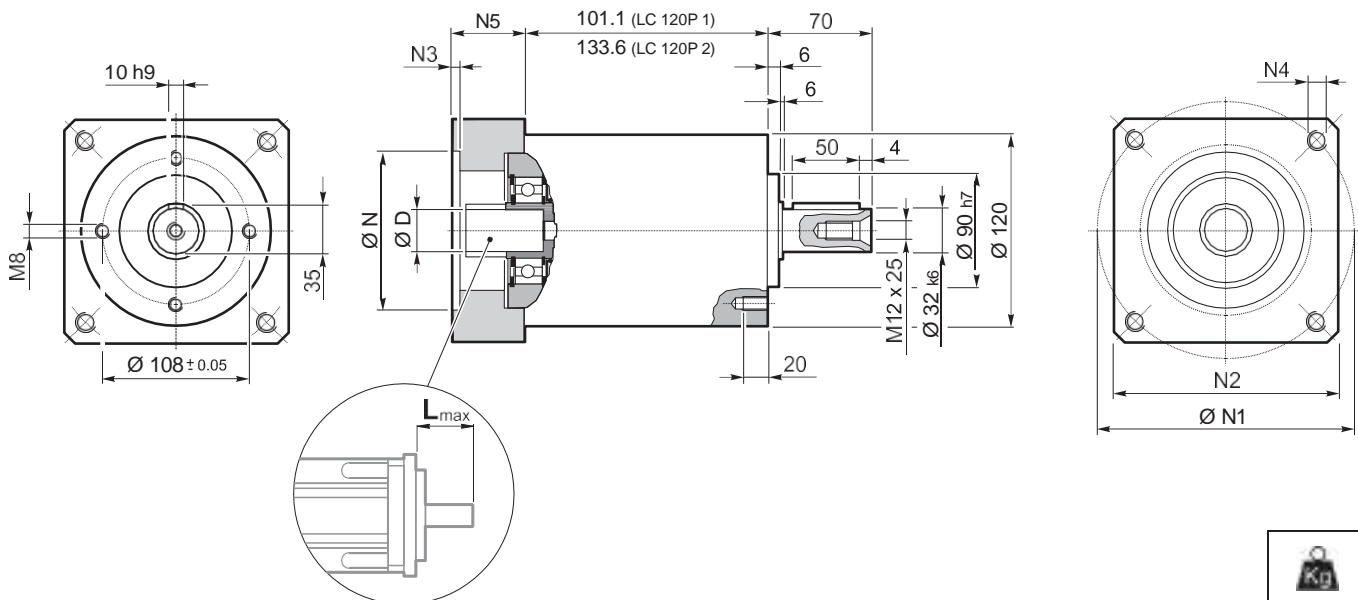

LC 120P 1	9.6
LC 120P 2	12.1

										N	N1	N2	N3	N4	N5	L _{max}
50D	14	15	15.875	16	19	-	-	-	-	50	95	100	5	M6x14	28	40
55A	14	15	15.875	16	19	-	-	-	-	55.5	125.7	105	5	M6x16	28	40
60A2	14	15	15.875	16	19	-	-	-	-	60	75	100	5	M5x14	28	40
60AH2	14	15	15.875	16	19	-	-	-	-	60	75	100	5	6.5	33	40
60B1	14	15	15.875	16	19	-	-	-	-	60	85	100	6.5	M5x14	28	40
70A1	14	15	15.875	16	19	-	-	-	-	70	85	100	5	M6x14	28	40
70AH1	14	15	15.875	16	19	-	-	-	-	70	85	100	5	6	33	40
70B1	14	15	15.875	16	19	-	-	-	-	70	90	100	6.5	M5x12	28	40
80A1	14	15	15.875	16	19	-	-	-	-	80	100	100	5	M6x16	28	40
80AH1	14	15	15.875	16	19	-	-	-	-	80	100	100	5	6.5	28	40
95A	14	15	15.875	16	19	-	-	-	-	95	115	100	5	M8x18	28	40
95A1	14	15	15.875	16	19	22	24	-	-	95	115	100	5	M8x18	38	50
95B	14	15	15.875	16	19	-	-	-	-	95	130	115	5	M8x18	28	40
110A	14	15	15.875	16	19	-	-	-	-	110	130	115	5	M8x18	28	40
110A1	14	15	15.875	16	19	22	24	-	-	110	130	115	6.5	M8x20	38	50
110B	14	15	15.875	16	19	22	24	-	-	110	145	120	6.5	M8x20	38	50
110B1	14	15	15.875	16	19	22	24	28	-	110	145	120	6.5	M8x20	48	60
130A	14	15	15.875	16	19	22	24	-	-	130	165	140	6.5	M10x20	38	50
130A1	14	15	15.875	16	19	22	24	28	32	130	165	140	6.5	M10x25	48	60

Please contact us for different motor adapters and input shaft bore.

LC 120P

FM

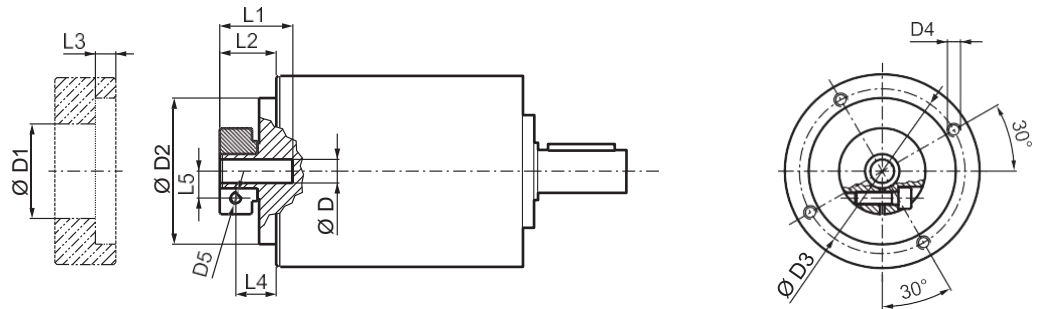

				D1	D2	D3	D4	D5	L1	L2	L3	L4	L5
14	15	15.875	16	48	90	98	M6x15	M6	33.5	20	7.6	12.5	14.5
19				51	90	98	M6x15	M6	33.5	20	7.6	12.5	16.5
22	24			56.5	90	98	M6x15	M6	36.5	23	7.6	14	19
28				67	90	98	M6x15	M8	36.5	23	7.6	14	22.5
32				71	90	98	M6x15	M8	38	24.5	7.6	15.5	24.5

	i	M _{n2} [Nm]	M _{a2} [Nm]	M _{p2} [Nm]	n ₁ [min ⁻¹]	n _{1 max} [min ⁻¹]	φ _S [arcmin]	φ _R [arcmin]	C _t $\frac{Nm}{arcmin}$	R _{2 max} [N]	A _{2 max} [N]	η %	J _G [kgcm ²]		
														14 ... 19	22 ; 24
LC 120P 1_3		155	280	300	3000	4000	12'	6'	30	3500	3000	97	2.17	2.77	3.13
LC 120P 1_4		155	300	360	3000	4500	12'	6'	30	3500	3000	97	1.30	1.89	2.26
LC 120P 1_5		125	240	360	3000	4500	12'	6'	25	3500	3000	97	0.96	1.56	1.92
LC 120P 1_7		125	240	360	3500	4500	12'	6'	25	3500	3000	97	0.66	1.26	1.62
LC 120P 1_10		100	165	300	3500	5000	12'	6'	25	3500	3000	97	0.49	1.09	1.45
LC 120P 2_9		155	280	300	3000	4000	15'	8'	30	3500	3000	94	1.61	2.20	2.57
LC 120P 2_12		155	300	360	3000	4000	15'	8'	30	3500	3000	94	1.51	2.10	2.47
LC 120P 2_15		155	300	360	3000	4000	15'	8'	30	3500	3000	94	1.47	2.06	2.43
LC 120P 2_16		155	300	360	3000	4500	15'	8'	30	3500	3000	94	0.92	1.52	1.88
LC 120P 2_20		155	300	360	3000	4500	15'	8'	30	3500	3000	94	0.90	1.50	1.86
LC 120P 2_25		125	240	360	3000	4500	15'	8'	22.5	3500	3000	94	0.71	1.30	1.67
LC 120P 2_28		125	240	360	3500	5000	15'	8'	22.5	3500	3000	94	0.54	1.13	1.50
LC 120P 2_30		155	300	300	3500	5000	15'	8'	30	3500	3000	94	0.44	1.04	1.40
LC 120P 2_35		125	240	360	3500	5000	15'	8'	22.5	3500	3000	94	0.53	1.13	1.49
LC 120P 2_40		155	300	360	3500	5000	15'	8'	30	3500	3000	94	0.43	1.03	1.39
LC 120P 2_50		125	240	360	3500	5000	15'	8'	22.5	3500	3000	94	0.43	1.02	1.39
LC 120P 2_70		125	240	360	3500	5000	15'	8'	22.5	3500	3000	94	0.42	1.02	1.38
LC 120P 2_100		100	165	300	3500	5000	15'	8'	22.5	3500	3000	94	0.42	1.02	1.38

LC



LCK Series

LCK precision planetary right-angle gearboxes represent a flexible, reliable and cost-effective solution for machines that require a very compact layout.

The output design in line with market standards ensures great compatibility for easy retrofits and a high level of freedom in projects development.

Main benefits

- Cost effective yet powerful
- High compatibility for easy retrofits
- Compact design for space-saving layouts

Main features

- Nominal output torque (Nm)
10 - 450
- Torsional backlash (arcmin)
6 - 8
- Torsional stiffness (Nm/arcmin)
0.7 - 47.9
- Max tilting moment (Nm)
15 - 522

Protection class

- IP54

Frame sizes

- 050
- 070
- 090
- 120
- 155

Main options

- Input versions
 - MOTOR ADAPTER
 - WITHOUT MOTOR ADAPTER
- Output shafts versions
 - SMOOTH KEYLESS SHAFT
 - KEYED SHAFT
- Lubrication
 - STANDARD LUBRICATION
 - UH1 FOOD GRADE LUBRICATION
- High power version (P option)
HIGH POWER VERSION

11 FEATURES OF LCK SERIES

Gear units of series LCK replicate in the right angle layout the brilliant features that are already typical of the in-line products of the LC series, with the additional benefit of a facilitated installation in tight spaces.

- Available in one only backlash option, corresponding to following values:
2-stage units: standard $\phi_S \leq 6'$;
3-stage units: standard $\phi_S \leq 8'$;
- Its degree of protection IP54 provides protection against dust and liquid splashes.
- Input section oil seals made from a Fluoroelastomer compound are supplied as standard.
- Noise pressure level $L_p \leq 70$ dB(A). Conditions: distance 1 m; measured without load an input speed of $n_1 = 3000 \text{ min}^{-1}$; $i=10$.
- Wide range of adapter flanges matching the most popular brands of motors
- Units are factory filled with synthetic grease to NLGI consistency class 00, in the absence of contamination the lubricant requires no periodical changes.
- Ambient temperature min -20°C , max $+30^\circ\text{C}$. For temperature higher than 30°C please consider derating factor f_T .
- Housing temperature must not exceed $T_{\text{max}} = 90^\circ\text{C}$.
- Available as Version P with higher output torque.

		Distribution of nominal torque M_{n2} [Nm]										
[i]	6	8	10	14	20	24	30	50	70	80	90	100
LCK 050	10	12	12	12	–	12	12	12	12	–	12	–
LCK 070	18	25	25	25	18	25	25	25	25	25	–	25
LCK 070P	25	30	28	28	20	29	29	30	30	30	–	30
LCK 090	37	43	43	43	37	43	43	43	43	43	–	43
LCK 090P	45	60	50	50	40	60	60	50	50	60	–	50
LCK 120	95	110	110	110	95	110	110	110	110	110	–	110
LCK 120P	110	140	125	125	100	155	155	125	125	155	–	125
LCK 155	250	300	300	300	230	300	300	300	300	300	–	300

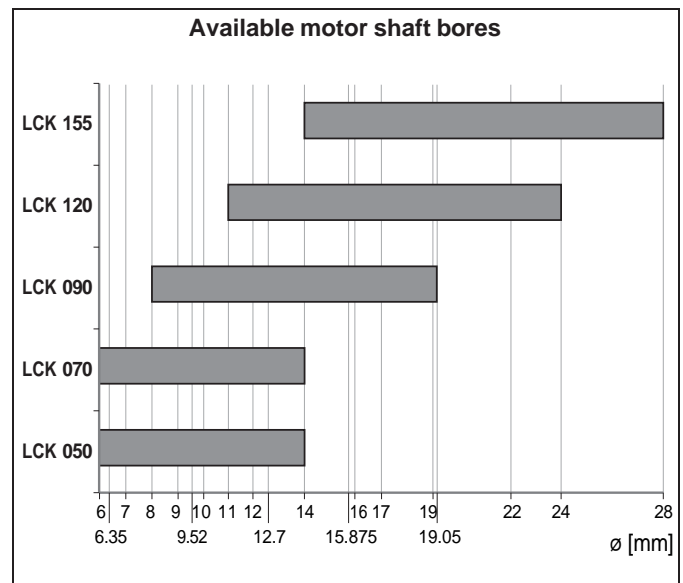
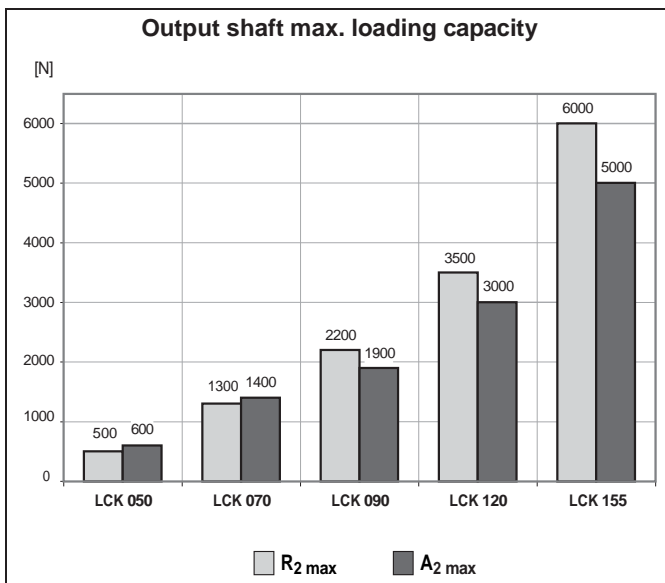

11.1 ORDERING CODE

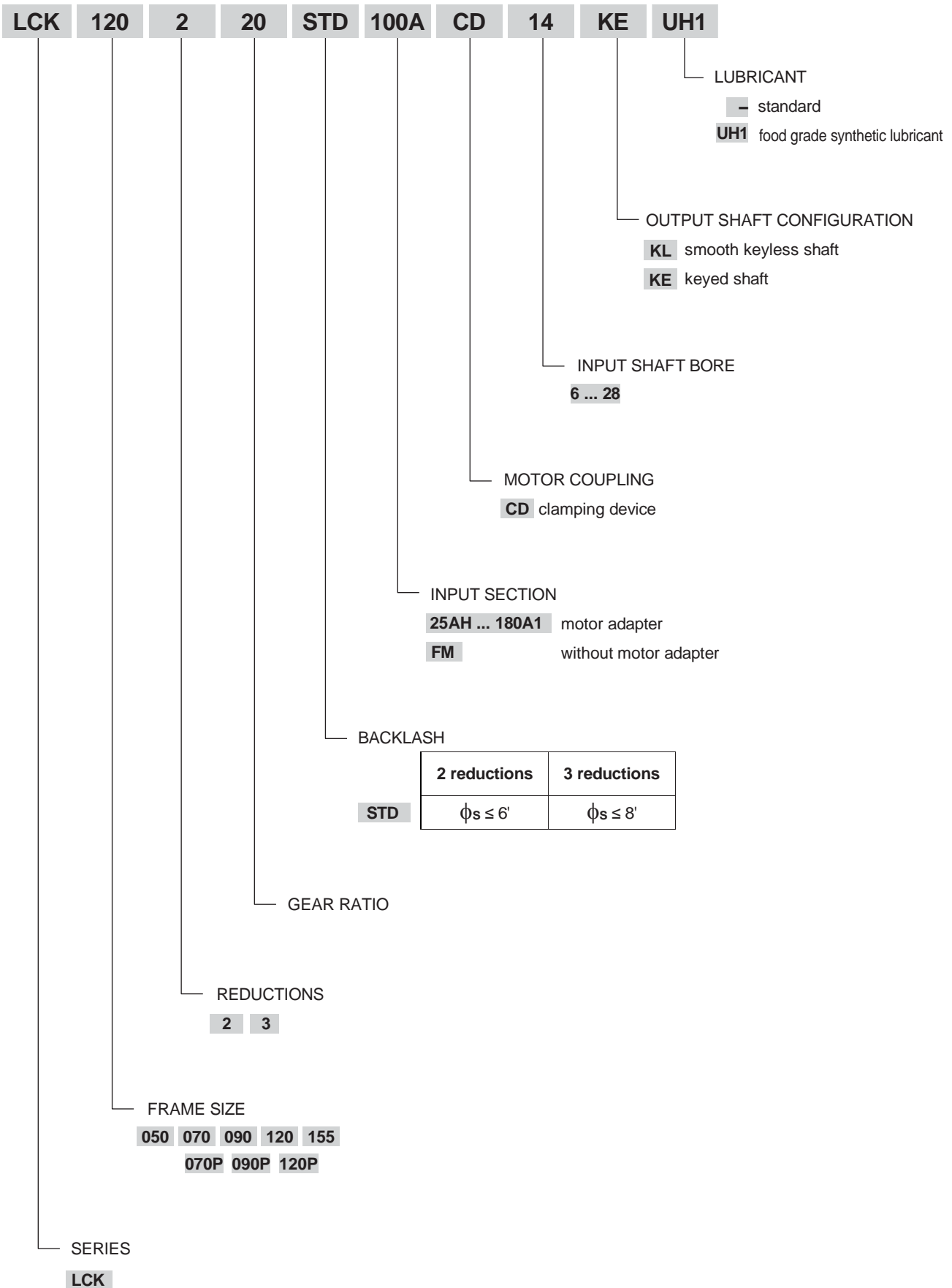

11.2 DIMENSIONS AND TECHNICAL SPECIFICATIONS

LCK 050

25AH ... 80A

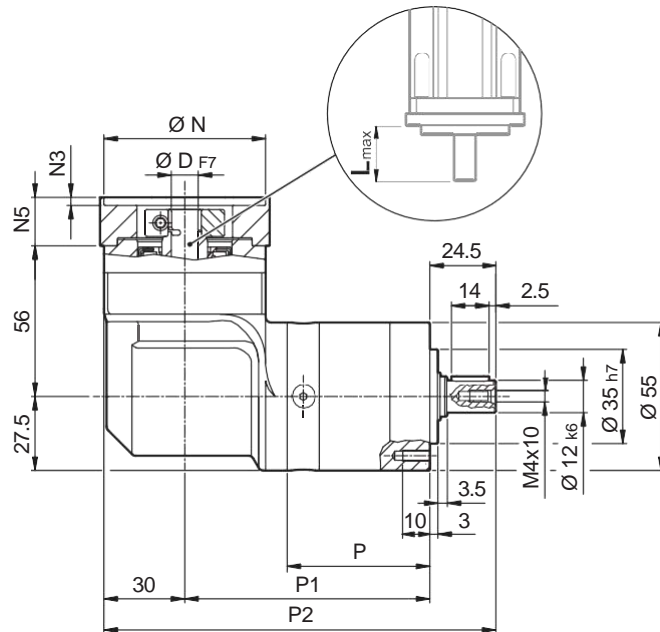
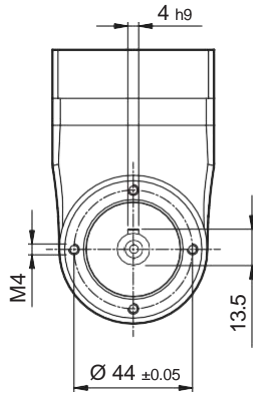

	P	P1	P2	
LCK 050 2	53	91	145.5	1.6
LCK 050 3	66.8	104.8	159.3	1.8

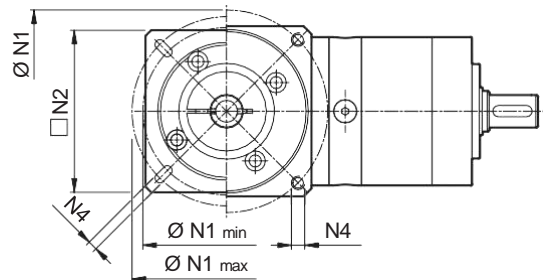

															N	N1		N2	N3	N4	N5	L _{max}	
	D	1	2	3	4	5	6	7	8	9	10	11	12	13		min	max						
25AH	6	6.35	7	8	9	9.52	-	-	-	-	-	-	-	-	25	39	56						
26AH	6	6.35	7	8	9	9.52	-	-	-	-	-	-	-	-	26	39	56						
28AH	6	6.35	7	8	9	9.52	-	-	-	-	-	-	-	-	28	39	56						
30AH	6	6.35	7	8	9	9.52	-	-	-	-	-	-	-	-	30	39	56						
32AH	6	6.35	7	8	9	9.52	-	-	-	-	-	-	-	-	32	39	56	65	3.5	4.5	25	25	
34AH	6	6.35	7	8	9	9.52	-	-	-	-	-	-	-	-	34	40	56						
36AH	6	6.35	7	8	9	9.52	-	-	-	-	-	-	-	-	36	42	56						
39AH	6	6.35	7	8	9	9.52	-	-	-	-	-	-	-	-	39	45	56						
40AH	6	6.35	7	8	9	9.52	-	-	-	-	-	-	-	-	40	46	56						
38B	6	6.35	7	8	9	9.52	10	11	12	12.7	-	-	-	-	38.1	66.6	60	3	M4x10	18	25		
40B	6	6.35	7	8	9	9.52	10	11	12	12.7	-	-	-	-	40	63	60	3	M4x10	18	25		
50A	6	6.35	7	8	9	9.52	10	11	12	12.7	-	-	-	-	50	60	60	3	M4x10	18	25		
50B	6	6.35	7	8	9	9.52	10	11	12	12.7	14	-	-	-	50	65	60	3	M5x12	23	30		
50BH	6	6.35	7	8	9	9.52	10	11	12	12.7	14	-	-	-	50	65	65	3	5.5	25	32		
50C	6	6.35	7	8	9	9.52	10	11	12	12.7	14	-	-	-	50	70	60	3	M4x10	23	30		
55MH	6	6.35	7	8	9	9.52	10	11	12	12.7	-	-	-	-	55	80	65	2	5.5	16	23		
60A	6	6.35	7	8	9	9.52	10	11	12	12.7	-	-	-	-	60	75	65	3	M5x12	18	25		
60A1	6	6.35	7	8	9	9.52	10	11	12	12.7	14	-	-	-	60	75	65	3	M5x12	23	30		
60B	6	6.35	7	8	9	9.52	10	11	12	12.7	14	-	-	-	60	85	75	3	M5x12	23	30		
60C	6	6.35	7	8	9	9.52	10	11	12	12.7	14	-	-	-	60	90	75	3	M5x12	23	30		
70A	6	6.35	7	8	9	9.52	10	11	12	12.7	14	-	-	-	70	85	75	3	M6x15	23	30		
70B	6	6.35	7	8	9	9.52	10	11	12	12.7	14	-	-	-	70	90	75	5	M5x12	23	30		
73A	6	6.35	7	8	9	9.52	10	11	12	12.7	14	-	-	-	73	98.4	85	3	M5x12	25	32		
80A	6	6.35	7	8	9	9.52	10	11	12	12.7	14	-	-	-	80	100	85	3	M6x15	23	30		

LCK 050

FM

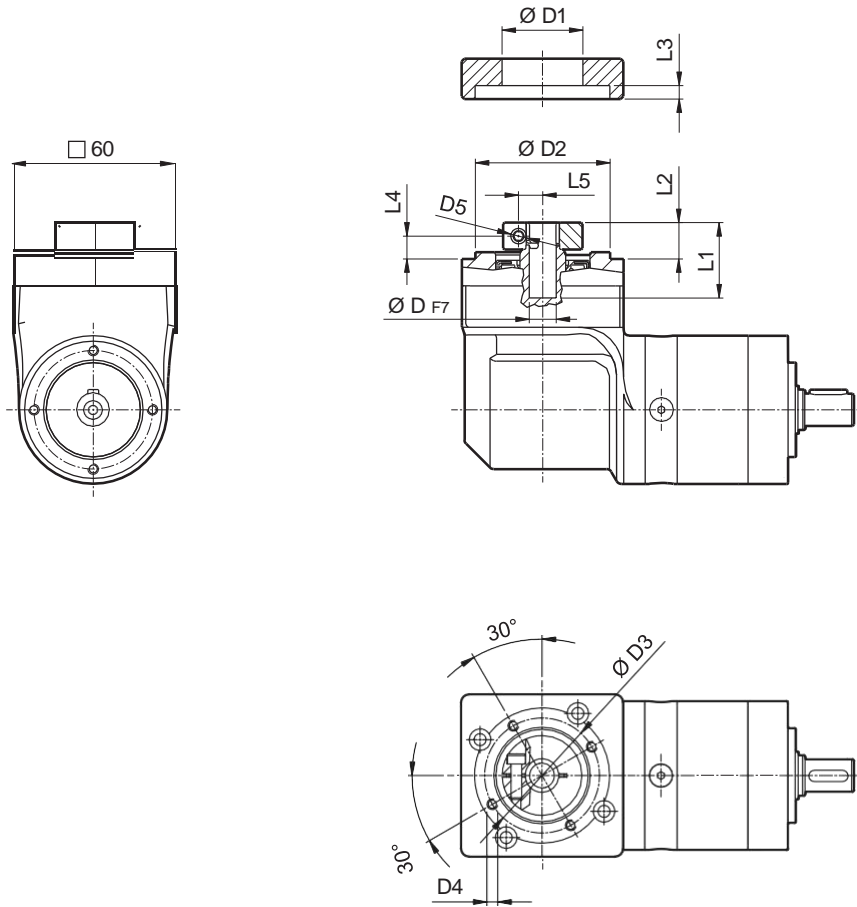

				D1	D2	D3	D4	D5	L1	L2	L3	L4	L5
6	6.35	7		32.5	50	42.5	M4x8	M4	28	13.5	3	8.5	8
8	9	9.52	10	32.5	50	42.5	M4x8	M4	28	13.5	3	8.5	9
11	12	12.7		35.5	50	42.5	M4x8	M4	23	13.5	3	8.5	11
14				35.5	50	42.5	M4x8	M4	25	15.5	3	8.9	11.5

	i	M _{n2} [Nm]	M _{a2} [Nm]	M _{p2} [Nm]	n ₁ [min ⁻¹]	n _{1 max} [min ⁻¹]	φ _s [arcmin]	C _t $\frac{Nm}{arcmin}$	R _{2 max} [N]	A _{2 max} [N]	η %	J _G [kgcm ²]	
													6 ... 9.52
LCK 050 2_6		10	16	28	2500	5000	6'	0.9	500	600	94	0.23	0.25
LCK 050 2_8		12	20	30	2500	5000	6'	0.9	500	600	94	0.23	0.24
LCK 050 2_10		12	20	30	2500	5000	6'	0.9	500	600	94	0.23	0.24
LCK 050 2_14		12	20	30	2500	5000	6'	0.9	500	600	94	0.23	0.24
LCK 050 3_24		12	20	30	2500	5000	8'	0.7	500	600	91	0.23	0.25
LCK 050 3_30		12	20	30	2500	5000	8'	0.7	500	600	91	0.23	0.25
LCK 050 3_50		12	20	30	2500	5000	8'	0.7	500	600	91	0.23	0.24
LCK 050 3_70		12	20	30	2500	5000	8'	0.7	500	600	91	0.23	0.24
LCK 050 3_90		12	20	30	2500	5000	8'	0.7	500	600	91	0.22	0.24

LCK

Please contact us for different motor adapters and input shaft bore.

LCK 070

25AH ... 80A

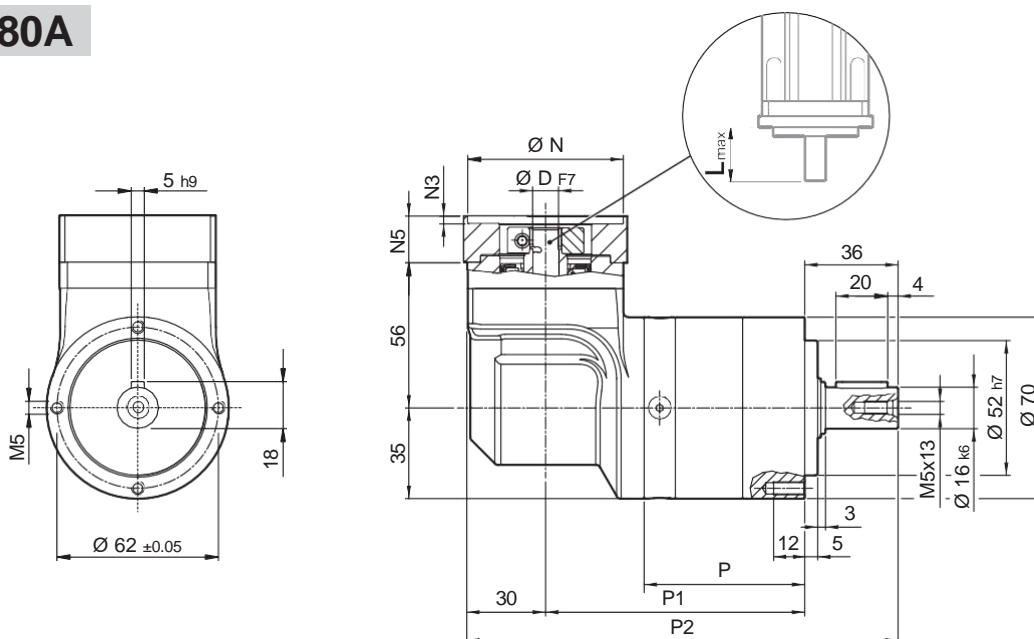

	P	P1	P2	KG
LCK 070 2	62	100	166	2.7
LCK 070 3	78.7	116.7	182.7	3.0

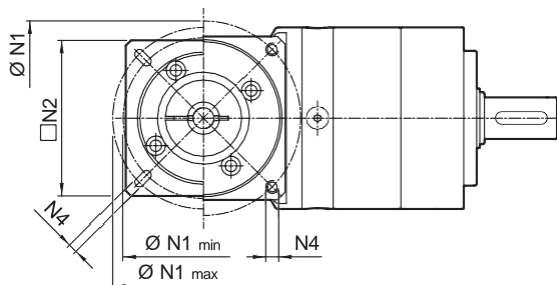

															N	N1		N2	N3	N4	N5	L _{max}	
	D	1	2	3	4	5	6	7	8	9	10	11	12	13		14	min						max
25AH	6	6.35	7	8	9	9.52	-	-	-	-	-	-	-	-	25	39	56						
26AH	6	6.35	7	8	9	9.52	-	-	-	-	-	-	-	-	26	39	56						
28AH	6	6.35	7	8	9	9.52	-	-	-	-	-	-	-	-	28	39	56						
30AH	6	6.35	7	8	9	9.52	-	-	-	-	-	-	-	-	30	39	56						
32AH	6	6.35	7	8	9	9.52	-	-	-	-	-	-	-	-	32	39	56	65	3.5	4.5	25	25	
34AH	6	6.35	7	8	9	9.52	-	-	-	-	-	-	-	-	34	40	56						
36AH	6	6.35	7	8	9	9.52	-	-	-	-	-	-	-	-	36	42	56						
39AH	6	6.35	7	8	9	9.52	-	-	-	-	-	-	-	-	39	45	56						
40AH	6	6.35	7	8	9	9.52	-	-	-	-	-	-	-	-	40	46	56						
38B	6	6.35	7	8	9	9.52	10	11	12	12.7	-	-	-	-	38.1	66.6	60	3	M4x10	18	25		
40B	6	6.35	7	8	9	9.52	10	11	12	12.7	-	-	-	-	40	63	60	3	M4x10	18	25		
50A	6	6.35	7	8	9	9.52	10	11	12	12.7	-	-	-	-	50	60	60	3	M4x10	18	25		
50B	6	6.35	7	8	9	9.52	10	11	12	12.7	14	-	-	-	50	65	60	3	M5x12	23	30		
50BH	6	6.35	7	8	9	9.52	10	11	12	12.7	14	-	-	-	50	65	65	3	5.5	25	32		
50C	6	6.35	7	8	9	9.52	10	11	12	12.7	14	-	-	-	50	70	60	3	M4x10	23	30		
55MH	6	6.35	7	8	9	9.52	10	11	12	12.7	-	-	-	-	55	80	65	2	5.5	16	23		
60A	6	6.35	7	8	9	9.52	10	11	12	12.7	-	-	-	-	60	75	65	3	M5x12	18	25		
60A1	6	6.35	7	8	9	9.52	10	11	12	12.7	14	-	-	-	60	75	65	3	M5x12	23	30		
60B	6	6.35	7	8	9	9.52	10	11	12	12.7	14	-	-	-	60	85	75	3	M5x12	23	30		
60C	6	6.35	7	8	9	9.52	10	11	12	12.7	14	-	-	-	60	90	75	3	M5x12	23	30		
70A	6	6.35	7	8	9	9.52	10	11	12	12.7	14	-	-	-	70	85	75	3	M6x15	23	30		
70B	6	6.35	7	8	9	9.52	10	11	12	12.7	14	-	-	-	70	90	75	5	M5x12	23	30		
73A	6	6.35	7	8	9	9.52	10	11	12	12.7	14	-	-	-	73	98.4	85	3	M5x12	25	32		
80A	6	6.35	7	8	9	9.52	10	11	12	12.7	14	-	-	-	80	100	85	3	M6x15	23	30		

LCK 070

FM

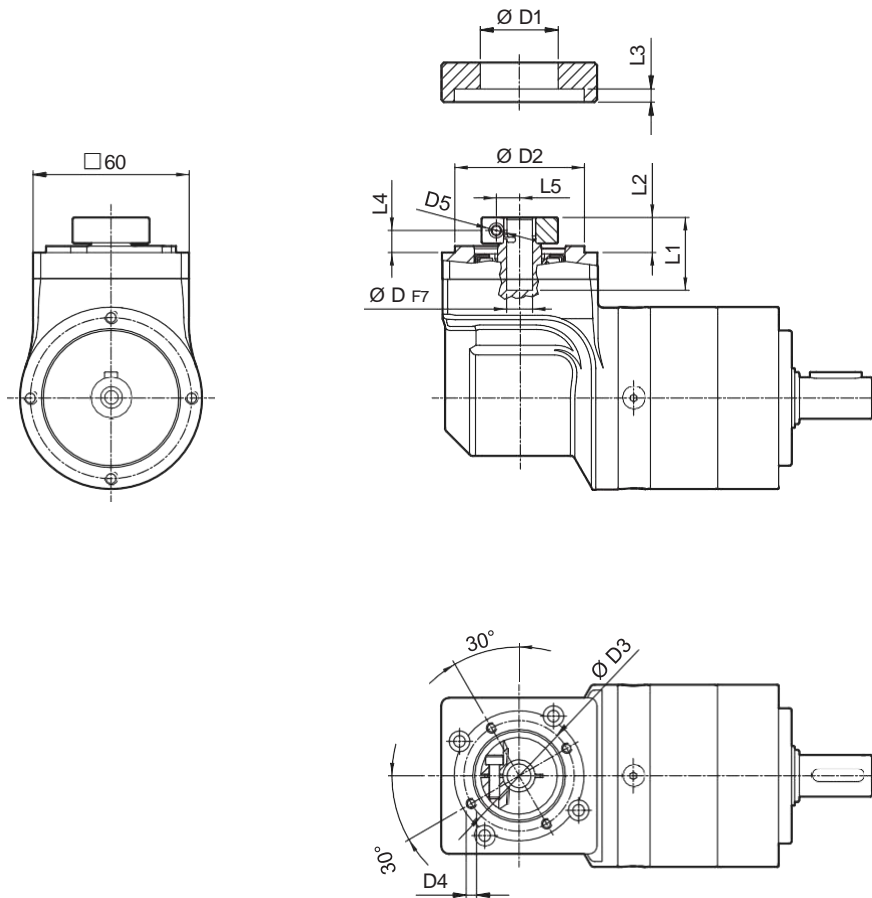

				D1	D2	D3	D4	D5	L1	L2	L3	L4	L5
6	6.35	7		32.5	50	42.5	M4x8	M4	28	13.5	3	8.5	8
8	9	9.52	10	32.5	50	42.5	M4x8	M4	28	13.5	3	8.5	9
11	12	12.7		35.5	50	42.5	M4x8	M4	23	13.5	3	8.5	11
14				35.5	50	42.5	M4x8	M4	25	15.5	3	8.9	11.5

	i	M _{n2}	M _{a2}	M _{p2}	n ₁	n _{1 max}	φ _s	C _t	R _{2 max}	A _{2 max}	η	J _G [kgcm ²]	
		[Nm]	[Nm]	[Nm]	[min ⁻¹]	[min ⁻¹]	[arcmin]	$\frac{Nm}{arcmin}$	[N]	[N]	%	6 ... 9.52	10 ... 14
LCK 070 2_6		18	30	45	2500	5000	6'	2.8	1300	1400	94	0.25	0.26
LCK 070 2_8		25	35	60	2500	5000	6'	2.8	1300	1400	94	0.24	0.25
LCK 070 2_10		28	40	70	2500	5000	6'	2.8	1300	1400	94	0.23	0.25
LCK 070 2_14		28	40	70	2500	5000	6'	2.8	1300	1400	94	0.23	0.24
LCK 070 2_20		20	33	60	2500	5000	6'	2.8	1300	1400	94	0.23	0.24
LCK 070 3_24		25	35	70	2500	5000	8'	2.5	1300	1400	91	0.24	0.26
LCK 070 3_30		25	35	70	2500	5000	8'	2.5	1300	1400	91	0.24	0.26
LCK 070 3_50		25	35	70	2500	5000	8'	2.5	1300	1400	91	0.23	0.24
LCK 070 3_70		25	35	70	2500	5000	8'	2.5	1300	1400	91	0.23	0.24
LCK 070 3_80		25	35	70	2500	5000	8'	2.5	1300	1400	91	0.23	0.24
LCK 070 3_100		25	35	70	2500	5000	8'	2.5	1300	1400	91	0.23	0.24

Please contact us for different motor adapters and input shaft bore.

LCK 090

40B1 ... 110B1

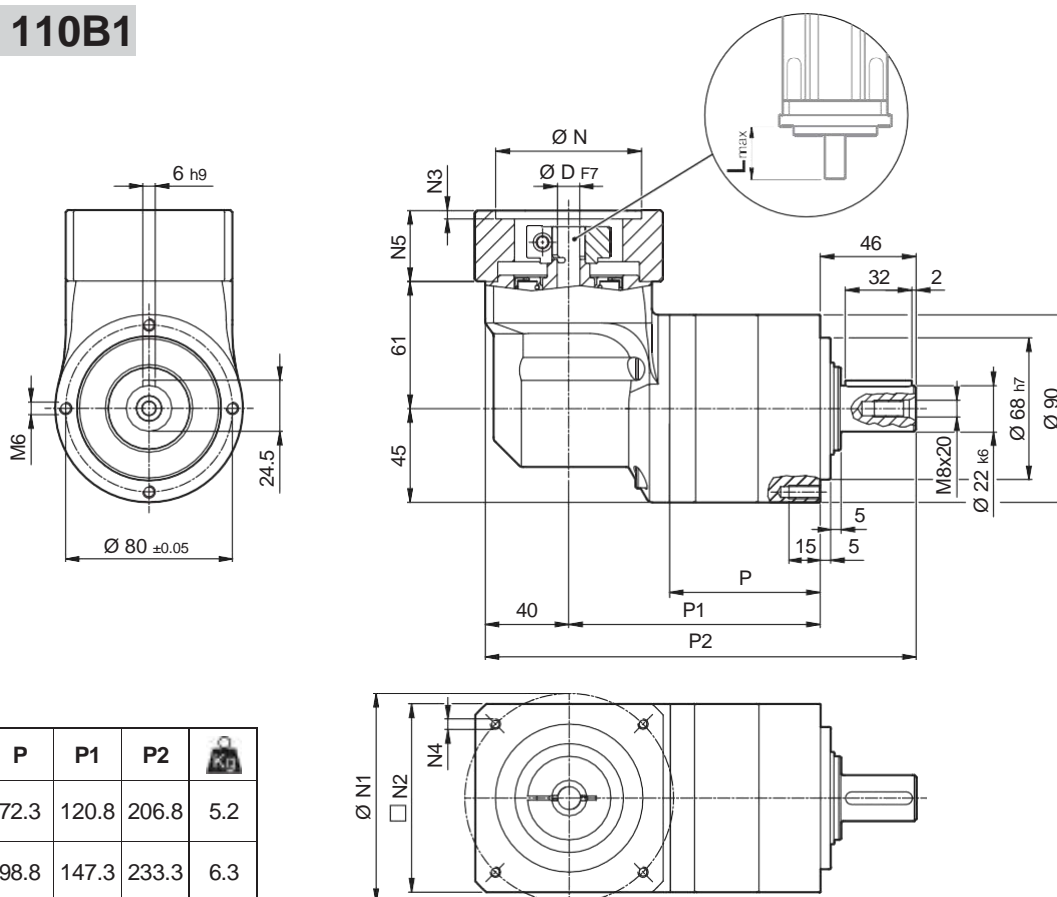



	P	P1	P2	
LCK 090 2	72.3	120.8	206.8	5.2
LCK 090 3	98.8	147.3	233.3	6.3

											N	N1	N2	N3	N4	N5	L _{max}		
	8	9	9.52	11	12	12.7	14	-	-	-									
40B1	8	9	9.52	11	12	12.7	14	-	-	-	-	40	63	80	4	M4x10	34	40	
45A	8	9	9.52	11	12	12.7	-	-	-	-	-	45	63	80	4	M4x10	34	40	
50B1	8	9	9.52	11	12	12.7	14	-	-	-	-	50	65	80	4	M5x16	34	40	
50BH1	8	9	9.52	11	12	12.7	14	-	-	-	-	50	65	80	4	5.5	34	40	
50C1	8	9	9.52	11	12	12.7	14	-	-	-	-	50	70	80	4	M4x10	34	40	
50D	8	9	9.52	11	12	12.7	14	-	-	-	-	50	95	80	4	M6x10	34	40	
55A	8	9	9.52	11	12	12.7	14	15.875	16	17	19	19.05	55.5	125.7	105	4	M6x16	34	40
60A2	8	9	9.52	11	12	12.7	14	-	-	-	-	60	75	80	4	M5x16	34	40	
60AH2	8	9	9.52	11	12	12.7	14	-	-	-	-	60	75	90	4	5.5	34	40	
60B1	8	9	9.52	11	12	12.7	14	15.875	16	-	-	60	85	80	4	M5x16	34	40	
60C1	8	9	9.52	11	12	12.7	14	15.875	16	-	-	60	90	80	4	M5x16	34	40	
70A1	8	9	9.52	11	12	12.7	14	15.875	16	17	19	19.05	70	85	80	4	M6x20	34	40
70AH1	8	9	9.52	11	12	12.7	14	15.875	16	17	19	19.05	70	85	90	4	6.5	34	40
70B1	8	9	9.52	11	12	12.7	14	15.875	16	17	19	19.05	70	90	80	4	M5x16	34	40
73A1	8	9	9.52	11	12	12.7	14	-	-	-	-	73	98.4	85	4	M5x16	34	40	
80A1	8	9	9.52	11	12	12.7	14	15.875	16	17	19	19.05	80	100	90	4	M6x16	34	40
95A	8	9	9.52	11	12	12.7	14	15.875	16	17	19	19.05	95	115	100	4	M8x20	34	40
95B	8	9	9.52	11	12	12.7	14	15.875	16	17	19	19.05	95	130	115	4	M8x20	34	40
110A	8	9	9.52	11	12	12.7	14	15.875	16	17	19	19.05	110	130	115	4	M8x20	34	40
110B	8	9	9.52	11	12	12.7	14	15.875	16	17	19	19.05	110	145	120	6.5	M8x20	44	50
110B1	8	9	9.52	11	12	12.7	14	15.875	16	17	19	19.05	110	145	120	6.5	M8x20	54	60

LCK 090

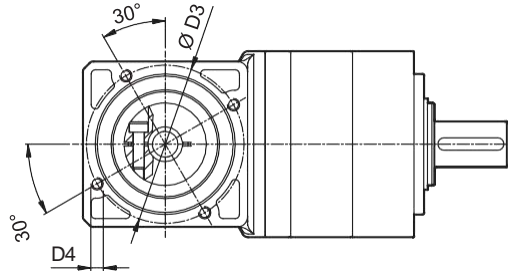
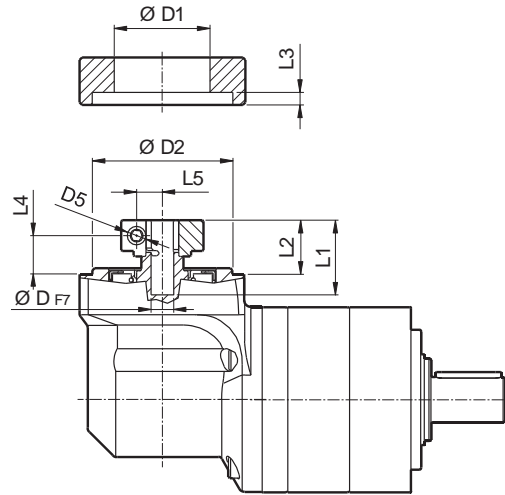
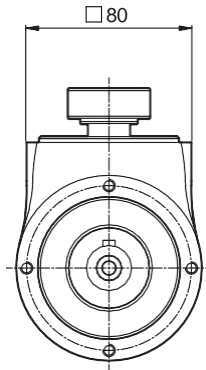
FM

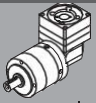

			D1	D2	D3	D4	D5	L1	L2	L3	L4	L5
8	9	9.52	38	68	76.5	M6x10	M6	36.3	26.3	9.5	18.8	10.5
11	12	12.7	43	68	76.5	M6x10	M6	36.3	26.3	9.5	18.8	12.5
14	15.875	16	48	68	76.5	M6x10	M6	36.3	26.3	9.5	18.8	14.5
19	19.05		51	68	76.5	M6x10	M6	36.3	26.3	9.5	18.8	16.5

	i	M _{n2}	M _{a2}	M _{p2}	n ₁	n _{1 max}	φ _s	C _t	R _{2 max}	A _{2 max}	η	J _G [kgcm ²]	
		[Nm]	[Nm]	[Nm]	[min ⁻¹]	[min ⁻¹]	[arcmin]	$\frac{Nm}{arcmin}$	[N]	[N]	%	8 ... 12.7	14 ... 19.05
LCK 090 2_6		37	63	90	2500	5000	6'	8	2200	1900	94	0.85	1.03
LCK 090 2_8		43	80	120	2500	5000	6'	8	2200	1900	94	0.79	0.98
LCK 090 2_10		43	80	150	2500	5000	6'	8	2200	1900	94	0.77	0.96
LCK 090 2_14		43	80	160	2500	5000	6'	8	2200	1900	94	0.75	0.94
LCK 090 2_20		40	75	150	2500	5000	6'	8	2200	1900	94	0.74	0.93
LCK 090 3_24		43	80	160	2500	5000	8'	7.8	2200	1900	91	0.81	1.00
LCK 090 3_30		43	80	160	2500	5000	8'	7.8	2200	1900	91	0.81	1.00
LCK 090 3_50		43	80	160	2500	5000	8'	7.8	2200	1900	91	0.76	0.94
LCK 090 3_70		43	80	160	2500	5000	8'	7.8	2200	1900	91	0.74	0.93
LCK 090 3_80		43	80	160	2500	5000	8'	7.8	2200	1900	91	0.74	0.93
LCK 090 3_100		43	80	160	2500	5000	8'	7.8	2200	1900	91	0.74	0.93

LCK

Please contact us for different motor adapters and input shaft bore.

LCK 120

50D ... 130A1

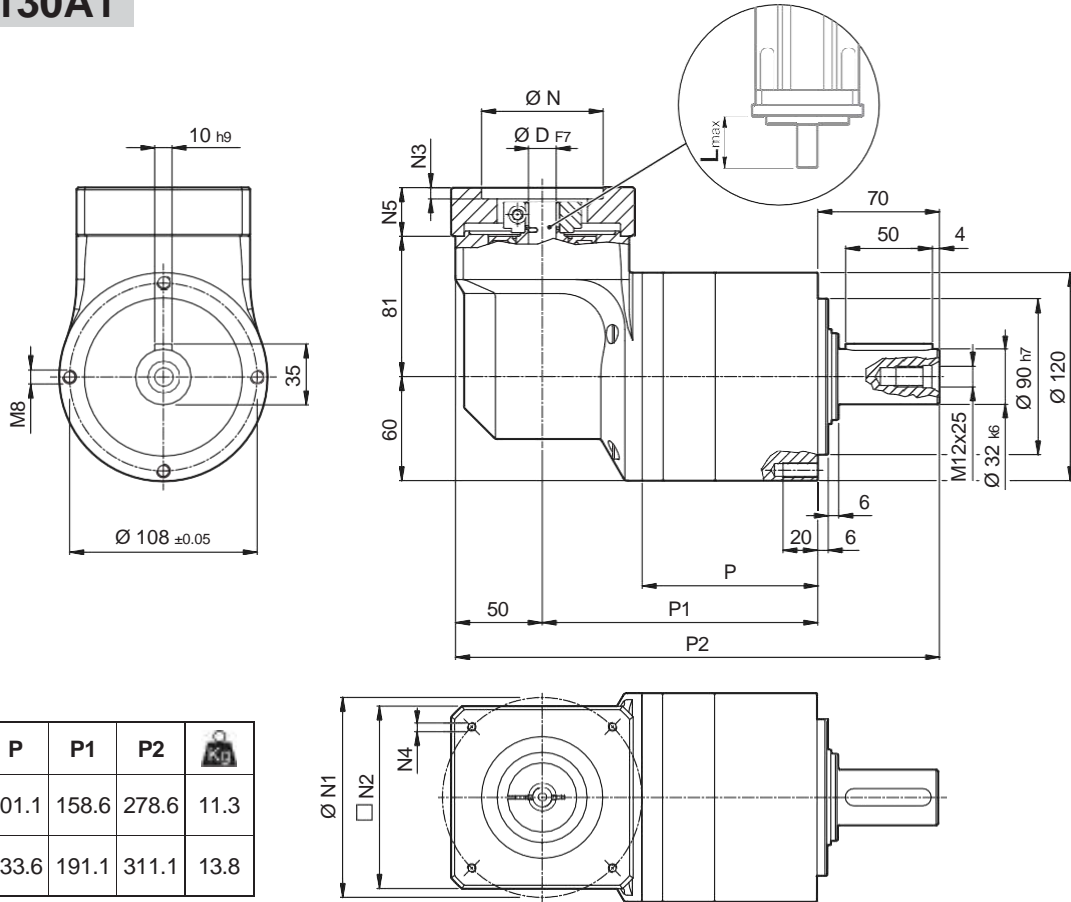

	P	P1	P2	
LCK 120 2	101.1	158.6	278.6	11.3
LCK 120 3	133.6	191.1	311.1	13.8

LCK

											N	N1	N2	N3	N4	N5	L _{max}
50D	11	12	12.7	14	15	15.875	16	19	-	-	50	95	100	5	M6x14	28	40
55A	11	12	12.7	14	15	15.875	16	19	-	-	55.5	125.7	105	5	M6x16	28	40
60A2	11	12	12.7	14	15	15.875	16	19	-	-	60	75	100	5	M5x14	28	40
60AH2	11	12	12.7	14	15	15.875	16	19	-	-	60	75	100	5	6.5	33	40
60B1	11	12	12.7	14	15	15.875	16	19	-	-	60	85	100	6.5	M5x14	28	40
70A1	11	12	12.7	14	15	15.875	16	19	-	-	70	85	100	5	M6x14	28	40
70AH1	11	12	12.7	14	15	15.875	16	19	-	-	70	85	100	5	6	33	40
70B1	11	12	12.7	14	15	15.875	16	19	-	-	70	90	100	6.5	M5x12	28	40
80A1	11	12	12.7	14	15	15.875	16	19	-	-	80	100	100	5	M6x16	28	40
80AH1	11	12	12.7	14	15	15.875	16	19	-	-	80	100	100	5	6.5	28	40
95A	11	12	12.7	14	15	15.875	16	19	-	-	95	115	100	5	M8x18	28	40
95A1	11	12	12.7	14	15	15.875	16	19	22	24	95	115	100	5	M8x18	38	50
95B	11	12	12.7	14	15	15.875	16	19	-	-	95	130	115	5	M8x18	28	40
110A	11	12	12.7	14	15	15.875	16	19	-	-	110	130	115	5	M8x18	28	40
110A1	11	12	12.7	14	15	15.875	16	19	22	24	110	130	115	6.5	M8x20	38	50
110B	11	12	12.7	14	15	15.875	16	19	22	24	110	145	120	6.5	M8x20	38	50
110B1	11	12	12.7	14	15	15.875	16	19	22	24	110	145	120	6.5	M8x20	48	60
130A	11	12	12.7	14	15	15.875	16	19	22	24	130	165	140	6.5	M10x20	38	50
130A1	11	12	12.7	14	15	15.875	16	19	22	24	130	165	140	6.5	M10x25	48	60

LCK 120

FM

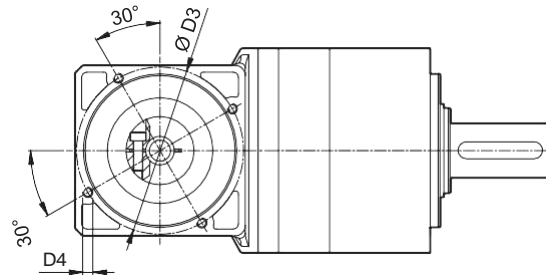
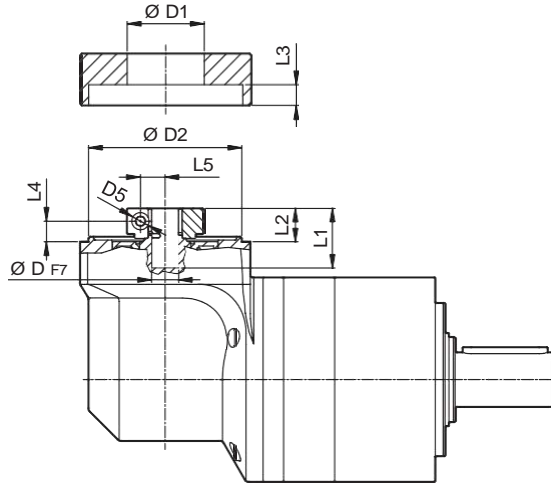
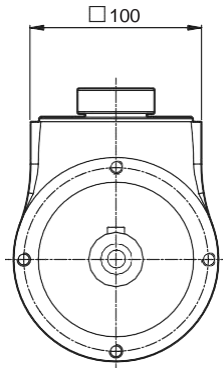

				D1	D2	D3	D4	D5	L1	L2	L3	L4	L5
11	12	12.7		43	90	98	M6x15	M6	35	19.5	7.6	12.1	12.5
14	15	15.875	16	48	90	98	M6x15	M6	35	19.5	7.6	12.1	14.5
19				51	90	98	M6x15	M6	35	19.5	7.6	12.1	16.5
22	24			56.5	90	98	M6x15	M6	37	21.5	7.6	12.1	19

	i	M _{n2} [Nm]	M _{a2} [Nm]	M _{p2} [Nm]	n ₁ [min ⁻¹]	n _{1 max} [min ⁻¹]	φ _s [arcmin]	C _t <small>Nm per arcmin</small>	R _{2 max} [N]	A _{2 max} [N]	η %	J _G [kgcm ²]		
													11 ... 12.7	14 ... 19
LCK 120 2_6		95	160	225	2000	4500	6'	23.4	3500	3000	94	1.74	1.82	2.01
LCK 120 2_8		110	190	300	2000	4500	6'	23.4	3500	3000	94	1.52	1.60	1.79
LCK 120 2_10		110	190	360	2000	4500	6'	23.4	3500	3000	94	1.44	1.52	1.71
LCK 120 2_14		110	190	360	2000	4500	6'	23.4	3500	3000	94	1.37	1.45	1.63
LCK 120 2_20		100	165	300	2000	4500	6'	23.4	3500	3000	94	1.32	1.40	1.59
LCK 120 3_24		110	190	360	2000	4500	8'	22.9	3500	3000	91	1.64	1.72	1.90
LCK 120 3_30		110	190	360	2000	4500	8'	22.9	3500	3000	91	1.63	1.71	1.89
LCK 120 3_50		110	190	360	2000	4500	8'	22.9	3500	3000	91	1.40	1.48	1.67
LCK 120 3_70		110	190	360	2000	4500	8'	22.9	3500	3000	91	1.34	1.42	1.61
LCK 120 3_80		110	190	360	2000	4500	8'	22.9	3500	3000	91	1.31	1.39	1.58
LCK 120 3_100		110	190	360	2000	4500	8'	22.9	3500	3000	91	1.31	1.39	1.58

LCK

Please contact us for different motor adapters and input shaft bore.

LCK 155

55A1 ... 180A1

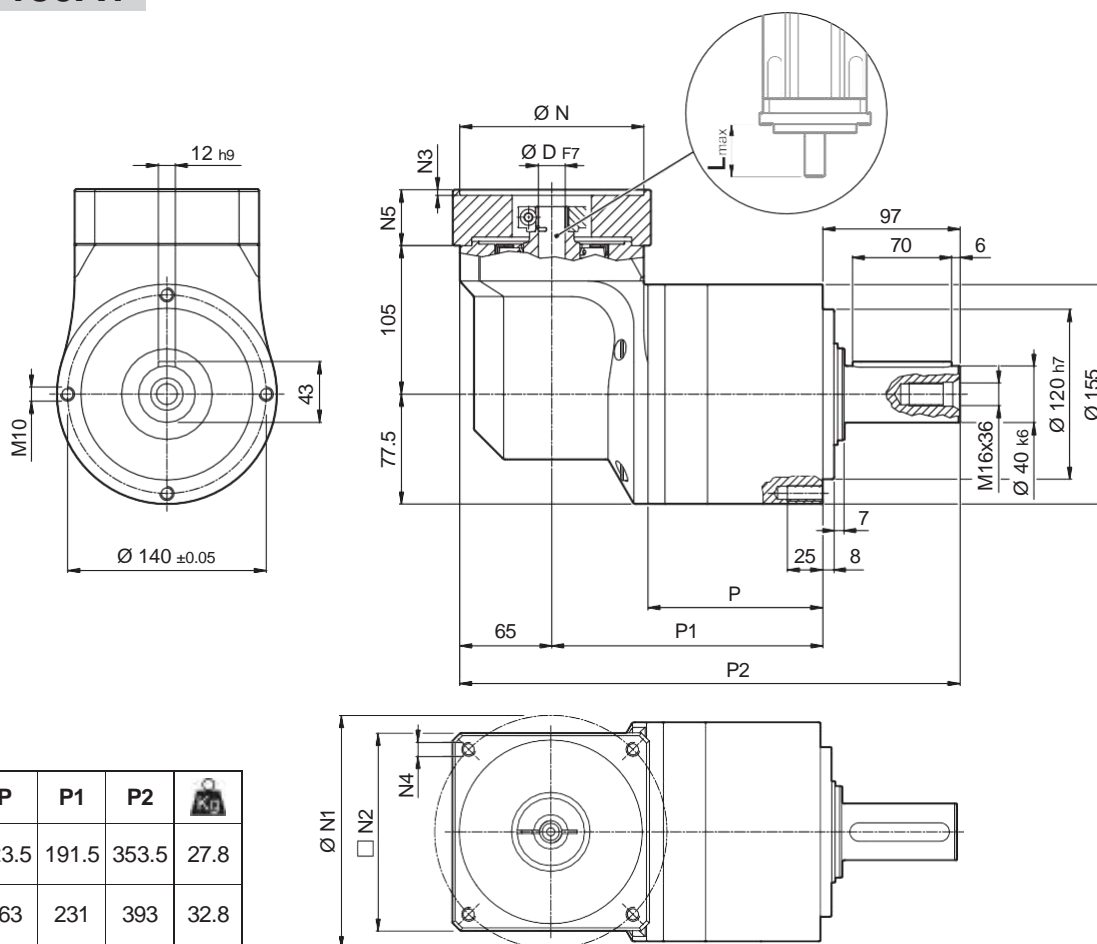



	P	P1	P2	
LCK 155 2	123.5	191.5	353.5	27.8
LCK 155 3	163	231	393	32.8

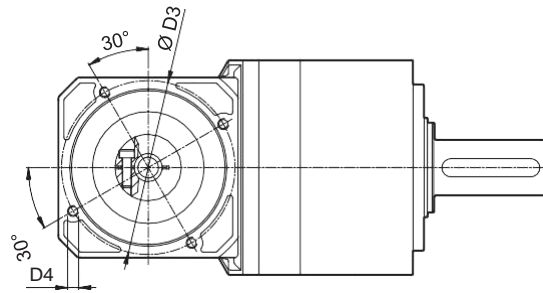
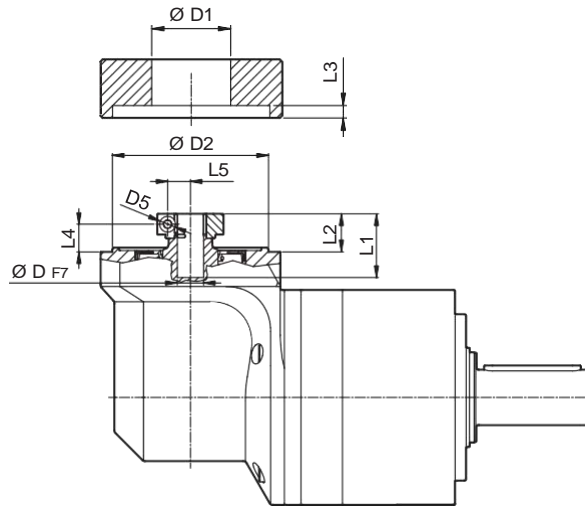
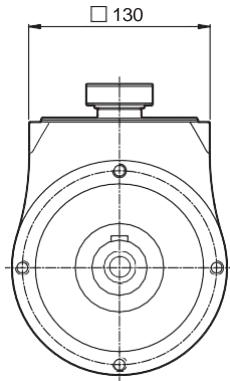

								N	N1	N2	N3	N4	N5	L _{max}
55A1	14	15.875	16	19	-	-	-	55.5	125.7	130	4	M6x15	39.5	50
80A2	14	15.875	16	19	-	-	-	80	100	130	4	M6x15	39.5	50
95A1	14	15.875	16	19	22	24	-	95	115	130	4	M8x20	39.5	50
110A1	14	15.875	16	19	22	24	-	110	130	130	4	M8x20	39.5	50
110B1	14	15.875	16	19	22	24	-	110	145	130	6.5	M8x20	49.5	60
114A	14	15.875	16	19	22	24	28	114.3	200	170	5.5	M12x25	69.5	80
130A	14	15.875	16	19	22	24	-	130	165	140	4	M10x20	39.5	50
130A1	14	15.875	16	19	22	24	28	130	165	140	4	M10x20	49.5	60
180A	14	15.875	16	19	22	24	28	180	215	190	5.5	M14x25	49.5	60
180A1	14	15.875	16	19	22	24	28	180	215	190	5.5	M14x25	69.5	80

LCK 155

FM



	D	D1	D2	D3	D4	D5	L1	L2	L3	L4	L5	
14	15.875	16	48	113	125.5	M8x15	M6	46	27.5	6	20	14.5
19			51	113	125.5	M8x15	M6	46	27.5	6	20	16.5
22	24		56.5	113	125.5	M8x15	M6	47.5	29	6	20	19
28			67	113	125.5	M8x15	M8	47.5	29	6	20	22.5

	i	M _{n2}	M _{a2}	M _{p2}	n ₁	n _{1 max}	φ _s	C _t	R _{2 max}	A _{2 max}	η	J _G [kgcm ²]		
		[Nm]	[Nm]	[Nm]	[min ⁻¹]	[min ⁻¹]	[arcmin]	$\frac{N \cdot m}{arcmin}$	[N]	[N]	%		14 ... 19	22 ; 24
LCK 155 2_6		250	360	510	2000	4500	6'	40.7	6000	5000	94	7.94	8.13	8.53
LCK 155 2_8		300	450	680	2000	4500	6'	40.7	6000	5000	94	7.11	7.30	7.70
LCK 155 2_10		300	450	850	2000	4500	6'	40.7	6000	5000	94	6.78	6.96	7.36
LCK 155 2_14		300	450	900	2000	4500	6'	40.7	6000	5000	94	6.48	6.67	7.07
LCK 155 2_20		230	350	750	2000	4500	6'	40.7	6000	5000	94	6.31	6.49	6.90
LCK 155 3_24		300	450	900	2000	4500	8'	37.4	6000	5000	91	7.18	7.37	7.77
LCK 155 3_30		300	450	900	2000	4500	8'	37.4	6000	5000	91	7.14	7.33	7.73
LCK 155 3_50		300	450	900	2000	4500	8'	37.4	6000	5000	91	6.49	6.68	7.08
LCK 155 3_70		300	450	900	2000	4500	8'	37.4	6000	5000	91	6.33	6.52	6.92
LCK 155 3_80		300	450	700	2000	4500	8'	37.4	6000	5000	91	6.25	6.43	6.83
LCK 155 3_100		300	450	900	2000	4500	8'	37.4	6000	5000	91	6.24	6.43	6.83

LCK

Please contact us for different motor adapters and input shaft bore.

LCK 070P

25AH ... 80A

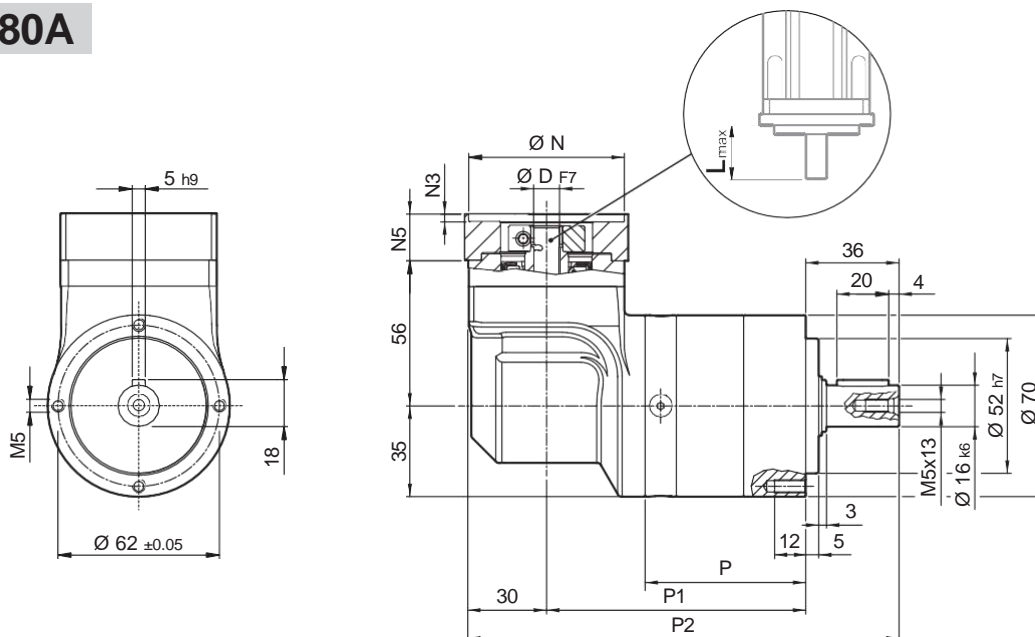

	P	P1	P2	
LCK 070P 2	62	100	166	2.7
LCK 070P 3	78.7	116.7	182.7	3.0

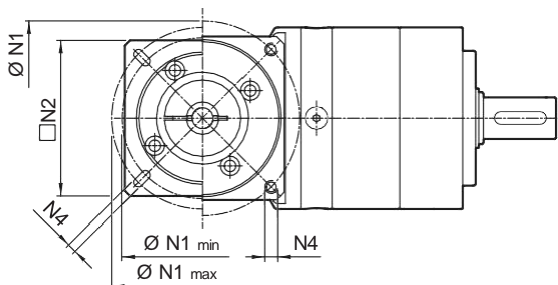

															N	N1		N2	N3	N4	N5	L _{max}
	D	6	6.35	7	8	9	9.52	10	11	12	12.7	14	min	max								
25AH	D	6	6.35	7	8	9	9.52	-	-	-	-	-	25	39	56							
26AH	D	6	6.35	7	8	9	9.52	-	-	-	-	-	26	39	56							
28AH	D	6	6.35	7	8	9	9.52	-	-	-	-	-	28	39	56							
30AH	D	6	6.35	7	8	9	9.52	-	-	-	-	-	30	39	56							
32AH	D	6	6.35	7	8	9	9.52	-	-	-	-	-	32	39	56	65	3.5	4.5	25	25		
34AH	D	6	6.35	7	8	9	9.52	-	-	-	-	-	34	40	56							
36AH	D	6	6.35	7	8	9	9.52	-	-	-	-	-	36	42	56							
39AH	D	6	6.35	7	8	9	9.52	-	-	-	-	-	39	45	56							
40AH	D	6	6.35	7	8	9	9.52	-	-	-	-	-	40	46	56							
38B	D	6	6.35	7	8	9	9.52	10	11	12	12.7	-	38.1	66.6	60	3	M4x10	18	25			
40B	D	6	6.35	7	8	9	9.52	10	11	12	12.7	-	40	63	60	3	M4x10	18	25			
50A	D	6	6.35	7	8	9	9.52	10	11	12	12.7	-	50	60	60	3	M4x10	18	25			
50B	D	6	6.35	7	8	9	9.52	10	11	12	12.7	14	50	65	60	3	M5x12	23	30			
50BH	D	6	6.35	7	8	9	9.52	10	11	12	12.7	14	50	65	65	3	5.5	25	32			
50C	D	6	6.35	7	8	9	9.52	10	11	12	12.7	14	50	70	60	3	M4x10	23	30			
55MH	D	6	6.35	7	8	9	9.52	10	11	12	12.7	-	55	80	65	2	5.5	16	23			
60A	D	6	6.35	7	8	9	9.52	10	11	12	12.7	-	60	75	65	3	M5x12	18	25			
60A1	D	6	6.35	7	8	9	9.52	10	11	12	12.7	14	60	75	65	3	M5x12	23	30			
60B	D	6	6.35	7	8	9	9.52	10	11	12	12.7	14	60	85	75	3	M5x12	23	30			
60C	D	6	6.35	7	8	9	9.52	10	11	12	12.7	14	60	90	75	3	M5x12	23	30			
70A	D	6	6.35	7	8	9	9.52	10	11	12	12.7	14	70	85	75	3	M6x15	23	30			
70B	D	6	6.35	7	8	9	9.52	10	11	12	12.7	14	70	90	75	5	M5x12	23	30			
73A	D	6	6.35	7	8	9	9.52	10	11	12	12.7	14	73	98.4	85	3	M5x12	25	32			
80A	D	6	6.35	7	8	9	9.52	10	11	12	12.7	14	80	100	85	3	M6x15	23	30			

LCK 070P

FM

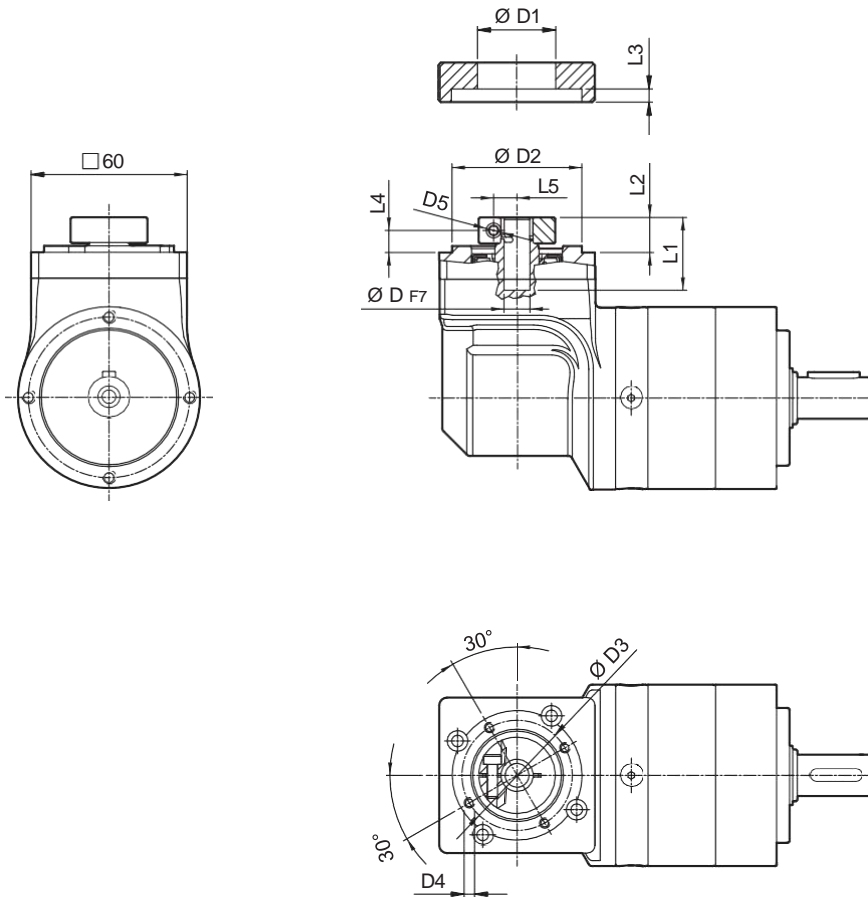

D	D		D1	D2	D3	D4	D5	L1	L2	L3	L4	L5
	6	7										
6	6.35	7	32.5	50	42.5	M4x8	M4	28	13.5	3	8.5	8
8	9	9.52	32.5	50	42.5	M4x8	M4	28	13.5	3	8.5	9
11	12	12.7	35.5	50	42.5	M4x8	M4	23	13.5	3	8.5	11
14			35.5	50	42.5	M4x8	M4	25	15.5	3	8.9	11.5

	i	M_{n2}	M_{a2}	M_{p2}	n_1	n_{1max}	ϕ_s	C_t	R_{2max}	A_{2max}	η	J_G [kgcm ²]	
		[Nm]	[Nm]	[Nm]	[min ⁻¹]	[min ⁻¹]	[arcmin]	$\frac{Nm}{arcmin}$	[N]	[N]	%	D	D
LCK 070P 2_6		25	38	45	2500	5000	6'	2.8	1300	1400	94	6 ... 9.52	11 ... 14
LCK 070P 2_8		30	40	60	2500	5000	6'	2.8	1300	1400	94	0.25	0.26
LCK 070P 2_10		28	40	70	2500	5000	6'	2.8	1300	1400	94	0.24	0.25
LCK 070P 2_14		28	40	70	2500	5000	6'	2.8	1300	1400	94	0.23	0.24
LCK 070P 2_20		28	39	60	2500	5000	6'	2.8	1300	1400	94	0.23	0.24
LCK 070P 3_24		29	45	70	2500	5000	8'	2.5	1300	1400	91	0.24	0.26
LCK 070P 3_30		29	45	70	2500	5000	8'	2.5	1300	1400	91	0.24	0.26
LCK 070P 3_50		30	45	70	2500	5000	8'	2.5	1300	1400	91	0.23	0.24
LCK 070P 3_70		30	45	70	2500	5000	8'	2.5	1300	1400	91	0.23	0.24
LCK 070P 3_80		30	45	70	2500	5000	8'	2.5	1300	1400	91	0.23	0.24
LCK 070P 3_100		30	45	70	2500	5000	8'	2.5	1300	1400	91	0.23	0.24

LCK

Please contact us for different motor adapters and input shaft bore.

LCK 090P

40B1 ... 110B1

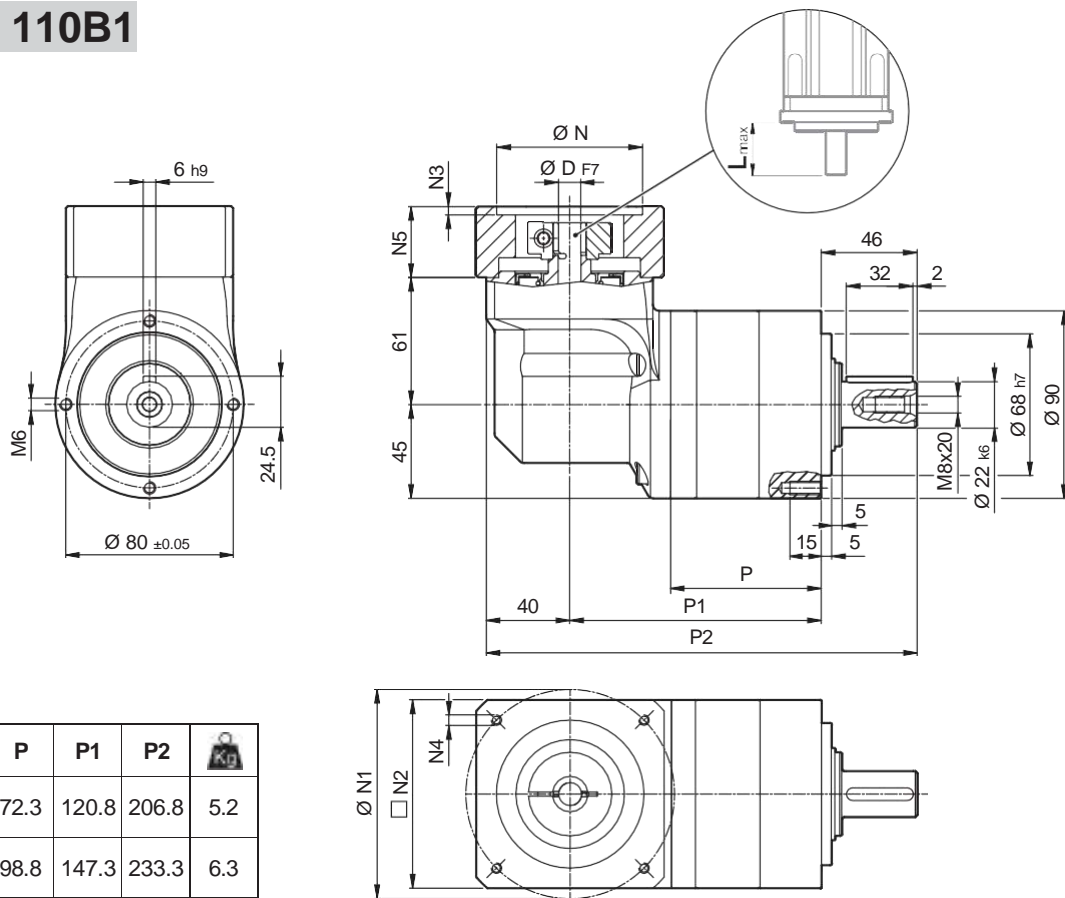

	P	P1	P2	
LCK 090P 2	72.3	120.8	206.8	5.2
LCK 090P 3	98.8	147.3	233.3	6.3

LCK

												N	N1	N2	N3	N4	N5	L _{max}	
	8	9	9.52	11	12	12.7	14	-	-	-	-								
40B1	8	9	9.52	11	12	12.7	14	-	-	-	-	40	63	80	4	M4x10	34	40	
45A	8	9	9.52	11	12	12.7	-	-	-	-	-	45	63	80	4	M4x10	34	40	
50B1	8	9	9.52	11	12	12.7	14	-	-	-	-	50	65	80	4	M5x16	34	40	
50BH1	8	9	9.52	11	12	12.7	14	-	-	-	-	50	65	80	4	5.5	34	40	
50C1	8	9	9.52	11	12	12.7	14	-	-	-	-	50	70	80	4	M4x10	34	40	
50D	8	9	9.52	11	12	12.7	14	-	-	-	-	50	95	80	4	M6x10	34	40	
55A	8	9	9.52	11	12	12.7	14	15.875	16	17	19	19.05	55.5	125.7	105	4	M6x16	34	40
60A2	8	9	9.52	11	12	12.7	14	-	-	-	-	60	75	80	4	M5x16	34	40	
60AH2	8	9	9.52	11	12	12.7	14	-	-	-	-	60	75	90	4	5.5	34	40	
60B1	8	9	9.52	11	12	12.7	14	15.875	16	-	-	60	85	80	4	M5x16	34	40	
60C1	8	9	9.52	11	12	12.7	14	15.875	16	-	-	60	90	80	4	M5x16	34	40	
70A1	8	9	9.52	11	12	12.7	14	15.875	16	17	19	19.05	70	85	80	4	M6x20	34	40
70AH1	8	9	9.52	11	12	12.7	14	15.875	16	17	19	19.05	70	85	90	4	6.5	34	40
70B1	8	9	9.52	11	12	12.7	14	15.875	16	17	19	19.05	70	90	80	4	M5x16	34	40
73A1	8	9	9.52	11	12	12.7	14	-	-	-	-	73	98.4	85	4	M5x16	34	40	
80A1	8	9	9.52	11	12	12.7	14	15.875	16	17	19	19.05	80	100	90	4	M6x16	34	40
95A	8	9	9.52	11	12	12.7	14	15.875	16	17	19	19.05	95	115	100	4	M8x20	34	40
95B	8	9	9.52	11	12	12.7	14	15.875	16	17	19	19.05	95	130	115	4	M8x20	34	40
110A	8	9	9.52	11	12	12.7	14	15.875	16	17	19	19.05	110	130	115	4	M8x20	34	40
110B	8	9	9.52	11	12	12.7	14	15.875	16	17	19	19.05	110	145	120	6.5	M8x20	44	50
110B1	8	9	9.52	11	12	12.7	14	15.875	16	17	19	19.05	110	145	120	6.5	M8x20	54	60

LCK 090P

FM

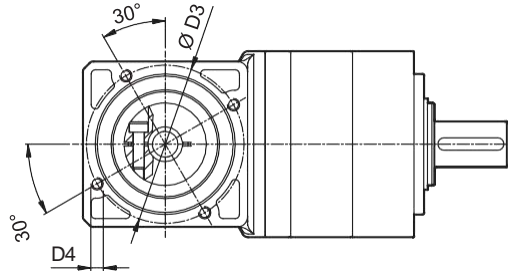
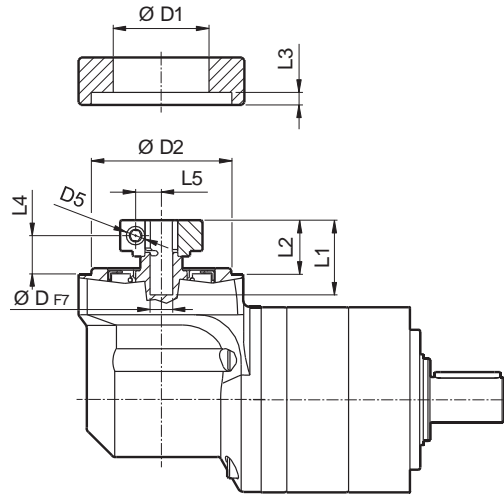
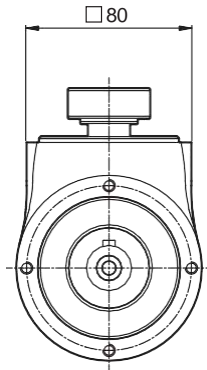

			D1	D2	D3	D4	D5	L1	L2	L3	L4	L5
8	9	9.52	38	68	76.5	M6x10	M6	36.3	26.3	9.5	18.8	10.5
11	12	12.7	43	68	76.5	M6x10	M6	36.3	26.3	9.5	18.8	12.5
14	15.875	16	48	68	76.5	M6x10	M6	36.3	26.3	9.5	18.8	14.5
19	19.05		51	68	76.5	M6x10	M6	36.3	26.3	9.5	18.8	16.5

	M_{n2} [Nm]	M_{a2} [Nm]	M_{p2} [Nm]	n_1 [min ⁻¹]	n_{1max} [min ⁻¹]	ϕ_s [arcmin]	C_t [Nm/arcmin]	R_{2max} [N]	A_{2max} [N]	η %	J_G [kgcm ²]	
											$8 \dots 12.7$	$14 \dots 19$
LCK 090P 2_6	45	70	90	2500	5000	6'	11	2200	1900	94	0.85	1.03
LCK 090P 2_8	60	90	120	2500	5000	6'	11	2200	1900	94	0.79	0.98
LCK 090P 2_10	50	90	150	2500	5000	6'	8	2200	1900	94	0.77	0.96
LCK 090P 2_14	50	90	160	2500	5000	6'	8	2200	1900	94	0.75	0.94
LCK 090P 2_20	40	75	150	2500	5000	6'	8	2200	1900	94	0.74	0.93
LCK 090P 3_24	60	90	160	2500	5000	8'	10.8	2200	1900	91	0.81	1.00
LCK 090P 3_30	60	90	160	2500	5000	8'	10.8	2200	1900	91	0.81	1.00
LCK 090P 3_50	50	90	160	2500	5000	8'	7.8	2200	1900	91	0.76	0.94
LCK 090P 3_70	50	90	160	2500	5000	8'	7.8	2200	1900	91	0.74	0.93
LCK 090P 3_80	60	90	160	2500	5000	8'	10.8	2200	1900	91	0.74	0.93
LCK 090P 3_100	50	90	160	2500	5000	8'	7.8	2200	1900	91	0.74	0.93

Please contact us for different motor adapters and input shaft bore.

LCK 120P

50D ... 130A1

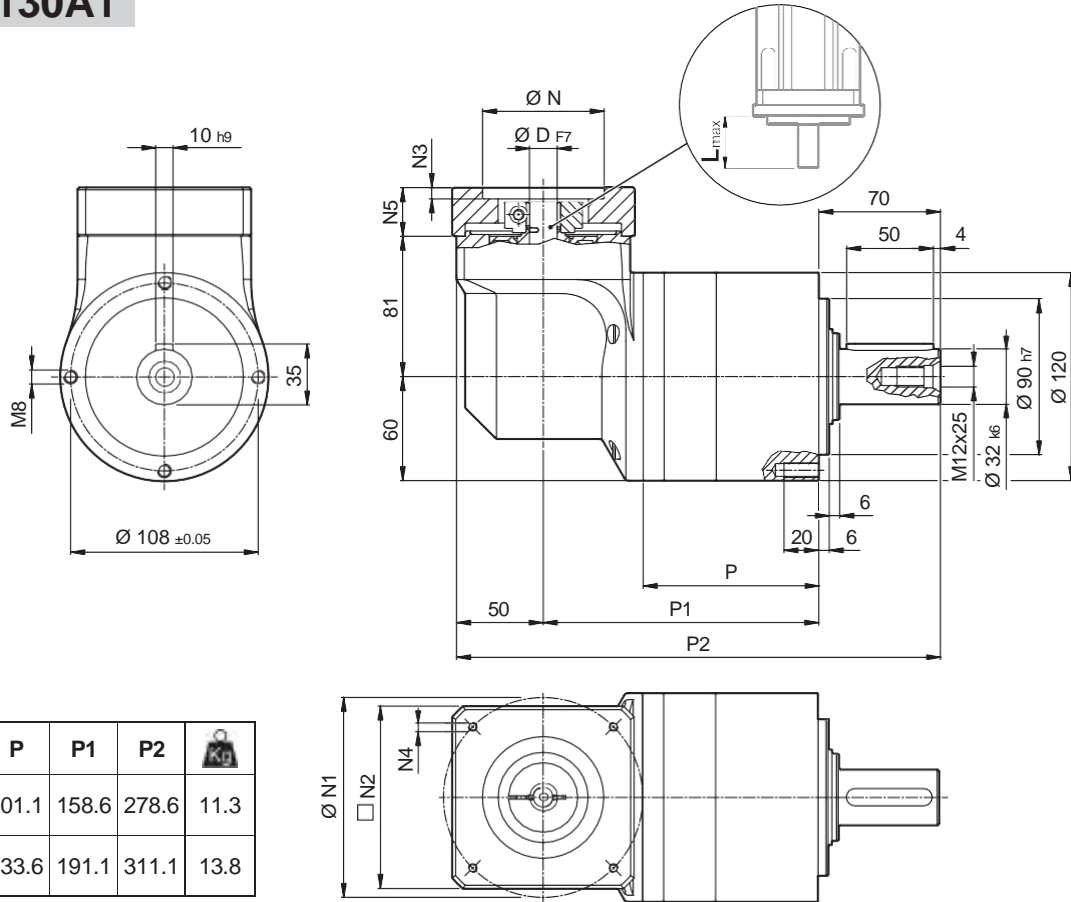

	P	P1	P2	
LCK 120P 2	101.1	158.6	278.6	11.3
LCK 120P 3	133.6	191.1	311.1	13.8

LCK

											N	N1	N2	N3	N4	N5	L _{max}
50D	11	12	12.7	14	15	15.875	16	19	-	-	50	95	100	5	M6x14	28	40
55A	11	12	12.7	14	15	15.875	16	19	-	-	55.5	125.7	105	5	M6x16	28	40
60A2	11	12	12.7	14	15	15.875	16	19	-	-	60	75	100	5	M5x14	28	40
60AH2	11	12	12.7	14	15	15.875	16	19	-	-	60	75	100	5	6.5	33	40
60B1	11	12	12.7	14	15	15.875	16	19	-	-	60	85	100	6.5	M5x14	28	40
70A1	11	12	12.7	14	15	15.875	16	19	-	-	70	85	100	5	M6x14	28	40
70AH1	11	12	12.7	14	15	15.875	16	19	-	-	70	85	100	5	6	33	40
70B1	11	12	12.7	14	15	15.875	16	19	-	-	70	90	100	6.5	M5x12	28	40
80A1	11	12	12.7	14	15	15.875	16	19	-	-	80	100	100	5	M6x16	28	40
80AH1	11	12	12.7	14	15	15.875	16	19	-	-	80	100	100	5	6.5	28	40
95A	11	12	12.7	14	15	15.875	16	19	-	-	95	115	100	5	M8x18	28	40
95A1	11	12	12.7	14	15	15.875	16	19	22	24	95	115	100	5	M8x18	38	50
95B	11	12	12.7	14	15	15.875	16	19	-	-	95	130	115	5	M8x18	28	40
110A	11	12	12.7	14	15	15.875	16	19	-	-	110	130	115	5	M8x18	28	40
110A1	11	12	12.7	14	15	15.875	16	19	22	24	110	130	115	6.5	M8x20	38	50
110B	11	12	12.7	14	15	15.875	16	19	22	24	110	145	120	6.5	M8x20	38	50
110B1	11	12	12.7	14	15	15.875	16	19	22	24	110	145	120	6.5	M8x20	48	60
130A	11	12	12.7	14	15	15.875	16	19	22	24	130	165	140	6.5	M10x20	38	50
130A1	11	12	12.7	14	15	15.875	16	19	22	24	130	165	140	6.5	M10x25	48	60

LCK 120P

FM

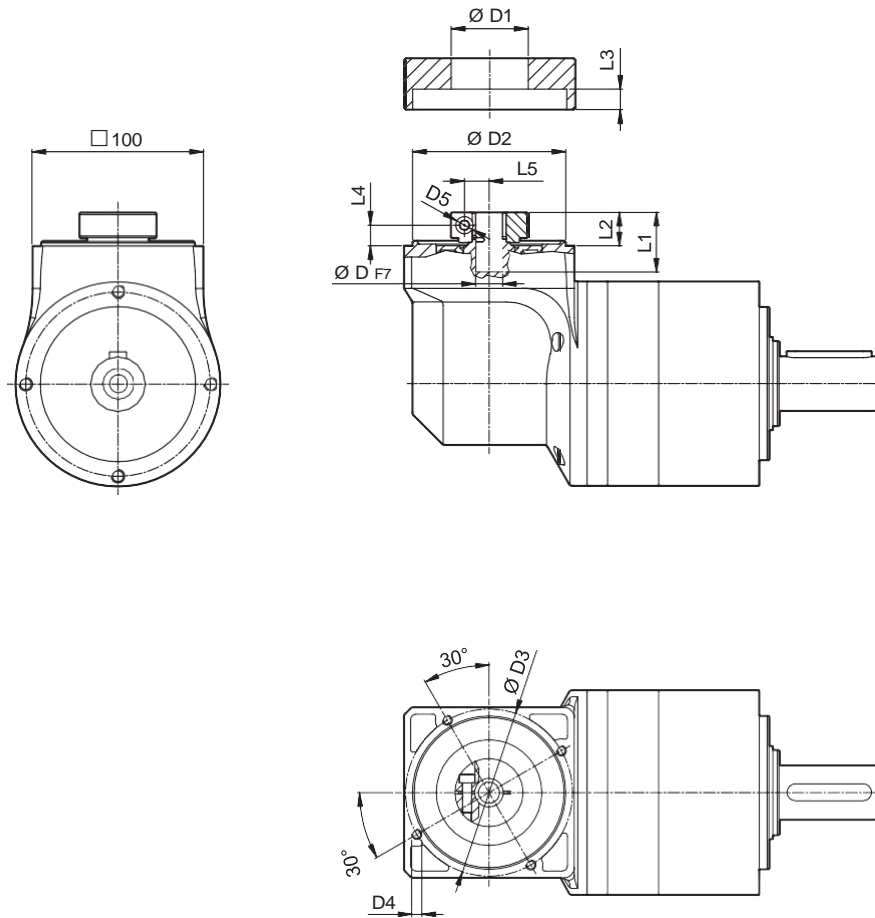

				D1	D2	D3	D4	D5	L1	L2	L3	L4	L5
11	12	12.7		43	90	98	M6x15	M6	35	19.5	7.6	12.1	12.5
14	15	15.875	16	48	90	98	M6x15	M6	35	19.5	7.6	12.1	14.5
19				51	90	98	M6x15	M6	35	19.5	7.6	12.1	16.5
22	24			56.5	90	98	M6x15	M6	37	21.5	7.6	12.1	19

	i	M _{n2} [Nm]	M _{a2} [Nm]	M _{p2} [Nm]	n ₁ [min ⁻¹]	n _{1 max} [min ⁻¹]	φ _s [arcmin]	C _t $\frac{Nm}{arcmin}$	R _{2 max} [N]	A _{2 max} [N]	η %	J _G [kgcm ²]		
													14 ... 19	22 ; 24
LCK 120P 2_6		110	160	225	2000	4500	6'	28.4	3500	3000	94	1.74	1.82	2.01
LCK 120P 2_8		140	220	300	2000	4500	6'	28.4	3500	3000	94	1.52	1.60	1.79
LCK 120P 2_10		125	220	360	2000	4500	6'	28.4	3500	3000	94	1.44	1.52	1.71
LCK 120P 2_14		125	220	360	2000	4500	6'	28.4	3500	3000	94	1.37	1.45	1.63
LCK 120P 2_20		100	165	300	2000	4500	6'	28.4	3500	3000	94	1.32	1.40	1.59
LCK 120P 3_24		155	220	360	2000	4500	8'	28.4	3500	3000	91	1.64	1.72	1.90
LCK 120P 3_30		155	220	360	2000	4500	8'	28.4	3500	3000	91	1.63	1.71	1.89
LCK 120P 3_50		125	220	360	2000	4500	8'	22.9	3500	3000	91	1.40	1.48	1.67
LCK 120P 3_70		125	220	360	2000	4500	8'	22.9	3500	3000	91	1.34	1.42	1.61
LCK 120P 3_80		155	220	360	2000	4500	8'	28.4	3500	3000	91	1.31	1.39	1.58
LCK 120P 3_100		125	220	360	2000	4500	8'	22.9	3500	3000	91	1.31	1.39	1.58

LCK

Please contact us for different motor adapters and input shaft bore.



MPE Series

The MPE series offers a cost-effective solution for applications that require medium levels of positioning accuracy. It offers high flexibility in terms of sizes, ratios and mounting configurations for a variety of applications requirements. The output design in line with market standards ensures great compatibility for easy retrofits and a high level of freedom in projects development.

Main benefits

- Great price-performance ratio
- High compatibility for easy retrofits
- Suitable for a variety of applications thanks to great flexibility

Main features

- Nominal output torque (Nm)

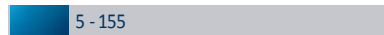

- Torsional backlash (arcmin)



- Torsional stiffness (Nm/arcmin)

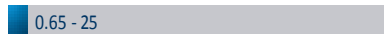

- Max tilting moment (Nm)



Protection class

- IP54

Frame sizes

- 040
- 060
- 080
- 120

Main options

- Input versions

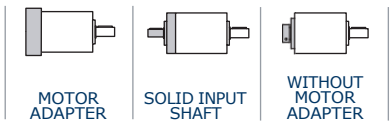

- Output shafts versions

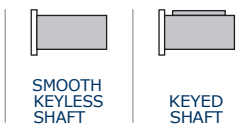

- Lubrication



12 FEATURES OF MPE SERIES

The MPE Series satisfies a wide range of applications requirements thanks to its high flexibility in terms of sizes, ratios and mounting configurations.

Its proportioned design allows quiet running and provides a long service life without maintenance requirements.

Motor mounting is an operation that can be easily conducted without the need of any particular tooling, other than that usually available in a normally equipped workshop.

- Available with either standard (STD) or reduced (LOW) backlash*:
 1-stage units: standard $\phi_S \leq 10'$; reduced $\phi_R \leq 5'$
 2-stage units: standard $\phi_S \leq 12'$; reduced $\phi_R \leq 7'$
- Input section oil seals made from a Fluoroelastomer compound are supplied as standard*.
- Noise pressure level $LP \leq 70$ dB(A). Conditions: distance 1 m; measured without load an input speed of $n_1 = 3000 \text{ min}^{-1}$; $i=10$.
- Units are factory packed with synthetic grease to NLGI consistency class 00*, in the absence of contamination the lubricant requires no periodical changes.
- Ambient temperature min -20°C , max $+30^\circ\text{C}$. For temperature higher than 30°C please consider derating factor f_T .
- Housing temperature must not exceed $T_{\text{max}} = 90^\circ\text{C}$.

		Distribution of nominal torque M_{n2} [Nm]																	
	[i]	3	4	5	7	9	10	12	15	16	20	25	28	30	35	40	50	70	100
MPE 040		12	12	12	8	12	5	12	12	12	12	12	12	12	12	12	12	8	5
MPE 060		29	30	25	25	29	18	29	29	30	30	30	30	29	30	30	30	30	18
MPE 080		65	60	50	50	65	40	65	65	60	60	50	50	65	50	60	50	50	40
MPE 120		155	155	125	125	155	100	155	155	155	155	125	125	155	125	155	125	125	100

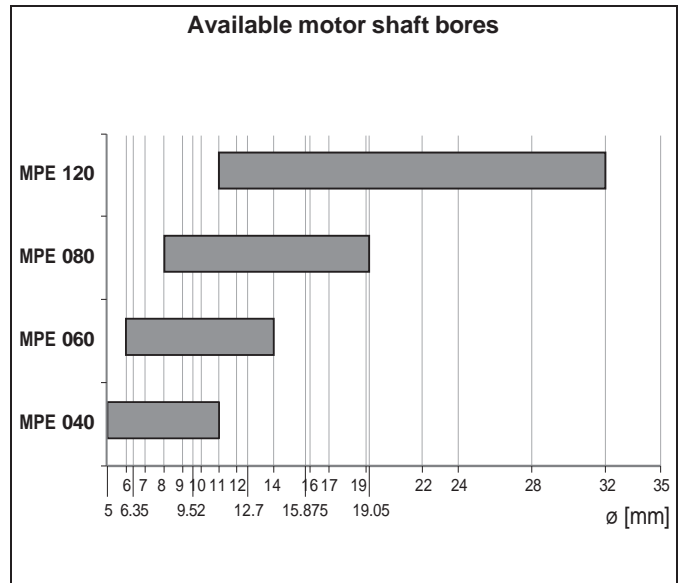
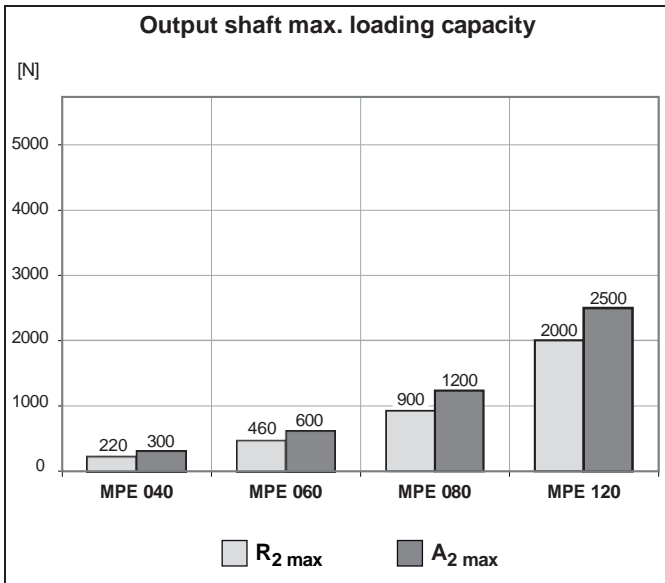

* not available for size 040

12.1 ORDERING CODE

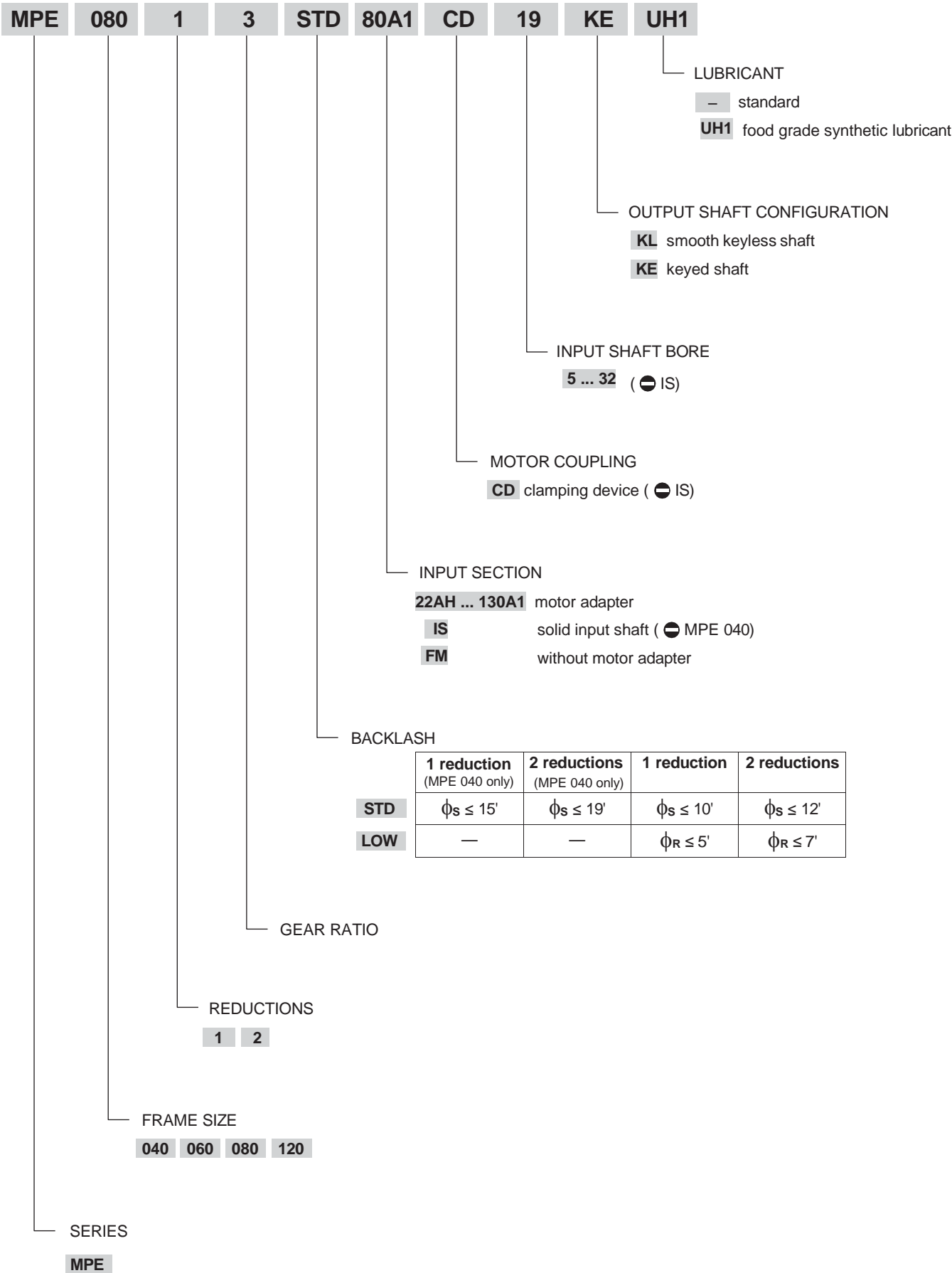

MPE

12.2 DIMENSIONS AND TECHNICAL SPECIFICATIONS

MPE 040

22AH ... 50C0

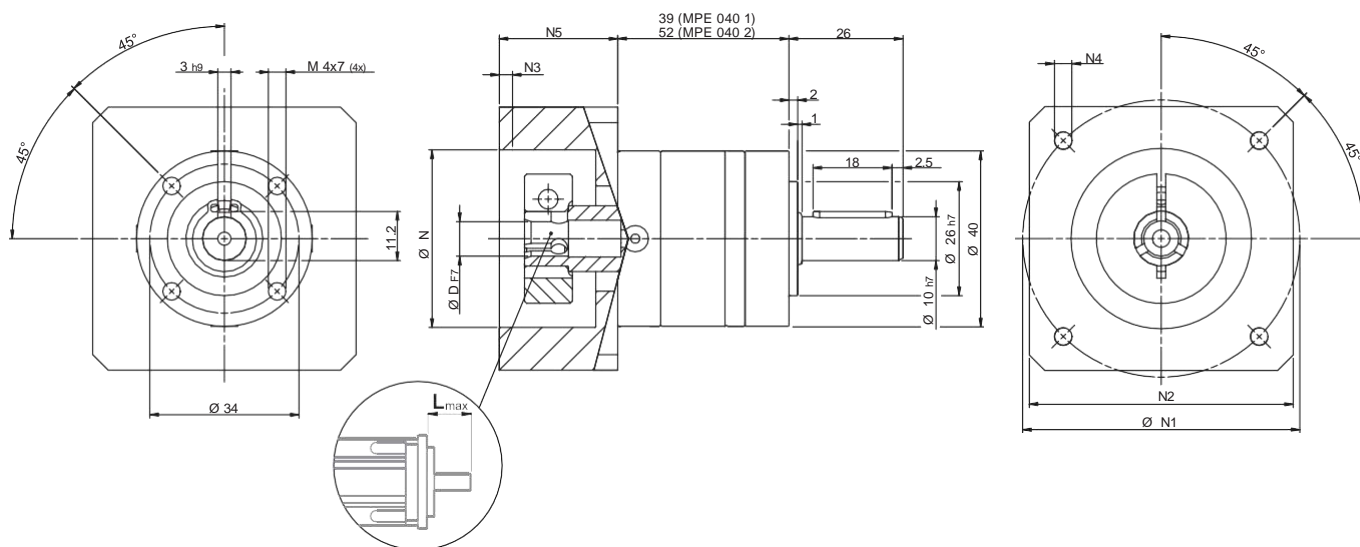

MPE 040 1	0.5
MPE 040 2	0.8

						N	N1	N2	N3	N4	N5	L _{max}
22AH	5	6.35	-	-	-	22	43.84	42	6	3.5	20	22
30A0	-	-	8	9	-	30	46	50	4	M4x12	27	26
30B0	-	-	8	9	-	30	45	50	4	M3x8	27	26
36A	5	6.35	-	-	-	36	57.98	60	10	M4x12	30	32
38B	5	6.35	-	-	-	38.1	66.66	60	10	M4x12	25	26
40B	-	-	8	9	11	40	63	60	4	M4x12	27	26
50C0	-	-	8	9	11	50	70	60	4	M4x12	27	26

Please contact us for other motor adapters and input shaft bore.

MPE 040

FM

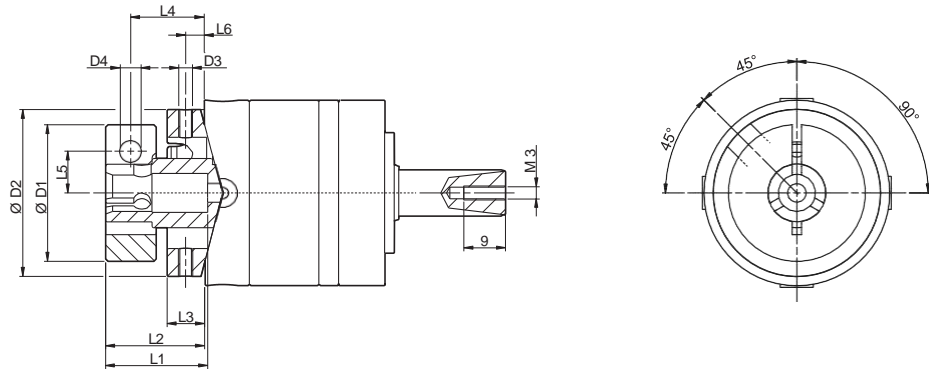

					D1	D2	D3	D4	L1	L2	L3	L4	L5	L6
5	6.35	—	—	—	22	36	M3x5	M5	15.5	11.2	10	6.25	—	4
—	—	8	9	—	32	36	M3x5	M4	21.5	21	10	15.85	9	4
—	—	—	—	11	36	36	M3x5	M4	21.5	21	10	16.25	11	4

 i	M _{n 2}	M _{a 2}	M _{p 2}	n _{1N}	n _{1 max}	ϕ _s	C _t	R _{2 max}	A _{2 max}	η	J _G [kgcm ²]	
	[Nm]	[Nm]	[Nm]	[rpm]	[rpm]	[arcmin]	$\frac{Nm}{arcmin}$	[N]	[N]	%	 5 ... 6.35	8 ... 11
MPE 040 1_3	12	15	21	3500	5000	15'	0.8	220	300	97	0.05	0.09
MPE 040 1_4	12	15	21	3500	5000	15'	0.8	220	300	97	0.04	0.08
MPE 040 1_5	12	15	21	3500	5000	15'	0.8	220	300	97	0.03	0.07
MPE 040 1_7	8	10	14	3500	5000	15'	0.8	220	300	97	0.03	0.07
MPE 040 1_10	5	8	12	3500	5000	15'	0.8	220	300	97	0.02	0.06
MPE 040 2_9	12	15	21	3500	5000	19'	0.65	220	300	94	0.05	0.09
MPE 040 2_12	12	15	21	3500	5000	19'	0.65	220	300	94	0.05	0.09
MPE 040 2_15	12	15	21	3500	5000	19'	0.65	220	300	94	0.04	0.08
MPE 040 2_16	12	15	21	3500	5000	19'	0.65	220	300	94	0.04	0.08
MPE 040 2_20	12	15	21	3500	5000	19'	0.65	220	300	94	0.04	0.08
MPE 040 2_25	12	15	21	3500	5000	19'	0.65	220	300	94	0.04	0.08
MPE 040 2_28	12	15	21	3500	5000	19'	0.65	220	300	94	0.04	0.07
MPE 040 2_30	12	15	21	3500	5000	19'	0.65	220	300	94	0.03	0.07
MPE 040 2_35	12	15	21	3500	5000	19'	0.65	220	300	94	0.03	0.06
MPE 040 2_40	12	15	21	3500	5000	19'	0.65	220	300	94	0.03	0.06
MPE 040 2_50	12	15	21	3500	5000	19'	0.65	220	300	94	0.02	0.06
MPE 040 2_70	8	10	14	3500	5000	19'	0.65	220	300	94	0.02	0.06
MPE 040 2_100	5	8	12	3500	5000	19'	0.65	220	300	94	0.02	0.06

MPE

MPE 060

25AH ... 80A

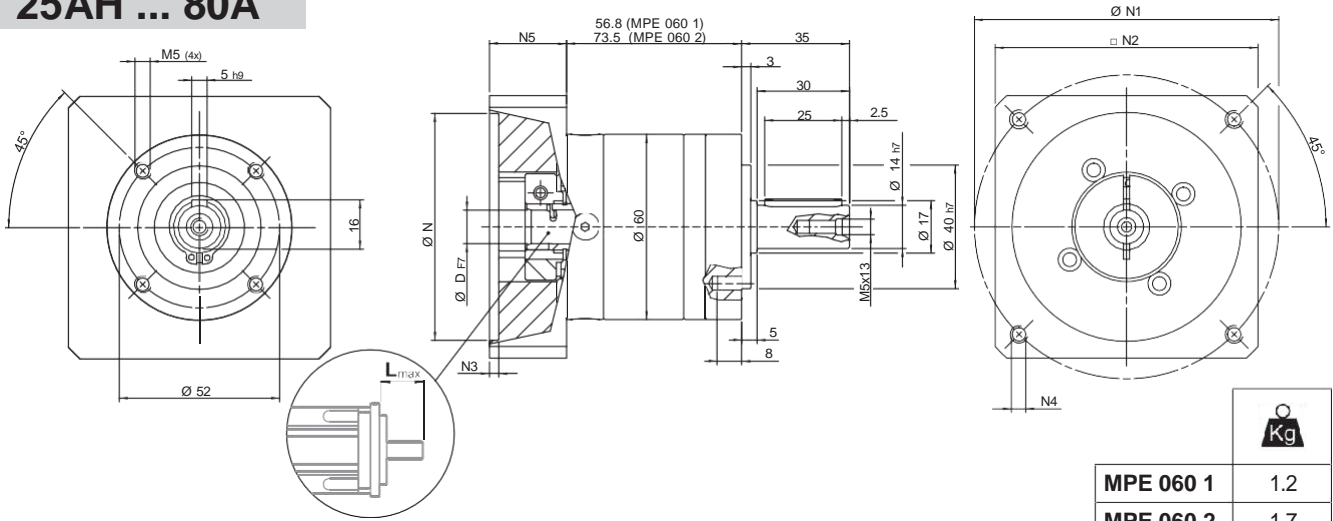

IS

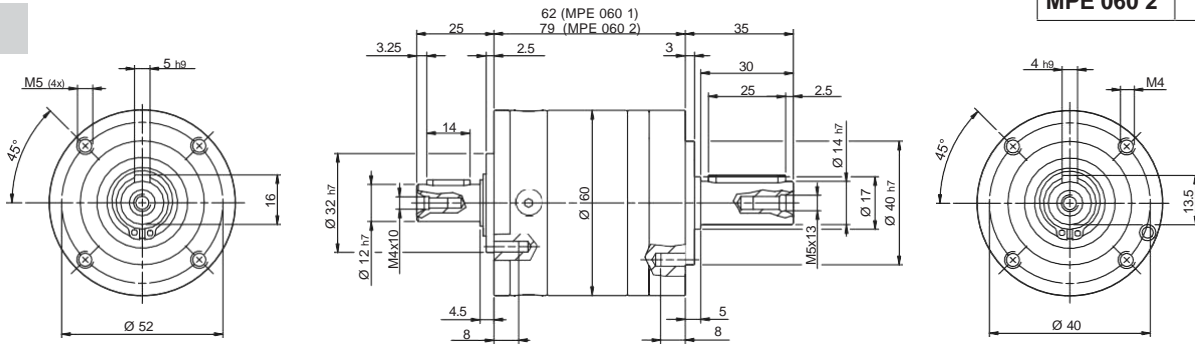

	D	N	N1		N2	N3	N4	N5	L _{max}
			min	max					
25AH	6 6.35 7 8 9 9.52 - - - - -	25	39	56					
26AH	6 6.35 7 8 9 9.52 - - - - -	26	39	56					
28AH	6 6.35 7 8 9 9.52 - - - - -	28	39	56					
30AH	6 6.35 7 8 9 9.52 - - - - -	30	39	56					
32AH	6 6.35 7 8 9 9.52 - - - - -	32	39	56					
34AH	6 6.35 7 8 9 9.52 - - - - -	34	40	56	65	3.5	4.5	25	25
36AH	6 6.35 7 8 9 9.52 - - - - -	36	42	56					
39AH	6 6.35 7 8 9 9.52 - - - - -	39	45	56					
40AH	6 6.35 7 8 9 9.52 - - - - -	40	46	56					
38B	6 6.35 7 8 9 9.52 10 11 12 12.7 -	38.1	66.6	60	3	M4x10	18	25	
40B	6 6.35 7 8 9 9.52 10 11 12 12.7 -	40	63	60	3	M4x10	18	25	
50A	6 6.35 7 8 9 9.52 10 11 12 12.7 -	50	60	60	3	M4x10	18	25	
50B	6 6.35 7 8 9 9.52 10 11 12 12.7 14	50	65	60	3	M5x12	23	30	
50BH	6 6.35 7 8 9 9.52 10 11 12 12.7 14	50	65	65	3	5.5	25	32	
50C	6 6.35 7 8 9 9.52 10 11 12 12.7 14	50	70	60	3	M4x10	23	30	
55MH	6 6.35 7 8 9 9.52 10 11 12 12.7 -	55	80	65	2	5.5	16	23	
60A	6 6.35 7 8 9 9.52 10 11 12 12.7 -	60	75	65	3	M5x12	18	25	
60AH	6 6.35 7 8 9 9.52 10 11 12 12.7 -	60	75	65	3	5.5	18	25	
60A1	6 6.35 7 8 9 9.52 10 11 12 12.7 14	60	75	65	3	M5x12	23	30	
60AH1	6 6.35 7 8 9 9.52 10 11 12 12.7 14	60	75	65	3	5.5	23	30	
60B	6 6.35 7 8 9 9.52 10 11 12 12.7 14	60	85	75	3	M5x12	23	30	
60C	6 6.35 7 8 9 9.52 10 11 12 12.7 14	60	90	75	3	M5x12	23	30	
70A	6 6.35 7 8 9 9.52 10 11 12 12.7 14	70	85	75	3	M6x15	23	30	
70B	6 6.35 7 8 9 9.52 10 11 12 12.7 14	70	90	75	3	M5x12	23	30	
73A	6 6.35 7 8 9 9.52 10 11 12 12.7 14	73	98.4	85	3	M5x12	25	32	
80A	6 6.35 7 8 9 9.52 10 11 12 12.7 14	80	100	85	3	M6x15	23	30	

Please contact us for other motor adapters and input shaft bore.

MPE 060

FM

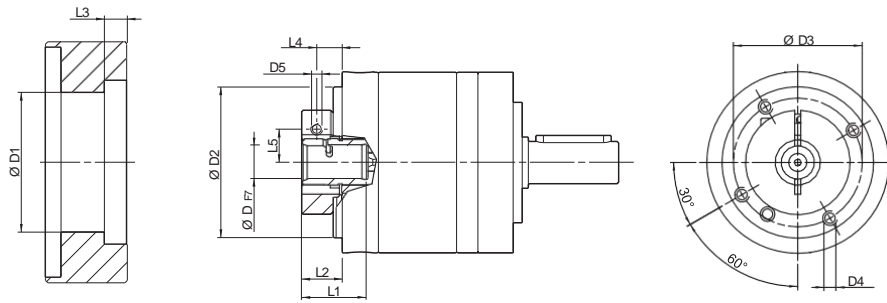

				D1	D2	D3	D4	D5	L1	L2	L3	L4	L5
6	6.35	7		32.5	50	42.5	M4x8	M4	21.7	13.2	3	8.2	8
8	9	9.52	10	32.5	50	42.5	M4x8	M4	21.7	13.2	3	8.2	9
11	12	12.7		35.5	50	42.5	M4x8	M4	22	13.5	3	8.5	11
14				35.5	50	42.5	M4x8	M4	25	17	3	10.2	11.5

	M_{n2} [Nm]	M_{a2} [Nm]	M_{p2} [Nm]	n_1 [rpm]	n_{1max} [rpm]	ϕ_S [arcmin]	ϕ_R [arcmin]	C_t $\frac{Nm}{arcmin}$	R_{1max} [N]	R_{2max} [N]	A_{2max} [N]	η %	J_G [kgcm ²]	
													6 ... 10	11 ... 14
MPE 060 1_3	29	55	60	3300	4000	10'	5'	3	200	460	600	97	0.12	0.14
MPE 060 1_4	30	45	70	3500	5000	10'	5'	3	200	460	600	97	0.08	0.10
MPE 060 1_5	25	40	70	3500	5000	10'	5'	3	200	460	600	97	0.06	0.09
MPE 060 1_7	25	40	70	4000	5000	10'	5'	3	200	460	600	97	0.05	0.07
MPE 060 1_10	18	30	60	4000	6000	10'	5'	3	200	460	600	97	0.04	0.06
MPE 060 2_9	29	55	60	3300	4000	12'	7'	2.5	200	460	600	94	0.11	0.13
MPE 060 2_12	29	55	70	3300	4000	12'	7'	2.5	200	460	600	94	0.10	0.13
MPE 060 2_15	29	55	70	3300	4000	12'	7'	2.5	200	460	600	94	0.10	0.12
MPE 060 2_16	30	45	70	3500	5000	12'	7'	2.5	200	460	600	94	0.07	0.09
MPE 060 2_20	30	45	70	3500	5000	12'	7'	2.5	200	460	600	94	0.06	0.08
MPE 060 2_25	30	45	70	3500	5000	12'	7'	2.5	200	460	600	94	0.06	0.08
MPE 060 2_28	30	45	70	4000	6000	12'	7'	2.5	200	460	600	94	0.05	0.07
MPE 060 2_30	29	55	60	4000	6000	12'	7'	2.5	200	460	600	94	0.05	0.06
MPE 060 2_35	30	45	70	4000	6000	12'	7'	2.5	200	460	600	94	0.05	0.07
MPE 060 2_40	30	45	70	4000	6000	12'	7'	2.5	200	460	600	94	0.04	0.06
MPE 060 2_50	30	45	70	4000	6000	12'	7'	2.5	200	460	600	94	0.04	0.06
MPE 060 2_70	30	45	70	4000	6000	12'	7'	2.5	200	460	600	94	0.04	0.06
MPE 060 2_100	18	30	60	4000	6000	12'	7'	2.5	200	460	600	94	0.04	0.06

MPE

MPE 080

40B1 ... 110B1

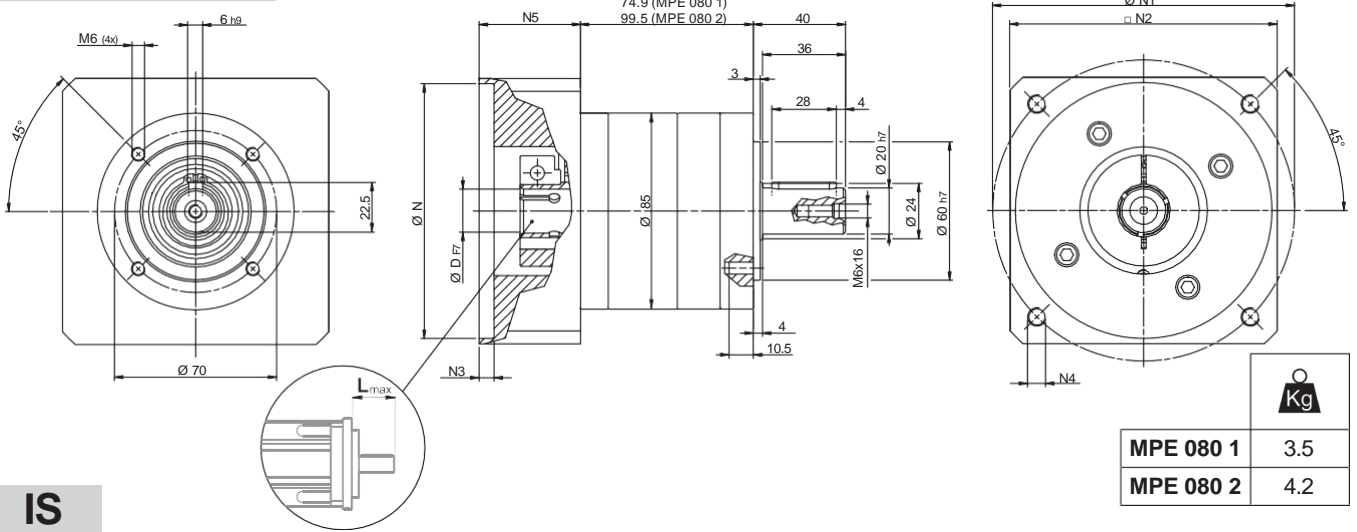

IS

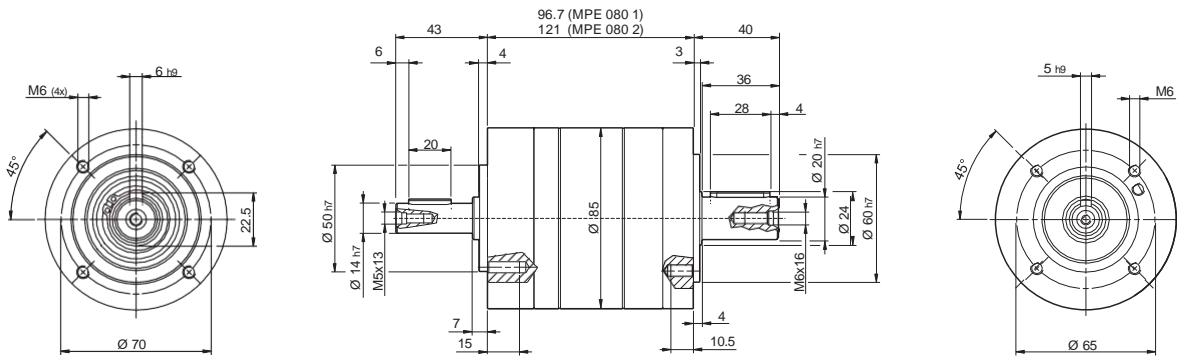

												N	N1	N2	N3	N4	N5	L _{max}	
40B1	8	9	9.52	11	12	12.7	14	-	-	-	-	40	63	80	4	M4x12	34	40	
45A	8	9	9.52	11	12	12.7	-	-	-	-	-	45	63	80	4	M4x12	34	40	
50B1	8	9	9.52	11	12	12.7	14	-	-	-	-	50	65	80	4	M5x16	34	40	
50BH1	8	9	9.52	11	12	12.7	14	-	-	-	-	50	65	80	4	5.5	34	40	
50C1	8	9	9.52	11	12	12.7	14	-	-	-	-	50	70	80	4	M4x10	34	40	
50D	8	9	9.52	11	12	12.7	14	-	-	-	-	50	95	80	4	M6x20	34	40	
55A	8	9	9.52	11	12	12.7	14	15.875	16	17	19	19.05	55.5	125.7	105	4	M6x20	34	40
60A2	8	9	9.52	11	12	12.7	14	-	-	-	-	60	75	80	4	M5x16	34	40	
60AH2	8	9	9.52	11	12	12.7	14	-	-	-	-	60	75	90	4	6.5	34	40	
60B1	8	9	9.52	11	12	12.7	14	15.875	16	-	-	60	85	80	4	M5x16	34	40	
60C1	8	9	9.52	11	12	12.7	14	15.875	16	-	-	60	90	80	4	M5x16	34	40	
70A1	8	9	9.52	11	12	12.7	14	15.875	16	17	19	19.05	70	85	80	4	M6x20	34	40
70AH1	8	9	9.52	11	12	12.7	14	15.875	16	17	19	19.05	70	85	90	4	6.5	34	40
70B1	8	9	9.52	11	12	12.7	14	15.875	16	17	19	19.05	70	90	80	4	M5x16	34	40
73A1	8	9	9.52	11	12	12.7	14	-	-	-	-	73	98.4	85	4	M5x16	34	40	
80A1	8	9	9.52	11	12	12.7	14	15.875	16	17	19	19.05	80	100	90	4	M6x16	34	40
95A	8	9	9.52	11	12	12.7	14	15.875	16	17	19	19.05	95	115	100	4	M8x20	34	40
95B	8	9	9.52	11	12	12.7	14	15.875	16	17	19	19.05	95	130	115	4	M8x20	34	40
110A	8	9	9.52	11	12	12.7	14	15.875	16	17	19	19.05	110	130	115	4	M8x20	34	40
110B	8	9	9.52	11	12	12.7	14	15.875	16	17	19	19.05	110	145	120	6.5	M8x20	44	50
110B1	8	9	9.52	11	12	12.7	14	15.875	16	17	19	19.05	110	145	120	6.5	M8x20	54	60

Please contact us for other motor adapters and input shaft bore.

MPE 080

FM

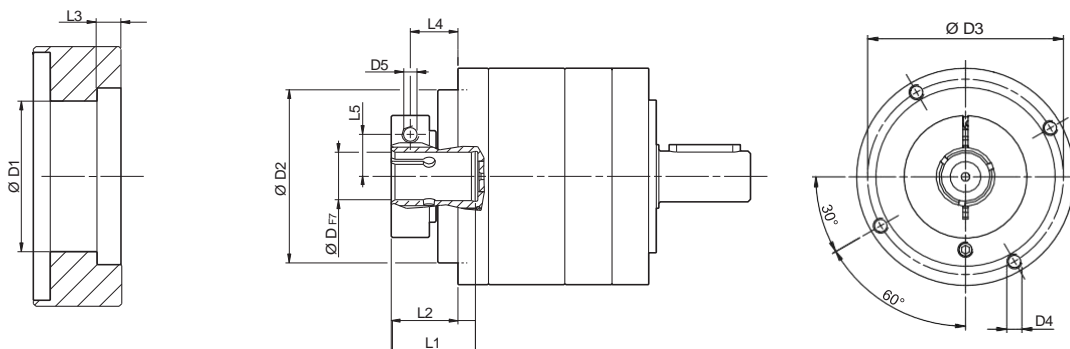

				D1	D2	D3	D4	D5	L1	L2	L3	L4	L5
8	9	9.52		38	68	76.5	M6x10	M6	34	26.8	9.5	18.8	10.5
11	12	12.7		43	68	76.5	M6x10	M6	34	26.8	9.5	18.8	12.5
14	15.875	16	17	48	68	76.5	M6x10	M6	34	26.8	9.5	18.8	14.5
19	19.05			51	68	76.5	M6x10	M6	34	26.8	9.5	18.8	16.5

	i	M _{n2} [Nm]	M _{a2} [Nm]	M _{p2} [Nm]	n ₁ [rpm]	n _{1 max} [rpm]	φ _S [arcmin]	φ _R [arcmin]	C _t Nm/arcmin	R _{1 max} [N]	R _{2 max} [N]	A _{2 max} [N]	η %	J _G [kgcm ²]	
														8 ... 12.7	14 ... 19.05
MPE 080 1_3		65	120	150	3500	4000	10'	5'	12	400	900	1200	97	0.50	0.59
MPE 080 1_4		60	110	160	3500	4000	10'	5'	12	400	900	1200	97	0.34	0.43
MPE 080 1_5		50	100	160	3200	4500	10'	5'	9	400	900	1200	97	0.28	0.37
MPE 080 1_7		50	100	160	4000	6000	10'	5'	9	400	900	1200	97	0.21	0.32
MPE 080 1_10		40	70	150	4000	6000	10'	5'	9	400	900	1200	97	0.20	0.29
MPE 080 2_9		65	120	150	3500	4000	12'	7'	12	400	900	1200	94	0.49	0.58
MPE 080 2_12		65	120	160	3500	4000	12'	7'	12	400	900	1200	94	0.47	0.56
MPE 080 2_15		65	120	160	3500	4000	12'	7'	12	400	900	1200	94	0.46	0.55
MPE 080 2_16		60	110	160	3500	4500	12'	7'	12	400	900	1200	94	0.32	0.41
MPE 080 2_20		60	110	160	3500	4500	12'	7'	12	400	900	1200	94	0.27	0.36
MPE 080 2_25		50	100	160	3200	4500	12'	7'	9	400	900	1200	94	0.27	0.36
MPE 080 2_28		50	100	160	4000	6000	12'	7'	9	400	900	1200	94	0.22	0.31
MPE 080 2_30		65	120	150	4000	6000	12'	7'	12	400	900	1200	94	0.20	0.29
MPE 080 2_35		50	100	160	4000	6000	12'	7'	9	400	900	1200	94	0.20	0.29
MPE 080 2_40		60	110	160	4000	6000	12'	7'	12	400	900	1200	94	0.20	0.29
MPE 080 2_50		50	100	160	4000	6000	12'	7'	9	400	900	1200	94	0.19	0.28
MPE 080 2_70		50	100	160	4000	6000	12'	7'	9	400	900	1200	94	0.19	0.28
MPE 080 2_100		40	70	150	4000	6000	12'	7'	9	400	900	1200	94	0.19	0.28

MPE

MPE 120

50D ... 130A1

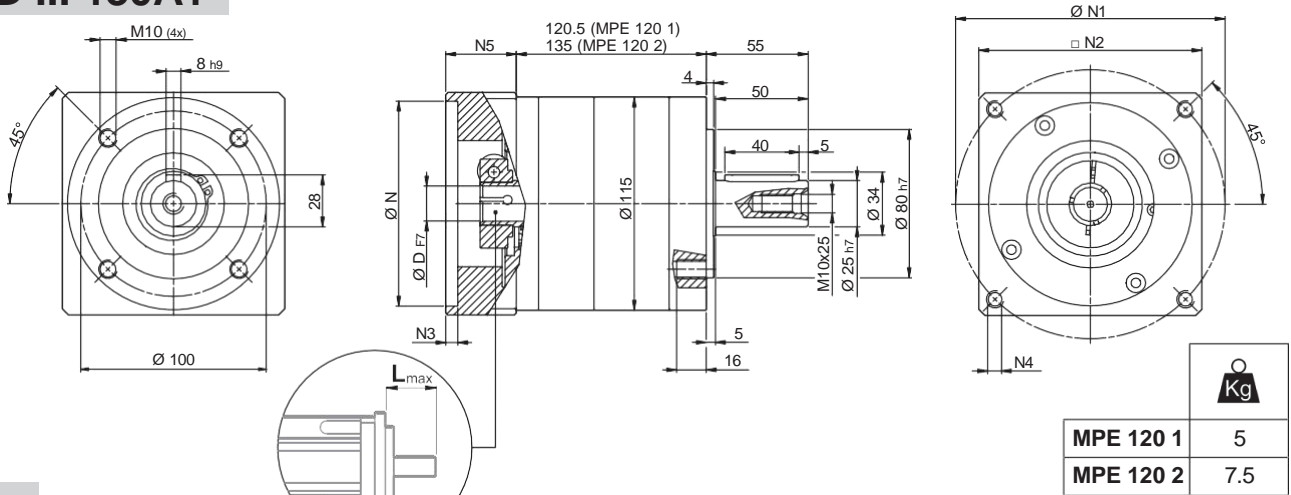

IS

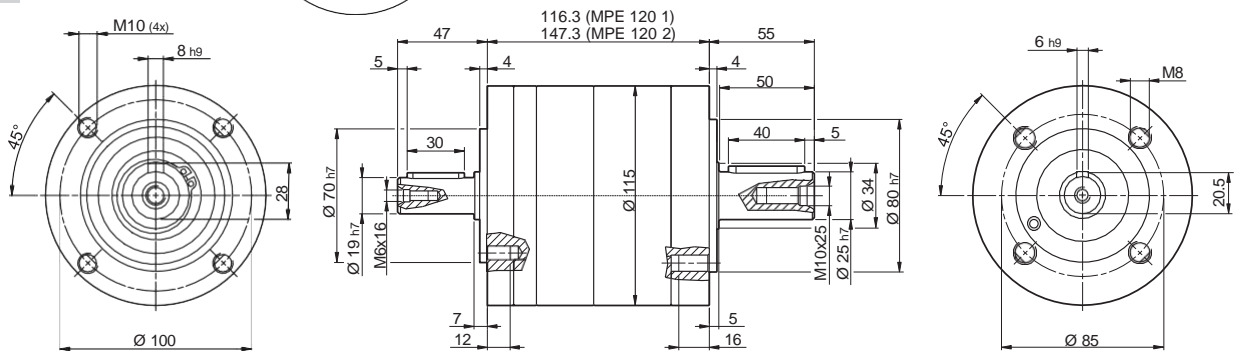

		D											N	N1	N2	N3	N4	N5	L _{max}	
50D		11	12	12.7	14	15	15.875	16	19	-	-	-	-	50	95	100	5	M6x14	28	40
55A		11	12	12.7	14	15	15.875	16	19	-	-	-	-	55	125.7	105	5	M6x16	28	40
60A2		11	12	12.7	14	15	15.875	16	19	-	-	-	-	60	75	100	6.5	M5x14	28	40
60AH2		11	12	12.7	14	15	15.875	16	19	-	-	-	-	60	75	100	4	6.5	33	40
60B1		11	12	12.7	14	15	15.875	16	19	-	-	-	-	60	85	100	6.5	M5x14	28	40
70A1		11	12	12.7	14	15	15.875	16	19	-	-	-	-	70	85	100	6.5	M6x14	28	40
70AH1		11	12	12.7	14	15	15.875	16	19	-	-	-	-	70	85	100	4	6.5	33	40
70B1		11	12	12.7	14	15	15.875	16	19	-	-	-	-	70	90	100	6.5	M5x12	28	40
80A1		11	12	12.7	14	15	15.875	16	19	-	-	-	-	80	100	100	6.5	M6x16	28	40
80AH1		11	12	12.7	14	15	15.875	16	19	-	-	-	-	80	100	100	4	6.5	33	40
95A		11	12	12.7	14	15	15.875	16	19	-	-	-	-	95	115	100	6.5	M8x18	28	40
95A1		11	12	12.7	14	15	15.875	16	19	22	24	-	-	95	115	100	6.5	M8x18	38	50
95B		11	12	12.7	14	15	15.875	16	19	-	-	-	-	95	130	115	6.5	M8x18	28	40
110A		11	12	12.7	14	15	15.875	16	19	-	-	-	-	110	130	115	6.5	M8x18	28	40
110A1		11	12	12.7	14	15	15.875	16	19	22	24	-	-	110	130	115	6.5	M8x20	38	50
110B		11	12	12.7	14	15	15.875	16	19	22	24	-	-	110	145	120	6.5	M8x20	38	50
110B1		11	12	12.7	14	15	15.875	16	19	22	24	28	-	110	145	120	6.5	M8x20	48	60
130A		11	12	12.7	14	15	15.875	16	19	22	24	-	-	130	165	140	6.5	M10x20	38	50
130A1		11	12	12.7	14	15	15.875	16	19	22	24	28	32	130	165	140	6.5	M10x25	48	60

Please contact us for other motor adapters and input shaft bore.

MPE 120

FM

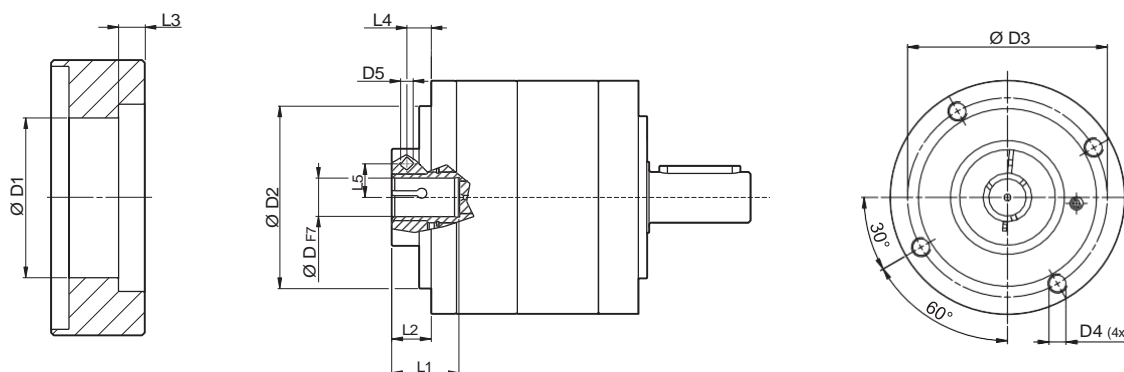

		D1	D2	D3	D4	D5	L1	L2	L3	L4	L5
11	12 12.7	43	90	98	M6x15	M6	33.5	20	7.6	12	12.5
14	15 15.875 16	48	90	98	M6x15	M6	33.5	20	7.6	12.5	14.5
19		51	90	98	M6x15	M6	33.5	23	7.6	12.5	16.5
22	24	56.5	90	98	M6x15	M6	36.5	23	7.6	14	19
28		67	90	98	M6x15	M8	36.5	23	7.6	14	22.5
32		71	90	98	M6x15	M8	38	24.5	7.6	15.5	24.5

	M_{n2}	M_{a2}	M_{p2}	n_{1N}	n_{1max}	ϕ_S	ϕ_R	C_t	R_{1max}	R_{2max}	A_{2max}	η	J_G [kgcm ²]			
													11 ... 12.7	14 ... 19	22 ; 24	28 ; 32
MPE 120 1_3	155	280	300	3000	4000	10'	5'	25	600	2000	2500	97	1.70	1.78	2.22	2.59
MPE 120 1_4	155	300	360	3000	4500	10'	5'	25	600	2000	2500	97	0.99	1.06	1.51	1.87
MPE 120 1_5	125	240	360	3000	4500	10'	5'	22	600	2000	2500	97	0.72	0.79	1.23	1.60
MPE 120 1_7	125	240	360	3500	4500	10'	5'	22	600	2000	2500	97	0.47	0.55	0.99	1.35
MPE 120 1_10	100	160	300	3500	5000	10'	5'	22	600	2000	2500	97	0.33	0.41	0.85	1.21
MPE 120 2_9	155	280	300	3000	4000	12'	7'	25	600	2000	2500	94	1.58	1.63	2.07	2.44
MPE 120 2_12	155	300	360	3000	4000	12'	7'	25	600	2000	2500	94	1.52	1.59	2.03	2.40
MPE 120 2_15	155	300	360	3000	4000	12'	7'	25	600	2000	2500	94	1.47	1.55	1.99	2.36
MPE 120 2_16	155	300	360	3000	4500	12'	7'	25	600	2000	2500	94	0.87	0.95	1.39	1.76
MPE 120 2_20	155	300	360	3000	4500	12'	7'	25	600	2000	2500	94	0.86	0.93	1.37	1.74
MPE 120 2_25	125	240	360	3000	4500	12'	7'	22	600	2000	2500	94	0.63	0.71	1.15	1.51
MPE 120 2_28	125	240	360	3500	5000	12'	7'	25	600	2000	2500	94	0.43	0.51	0.95	1.32
MPE 120 2_30	155	300	300	3500	5000	12'	7'	25	600	2000	2500	94	0.32	0.40	0.84	1.31
MPE 120 2_35	125	240	360	3500	5000	12'	7'	22	600	2000	2500	94	0.43	0.50	0.95	1.20
MPE 120 2_40	155	300	360	3500	5000	12'	7'	25	600	2000	2500	94	0.31	0.39	0.83	1.20
MPE 120 2_50	125	240	360	3500	5000	12'	7'	22	600	2000	2500	94	0.31	0.39	0.83	1.19
MPE 120 2_70	125	240	360	3500	5000	12'	7'	22	600	2000	2500	94	0.31	0.38	0.83	1.19
MPE 120 2_100	100	160	300	3500	5000	12'	7'	22	600	2000	2500	94	0.31	0.38	0.83	1.19

MPE



MPEK Series

The MPEK series offers medium levels of performance and position accuracy at a competitive value-price ratio. The output design in line with market standards ensures great compatibility for easy retrofits and a high level of freedom in projects development. Its right angle-design allows more compactness for space-saving layouts.

Main benefits

- Great price-performance ratio
- High compatibility for easy retrofits
- Suitable for a variety of applications thanks to great flexibility
- Compact design for space-saving layouts

Main features

- Nominal output torque (Nm)

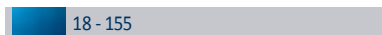

- Torsional backlash (arcmin)



- Torsional stiffness (Nm/arcmin)

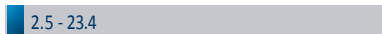

- Max tilting moment (Nm)

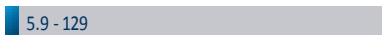

Protection class

- IP54

Frame sizes

- 060
- 080
- 120

Main options

- Input versions

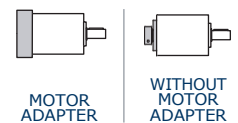

- Output shafts versions

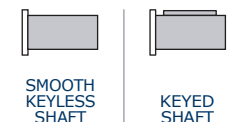

- Lubrication



13 FEATURES OF MPEK SERIES

The right-angle configuration of the MPEK Series is particularly suitable for compact, space-saving layouts. Its proportioned design allows quiet running and provides a long service life without maintenance requirements.

Motor mounting is an operation that can be easily conducted without the need of any particular tooling, other than that usually available in a normally equipped workshop.

- Available with either standard (STD) or reduced (LOW) backlash:
 2-stage units: standard $\phi_S \leq 12'$; reduced $\phi_R \leq 7'$
 3-stage units: standard $\phi_S \leq 14'$; reduced $\phi_R \leq 9'$
- Its degree of protection IP54 provides protection against dust and liquid splashes.
- Input section oil seals made from a Fluoroelastomer compound are supplied as standard*.
- Noise pressure level LP ≤ 70 dB(A). Conditions: distance 1 m; measured without load an input speed of $n_1 = 3000 \text{ min}^{-1}$; $i=10$.
- Units are factory packed with synthetic grease to NLGI consistency class 00, in the absence of contamination the lubricant requires no periodical changes.
- Ambient temperature min -20°C , max $+30^\circ\text{C}$. For temperature higher than 30°C please consider derating factor f_T .
- Housing temperature must not exceed $T_{\text{max}} = 90^\circ\text{C}$.

		Distribution of nominal torque M_{n2} [Nm]																	
	[i]	3	4	5	7	9	10	12	15	16	20	25	8	30	35	40	50	70	100
MPEK 060		29	30	25	25	29	18	29	29	30	30	30	30	29	30	30	30	30	18
MPEK 080		40	50	50	50	65	40	65	65	60	60	50	50	65	50	60	50	50	40
MPEK 120		80	105	130	125	155	100	155	155	155	155	125	125	155	125	155	125	125	100

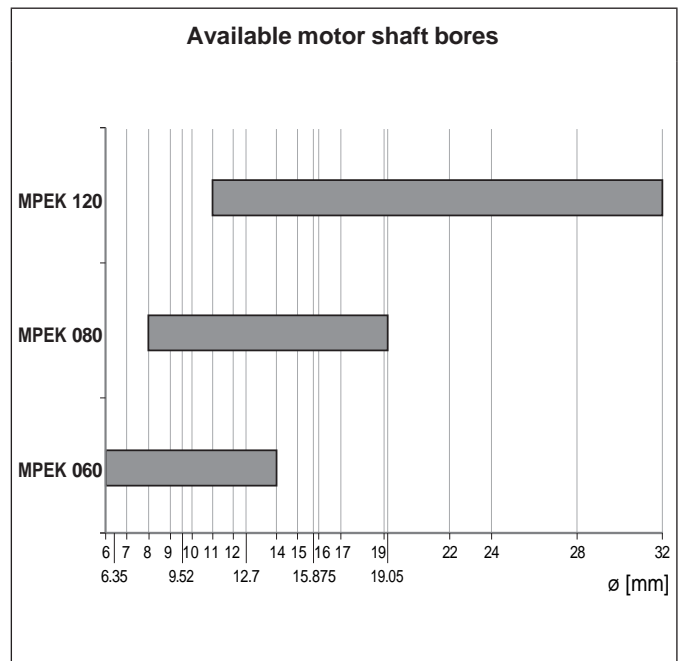
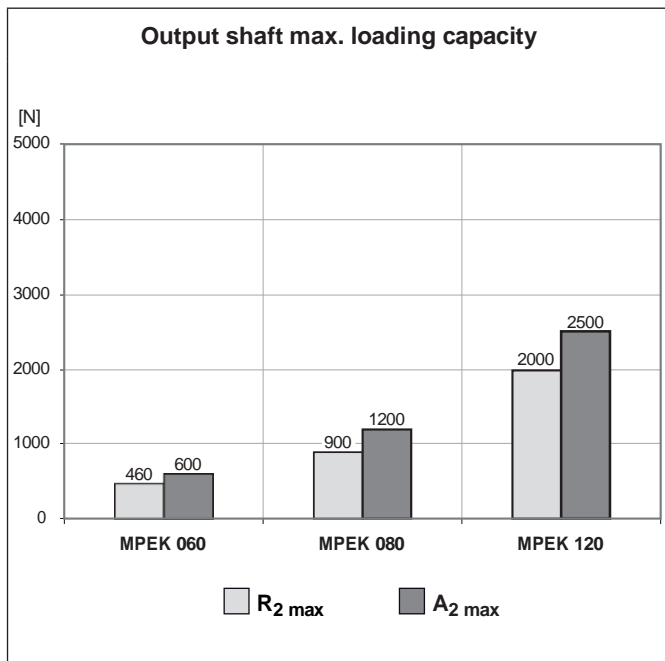

* not available for size 060

13.1 ORDERING CODE

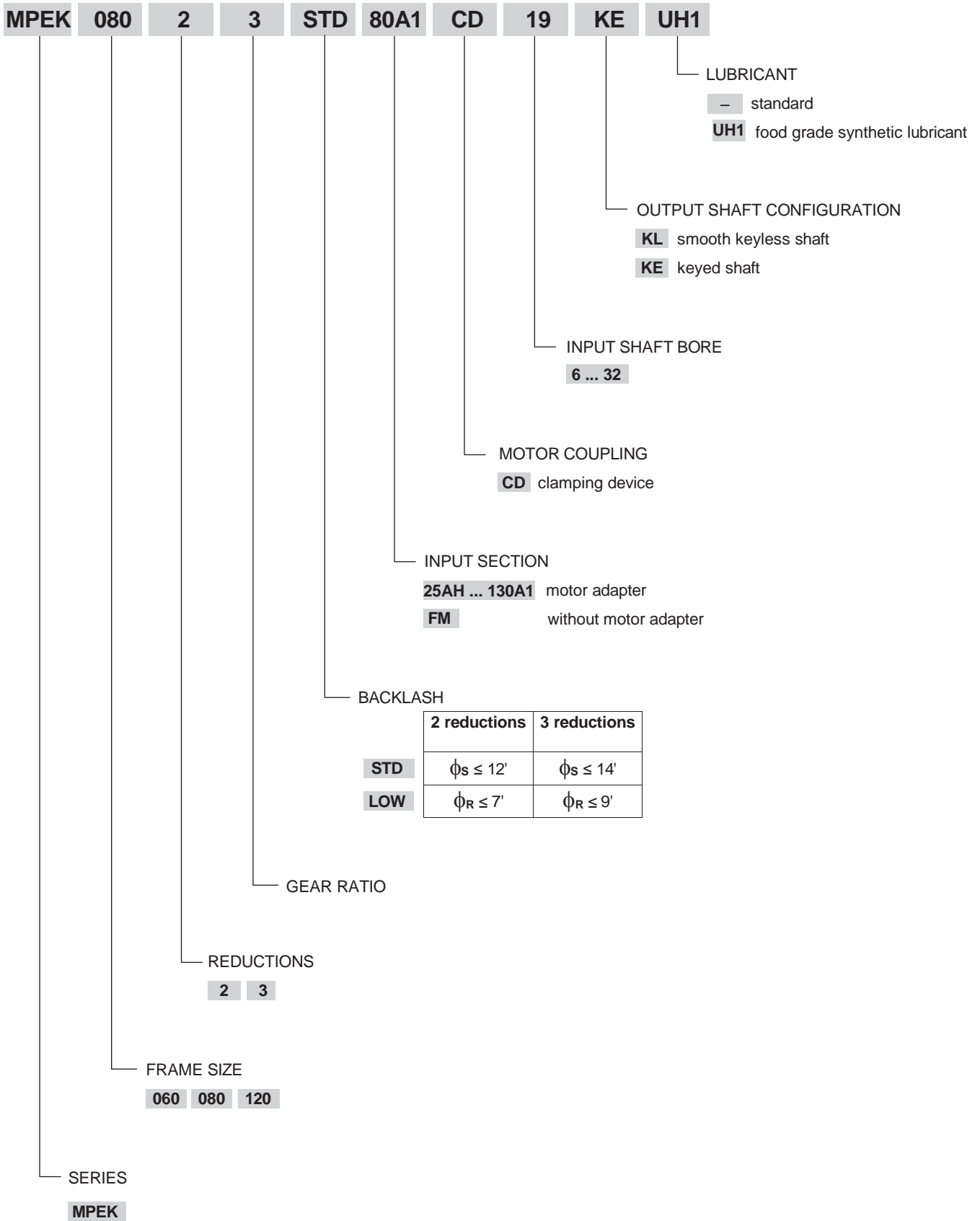

13.2 DIMENSIONS AND TECHNICAL SPECIFICATIONS

MPEK 060

25AH ... 80A

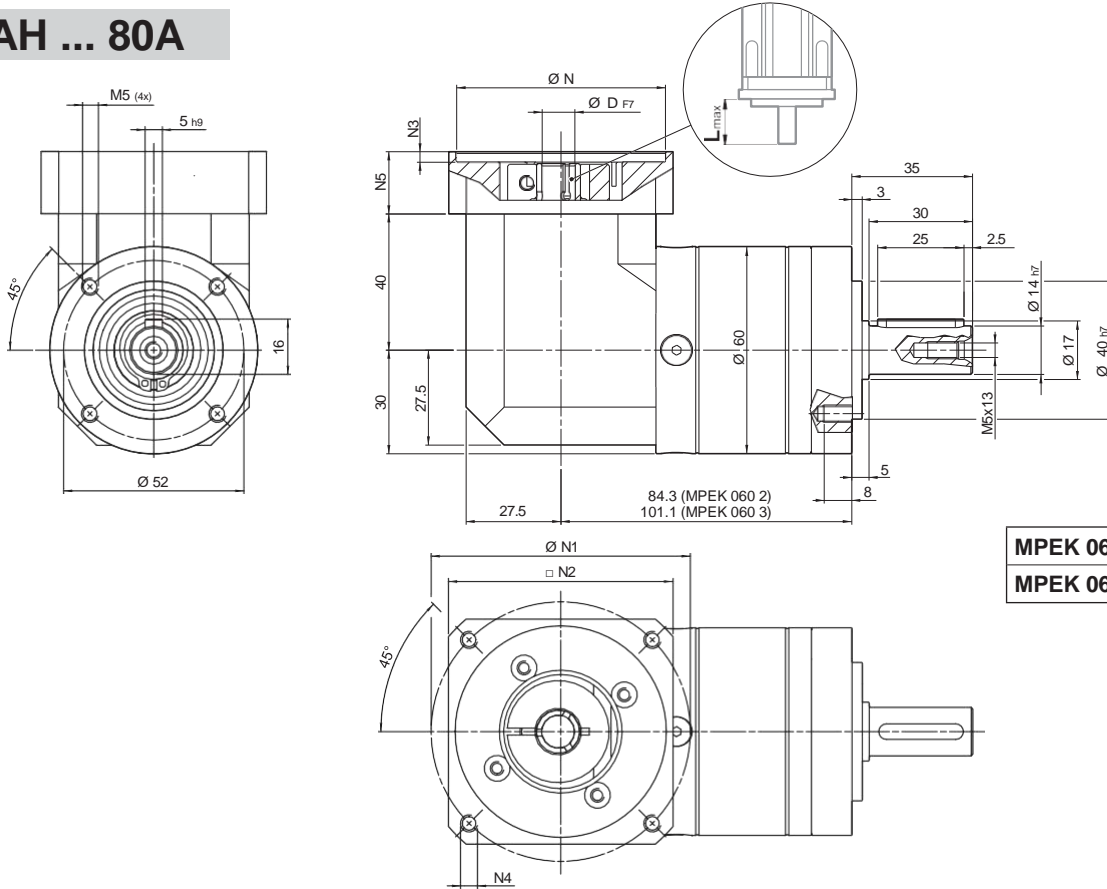

	Kg
MPEK 060 2	1.7
MPEK 060 3	2.2

											N	N1		N2	N3	N4	N5	L _{max}
	6	6.35	7	8	9	9.52	-	-	-	-		min	max					
25AH	6	6.35	7	8	9	9.52	-	-	-	-	25	39	56					
26AH	6	6.35	7	8	9	9.52	-	-	-	-	26	39	56					
28AH	6	6.35	7	8	9	9.52	-	-	-	-	28	39	56					
30AH	6	6.35	7	8	9	9.52	-	-	-	-	30	39	56					
32AH	6	6.35	7	8	9	9.52	-	-	-	-	32	39	56	65	3.5	4.5	25	25
34AH	6	6.35	7	8	9	9.52	-	-	-	-	34	40	56					
36AH	6	6.35	7	8	9	9.52	-	-	-	-	36	42	56					
39AH	6	6.35	7	8	9	9.52	-	-	-	-	39	45	56					
40AH	6	6.35	7	8	9	9.52	-	-	-	-	40	46	56					
38B	6	6.35	7	8	9	9.52	10	11	12	12.7	38.1	66.6	60	3	M4x10	18	25	
40B	6	6.35	7	8	9	9.52	10	11	12	12.7	40	63	60	3	M4x10	18	25	
50A	6	6.35	7	8	9	9.52	10	11	12	12.7	50	60	60	3	M4x10	18	25	
50B	6	6.35	7	8	9	9.52	10	11	12	12.7	50	65	60	3	M5x12	23	30	
50BH	6	6.35	7	8	9	9.52	10	11	12	12.7	50	65	65	3	5.5	25	32	
50C	6	6.35	7	8	9	9.52	10	11	12	12.7	50	70	60	3	M4x10	23	30	
55MH	6	6.35	7	8	9	9.52	10	11	12	12.7	55	80	65	2	5.5	16	23	
60A	6	6.35	7	8	9	9.52	10	11	12	12.7	60	75	65	3	M5x12	18	25	
60A1	6	6.35	7	8	9	9.52	10	11	12	12.7	60	75	65	3	M5x12	23	30	
60B	6	6.35	7	8	9	9.52	10	11	12	12.7	60	85	75	3	M5x12	23	30	
60C	6	6.35	7	8	9	9.52	10	11	12	12.7	60	90	75	3	M5x12	23	30	
70A	6	6.35	7	8	9	9.52	10	11	12	12.7	70	85	75	3	M6x15	23	30	
70B	6	6.35	7	8	9	9.52	10	11	12	12.7	70	90	75	3	M5x12	23	30	
73A	6	6.35	7	8	9	9.52	10	11	12	12.7	73	98.4	85	3	M5x12	25	32	
80A	6	6.35	7	8	9	9.52	10	11	12	12.7	80	100	85	3	M6x15	23	30	

MPEK

MPEK 060

FM

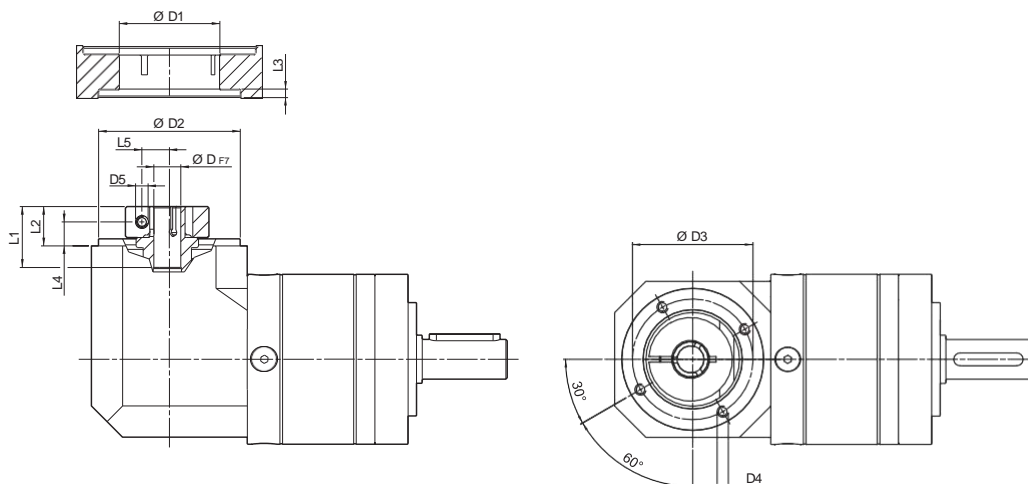

				D1	D2	D3	D4	D5	L1	L2	L3	L4	L5
6	6.35	7		32.5	50	42.5	M4x8	M4	21.7	13.2	3	8.2	8
8	9	9.52	10	32.5	50	42.5	M4x8	M4	21.7	13.2	3	8.2	9
11	12	12.7		35.5	50	42.5	M4x8	M4	22	13.5	3	8.5	11
14				35.5	50	42.5	M4x8	M4	25	17	3	10.2	11.5

	i	M _{n2}	M _{a2}	M _{p2}	n ₁	n _{1 max}	φ _S	φ _R	C _t	R _{1 max}	R _{2 max}	A _{2 max}	η	J _G [kgcm ²]	
		[Nm]	[Nm]	[Nm]	[rpm]	[rpm]	[arcmin]	[arcmin]	$\frac{Nm}{arcmin}$	[N]	[N]	[N]	%	6 ... 10	11 ... 14
MPEK 060 2_3		29	45	60	3300	4000	12'	7'	2.5	200	460	600	94	0.20	0.25
MPEK 060 2_4		30	45	70	3500	5000	12'	7'	2.5	200	460	600	94	0.20	0.22
MPEK 060 2_5		25	40	70	3500	5000	12'	7'	2.5	200	460	600	94	0.18	0.21
MPEK 060 2_7		25	40	70	4000	5000	12'	7'	2.5	200	460	600	94	0.18	0.20
MPEK 060 2_10		18	30	60	4000	6000	12'	7'	2.5	200	460	600	94	0.18	0.19
MPEK 060 3_9		29	55	60	3300	4000	14'	9'	2.5	200	460	600	91	0.21	0.22
MPEK 060 3_12		29	55	70	3300	4000	14'	9'	2.5	200	460	600	91	0.20	0.23
MPEK 060 3_15		29	55	70	3300	4000	14'	9'	2.5	200	460	600	91	0.20	0.22
MPEK 060 3_16		30	45	70	3500	5000	14'	9'	2.5	200	460	600	91	0.19	0.21
MPEK 060 3_20		30	45	70	3500	5000	14'	9'	2.5	200	460	600	91	0.18	0.20
MPEK 060 3_25		30	45	70	3500	5000	14'	9'	2.5	200	460	600	91	0.18	0.20
MPEK 060 3_28		30	45	70	4000	6000	14'	9'	2.5	200	460	600	91	0.18	0.20
MPEK 060 3_30		29	55	60	4000	6000	14'	9'	2.5	200	460	600	91	0.19	0.20
MPEK 060 3_35		30	45	70	4000	6000	14'	9'	2.5	200	460	600	91	0.19	0.20
MPEK 060 3_40		30	45	70	4000	6000	14'	9'	2.5	200	460	600	91	0.18	0.19
MPEK 060 3_50		30	45	70	4000	6000	14'	9'	2.5	200	460	600	91	0.18	0.19
MPEK 060 3_70		30	45	70	4000	6000	14'	9'	2.5	200	460	600	91	0.18	0.19
MPEK 060 3_100		18	30	60	4000	6000	14'	9'	2.5	200	460	600	91	0.18	0.19

MPEK

Please contact us for other motor adapters and input shaft bore.

MPEK 080

40B1 ... 110B1

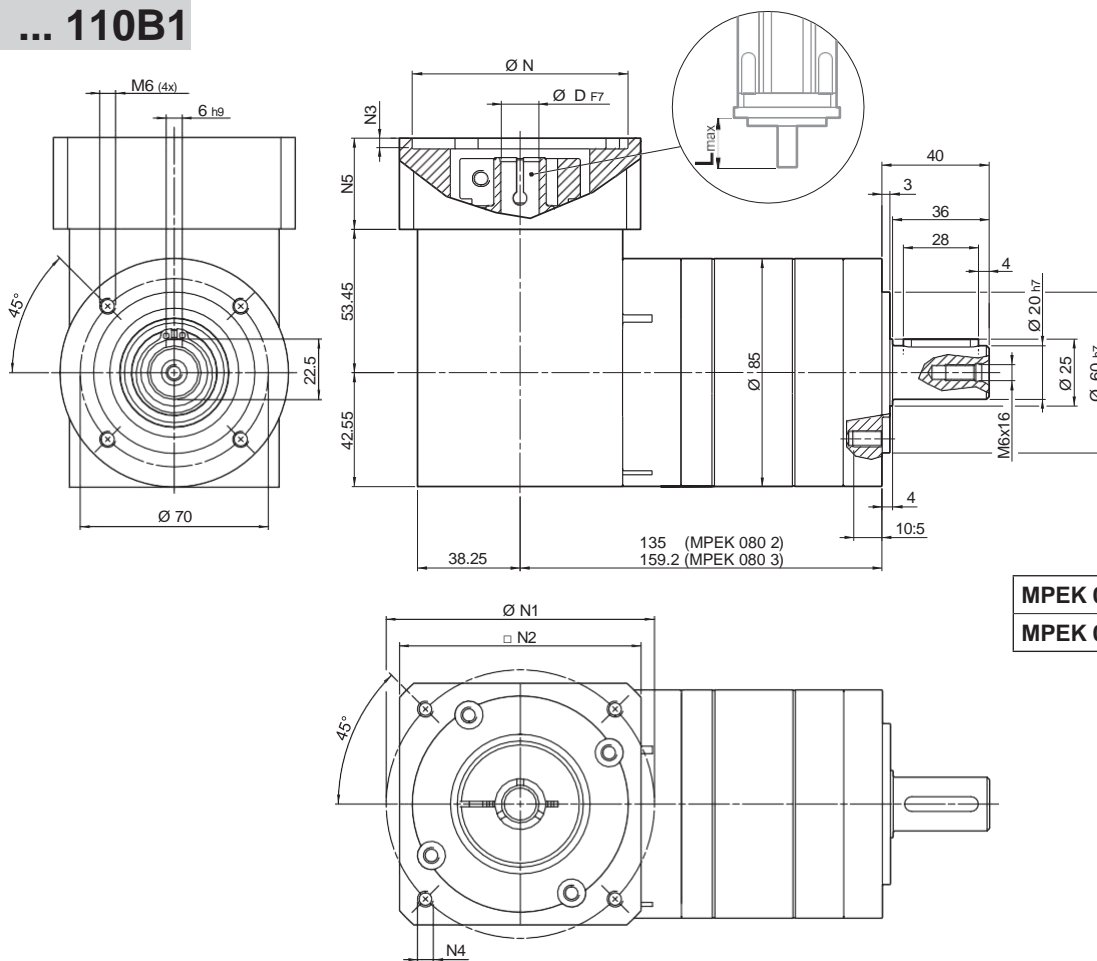

MPEK 080 2	4.7
MPEK 080 3	5.4

												N	N1	N2	N3	N4	N5	L _{max}	
40B1	8	9	9.52	11	12	12.7	14	-	-	-	-	40	63	80	4	M4x12	34	40	
45A	8	9	9.52	11	12	12.7	-	-	-	-	-	45	63	80	4	M4x12	34	40	
50B1	8	9	9.52	11	12	12.7	14	-	-	-	-	50	65	80	4	M5x16	34	40	
50BH1	8	9	9.52	11	12	12.7	14	-	-	-	-	50	65	80	4	5.5	34	40	
50C1	8	9	9.52	11	12	12.7	14	-	-	-	-	50	70	80	4	M4x10	34	40	
50D	8	9	9.52	11	12	12.7	14	-	-	-	-	50	95	80	4	M6x20	34	40	
55A	8	9	9.52	11	12	12.7	14	15.875	16	17	19	19.05	55.5	125.7	105	4	M6x20	34	40
60A2	8	9	9.52	11	12	12.7	14	-	-	-	-	60	75	80	4	M5x16	34	40	
60AH2	8	9	9.52	11	12	12.7	14	-	-	-	-	60	75	90	4	6.5	34	40	
60B1	8	9	9.52	11	12	12.7	14	15.875	16	-	-	60	85	80	4	M5x16	34	40	
60C1	8	9	9.52	11	12	12.7	14	15.875	16	-	-	60	90	80	4	M5x16	34	40	
70A1	8	9	9.52	11	12	12.7	14	15.875	16	17	19	19.05	70	85	80	4	M6x20	34	40
70AH1	8	9	9.52	11	12	12.7	14	15.875	16	17	19	19.05	70	85	90	4	6.5	34	40
70B1	8	9	9.52	11	12	12.7	14	15.875	16	17	19	19.05	70	90	80	4	M5x16	34	40
73A1	8	9	9.52	11	12	12.7	14	-	-	-	-	73	98.4	85	4	M5x16	34	40	
80A1	8	9	9.52	11	12	12.7	14	15.875	16	17	19	19.05	80	100	90	4	M6x16	34	40
95A	8	9	9.52	11	12	12.7	14	15.875	16	17	19	19.05	95	115	100	4	M8x20	34	40
95B	8	9	9.52	11	12	12.7	14	15.875	16	17	19	19.05	95	130	115	4	M8x20	34	40
110A	8	9	9.52	11	12	12.7	14	15.875	16	17	19	19.05	110	130	115	4	M8x20	34	40
110B	8	9	9.52	11	12	12.7	14	15.875	16	17	19	19.05	110	145	120	6.5	M8x20	44	50
110B1	8	9	9.52	11	12	12.7	14	15.875	16	17	19	19.05	110	145	120	6.5	M8x20	54	60

MPEK 080

FM

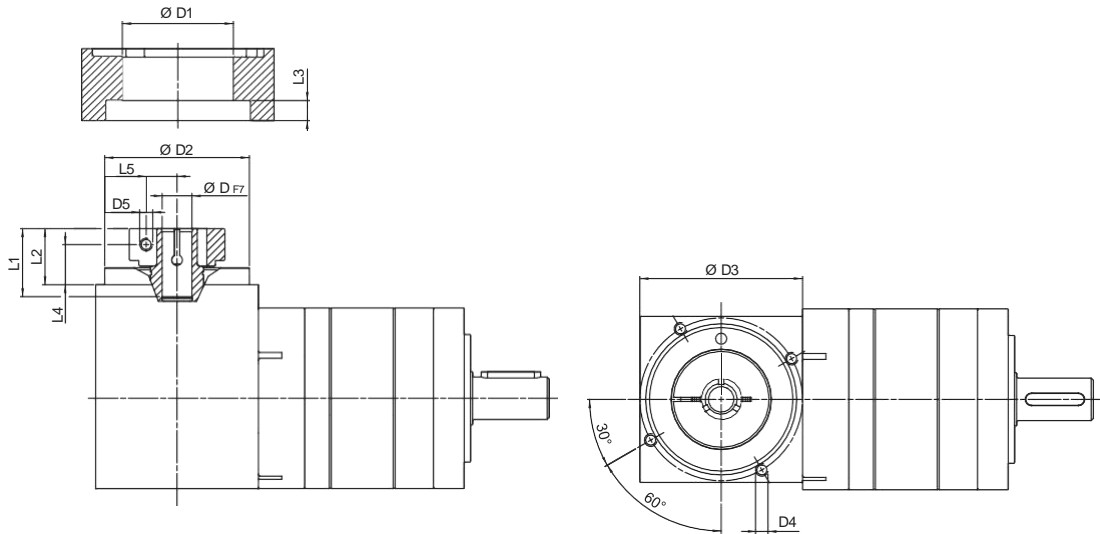

				D1	D2	D3	D4	D5	L1	L2	L3	L4	L5
8	9	9.52		38	68	76.5	M6x10	M6	34	26.8	9.5	18.8	10.5
11	12	12.7		43	68	76.5	M6x10	M6	34	26.8	9.5	18.8	12.5
14	15.875	16	17	48	68	76.5	M6x10	M6	34	26.8	9.5	18.8	14.5
19	19.05			51	68	76.5	M6x10	M6	34	26.8	9.5	18.8	16.5

	i	M _{n2}	M _{a2}	M _{p2}	n ₁	n _{1 max}	φ _S	φ _R	C _t	R _{1 max}	R _{2 max}	A _{2 max}	η	J _G [kgcm ²]	
		[Nm]	[Nm]	[Nm]	[rpm]	[rpm]	[arcmin]	[arcmin]	$\frac{Nm}{arcmin}$	[N]	[N]	[N]	%		8 ... 12.7
MPEK 080 2_3		40	60	150	2900	3500	12'	7'	11	400	900	1200	94	0.67	0.79
MPEK 080 2_4		50	80	160	3100	4500	12'	7'	11	400	900	1200	94	0.62	0.75
MPEK 080 2_5		50	80	160	3200	4500	12'	7'	8	400	900	1200	94	0.61	0.74
MPEK 080 2_7		50	80	160	4000	6000	12'	7'	8	400	900	1200	94	0.58	0.73
MPEK 080 2_10		40	70	150	4000	6000	12'	7'	8	400	900	1200	94	0.60	0.72
MPEK 080 3_9		65	120	150	2900	3500	14'	9'	11.5	400	900	1200	91	0.66	0.68
MPEK 080 3_12		65	120	160	3100	3500	14'	9'	11.5	400	900	1200	91	0.75	0.76
MPEK 080 3_15		65	120	160	3200	3500	14'	9'	11.5	400	900	1200	91	0.74	0.75
MPEK 080 3_16		60	110	160	3100	4500	14'	9'	11.5	400	900	1200	91	0.65	0.73
MPEK 080 3_20		60	110	160	3200	4500	14'	9'	11.5	400	900	1200	91	0.64	0.73
MPEK 080 3_25		50	100	160	3200	4500	14'	9'	8.5	400	900	1200	91	0.64	0.77
MPEK 080 3_28		50	100	160	4000	6000	14'	9'	8.5	400	900	1200	91	0.59	0.72
MPEK 080 3_30		65	120	150	4000	6000	14'	9'	11.5	400	900	1200	91	0.60	0.72
MPEK 080 3_35		50	100	160	4000	6000	14'	9'	8.5	400	900	1200	91	0.60	0.72
MPEK 080 3_40		60	110	160	4000	6000	14'	9'	11.5	400	900	1200	91	0.60	0.72
MPEK 080 3_50		50	100	160	4000	6000	14'	9'	8.5	400	900	1200	91	0.59	0.71
MPEK 080 3_70		50	100	160	4000	6000	14'	9'	8.5	400	900	1200	91	0.59	0.71
MPEK 080 3_100		40	70	150	4000	6000	14'	9'	8.5	400	900	1200	91	0.59	0.71

MPEK

Please contact us for other motor adapters and input shaft bore.

MPEK 120

50D ... 130A1

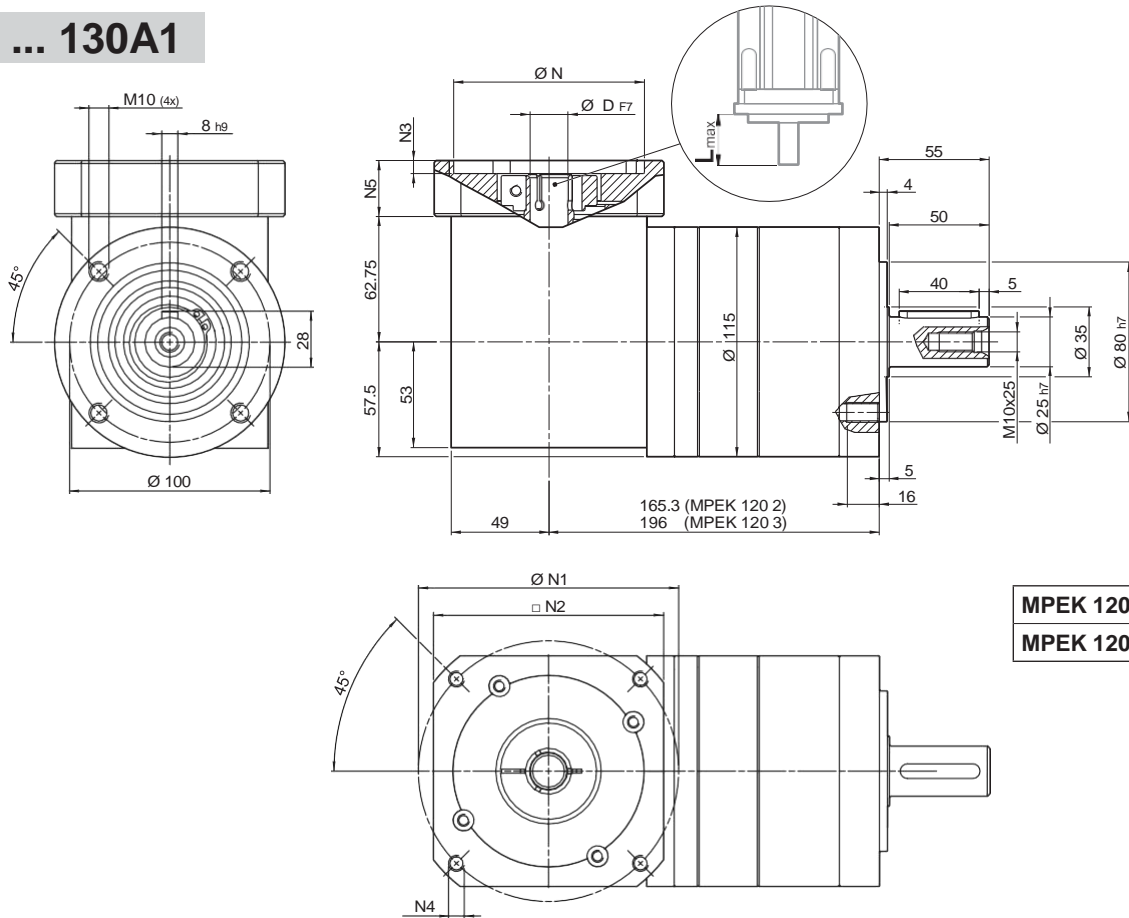

MPEK 120 2	7
MPEK 120 3	9.5

											N	N1	N2	N3	N4	N5	L _{max}	
50D	11	12	12.7	14	15	15.875	16	19	-	-	-	50	95	100	5	M6x14	28	40
55A	11	12	12.7	14	15	15.875	16	19	-	-	-	55	125.7	105	5	M6x16	28	40
60A2	11	12	12.7	14	15	15.875	16	19	-	-	-	60	75	100	6.5	M5x14	28	40
60AH2	11	12	12.7	14	15	15.875	16	19	-	-	-	60	75	100	4	6.5	33	40
60B1	11	12	12.7	14	15	15.875	16	19	-	-	-	60	85	100	6.5	M5x14	28	40
70A1	11	12	12.7	14	15	15.875	16	19	-	-	-	70	85	100	6.5	M6x14	28	40
70AH1	11	12	12.7	14	15	15.875	16	19	-	-	-	70	85	100	4	6.5	33	40
70B1	11	12	12.7	14	15	15.875	16	19	-	-	-	70	90	100	6.5	M5x12	28	40
80A1	11	12	12.7	14	15	15.875	16	19	-	-	-	80	100	100	6.5	M6x16	28	40
80AH1	11	12	12.7	14	15	15.875	16	19	-	-	-	80	100	100	4	6.5	33	40
95A	11	12	12.7	14	15	15.875	16	19	-	-	-	95	115	100	6.5	M8x18	28	40
95A1	11	12	12.7	14	15	15.875	16	19	22	24	-	95	115	100	6.5	M8x18	38	50
95B	11	12	12.7	14	15	15.875	16	19	-	-	-	95	130	115	6.5	M8x18	28	40
110A	11	12	12.7	14	15	15.875	16	19	-	-	-	110	130	115	6.5	M8x18	28	40
110A1	11	12	12.7	14	15	15.875	16	19	22	24	-	110	130	115	6.5	M8x20	38	50
110B	11	12	12.7	14	15	15.875	16	19	22	24	-	110	145	120	6.5	M8x20	38	50
110B1	11	12	12.7	14	15	15.875	16	19	22	24	28	110	145	120	6.5	M8x20	48	60
130A	11	12	12.7	14	15	15.875	16	19	22	24	-	130	165	140	6.5	M10x20	38	50
130A1	11	12	12.7	14	15	15.875	16	19	22	24	28	130	165	140	6.5	M10x25	48	60

MPEK

MPEK 120

FM

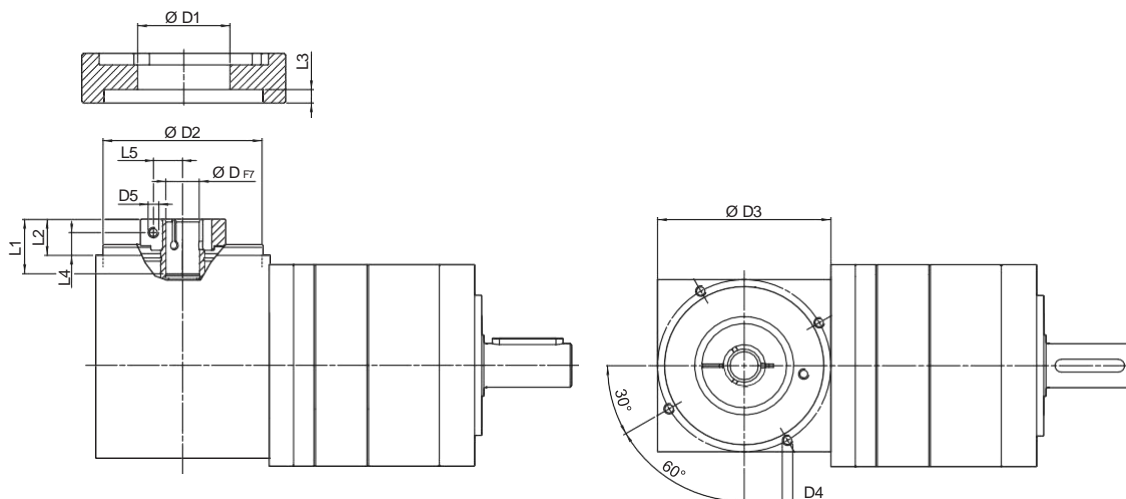

D				D1	D2	D3	D4	D5	L1	L2	L3	L4	L5
11	12	12.7		43	90	98	M6x15	M6	33.5	20	7.6	12	12.5
14	15	15.875	16	48	90	98	M6x15	M6	33.5	20	7.6	12.5	14.5
19				51	90	98	M6x15	M6	33.5	23	7.6	12.5	16.5
22	24			56.5	90	98	M6x15	M6	36.5	23	7.6	14	19
28				67	90	98	M6x15	M8	36.5	23	7.6	14	22.5
32				71	90	98	M6x15	M8	38	24.5	7.6	15.5	24.5

 i	M _{n2}	M _{a2}	M _{p2}	n _{1N}	n _{1 max}	φ _S	φ _R	C _t	R _{1 max}	R _{2 max}	A _{2 max}	η	J _G [kgcm ²]			
	[Nm]	[Nm]	[Nm]	[rpm]	[rpm]	[arcmin]	[arcmin]	$\frac{Nm}{1000}$	[N]	[N]	[N]	%	11 ... 12.7	14 ... 19	22 ; 24	28 ; 32
MPEK 090 2_3	80	120	300	3000	4000	12'	7'	23.4	600	2000	2500	94	1.85	1.92	2.33	3.07
MPEK 120 2_4	105	160	360	3000	4500	12'	7'	23.4	600	2000	2500	94	1.14	1.89	1.52	2.35
MPEK 120 2_5	130	195	360	3000	4500	12'	7'	20.4	600	2000	2500	94	1.07	1.21	1.34	2.08
MPEK 120 2_7	125	240	360	3500	4500	12'	7'	20.4	600	2000	2500	94	0.98	1.14	1.37	2.00
MPEK 120 2_10	100	160	300	3500	5000	12'	7'	20.4	600	2000	2500	94	0.94	1.09	1.23	1.95
MPEK 120 3_9	155	180	300	3000	4000	14'	9'	23.4	600	2000	2500	91	1.76	1.86	2.18	2.92
MPEK 120 3_12	155	300	360	3000	4000	14'	9'	23.4	600	2000	2500	91	1.60	1.75	2.14	2.84
MPEK 120 3_15	155	300	360	3000	4000	14'	9'	23.4	600	2000	2500	91	1.57	1.73	2.10	2.84
MPEK 120 3_16	155	300	360	3000	4500	14'	9'	23.4	600	2000	2500	91	1.02	1.18	1.40	2.24
MPEK 120 3_20	155	300	360	3000	4500	14'	9'	23.4	600	2000	2500	91	1.20	1.35	1.48	2.22
MPEK 120 3_25	125	240	360	3000	4500	14'	9'	20.4	600	2000	2500	91	1.13	1.29	1.42	2.15
MPEK 120 3_28	125	240	360	3500	5000	14'	9'	23.4	600	2000	2500	91	0.93	1.10	1.17	1.94
MPEK 120 3_30	155	300	300	3500	5000	14'	9'	23.4	600	2000	2500	91	0.93	1.08	1.22	2.05
MPEK 120 3_35	125	240	360	3500	5000	14'	9'	20.4	600	2000	2500	91	1.02	1.17	1.31	1.93
MPEK 120 3_40	155	300	360	3500	5000	14'	9'	23.4	600	2000	2500	91	0.96	1.11	1.25	1.98
MPEK 120 3_50	125	240	360	3500	5000	14'	9'	20.4	600	2000	2500	91	0.96	1.11	1.25	1.98
MPEK 120 3_70	125	240	360	3500	5000	14'	9'	20.4	600	2000	2500	91	0.92	1.06	1.21	1.93
MPEK 120 3_100	100	160	300	3500	5000	14'	9'	20.4	600	2000	2500	91	0.92	1.06	1.21	1.93

MPEK

Please contact us for other motor adapters and input shaft bore.



KR Series

The KR flexible series represents an alternative for applications that require space-saving and medium precision levels. It is available in multiple configurations such as solid/hollow shaft, single/double shaft extension, shrink disk version or flange option.

Main benefits

- Space saving solution
- Optimized backlash
- Wide variety of configurations
- Optional reinforced bearings

Main features

- Nominal output torque (Nm)



- Torsional backlash (arcmin)



- Torsional stiffness (Nm/arcmin)



Protection class

- IP65

Frame sizes

- 010
- 020
- 030
- 040

Main options

- Input versions

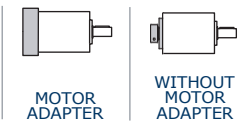

- Output shafts versions

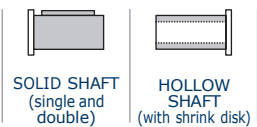

- Service type



- Bearings versions



14 FEATURES OF KR SERIES

Bevel helical units type KR, manufactured under the most stringent quality specifications, are designed for dynamic and accurate applications where light weight and space effectiveness are a factor.

Many options can be selected from the catalogue as far as motor adapters and output shaft configurations that facilitate the installation on the driven equipment.

- Available in one only backlash option ($\phi_s \leq 8'$)
- Single reduction: ratios $i = 1, 2, 5$
- Radial ball bearings (SB) are of standard supply, while taper roller bearings (HB) can be optionally specified for particularly demanding loading conditions
- Degree of protection IP65
- Oil seals from fluoroelastomer compound as standard
- Noise pressure level $L_p \leq 70$ dB(A). Conditions: distance 1 m; measured without load an input speed of $n_1 = 3000 \text{ min}^{-1}$
- Lubrication optimized for the type of duty specified when ordering, in the absence of contamination the lubricant requires no periodical changes.

duty	KR 010 ... KR 040
S1 (continuous)	Synthetic oil viscosity ISO VG 220
S5 (intermittent)	NLGI grease consistency 00



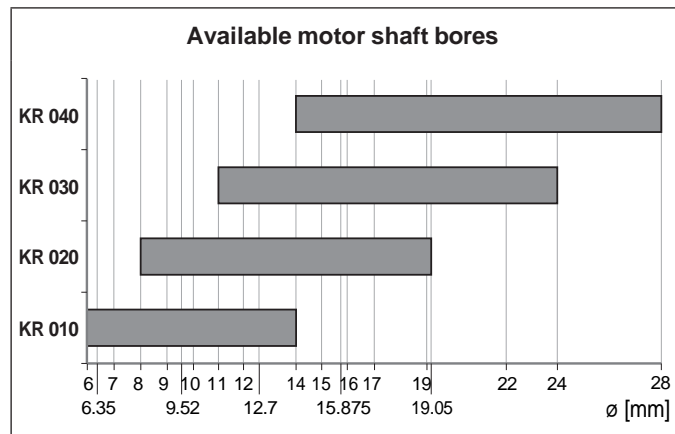

- Ambient temperature min -20°C , max $+30^\circ\text{C}$. For temperature higher than 30°C please consider derating factor f_r .
- Housing temperature must not exceed $T_{\text{max}} = 90^\circ\text{C}$.

Distribution of nominal torque		M_{n2} [Nm]		
[i]	1	2	5	
KR 010	10	7	3	
KR 020	24	15	10	
KR 030	55	37	22	
KR 040	120	85	45	







14.1 VERSIONS

Solid shaft

LP	LPF	LD	LDF
			
single extension	single extension + flange	double extension	double extension + flange

Hollow shaft

H	HF	S	SF
			
keyed (KR 030...KR 040)	keyed shaft + flange (KR 030...KR 040)	with shrink disc	with shrink disc + flange

14.2 MOUNTING POSITIONS

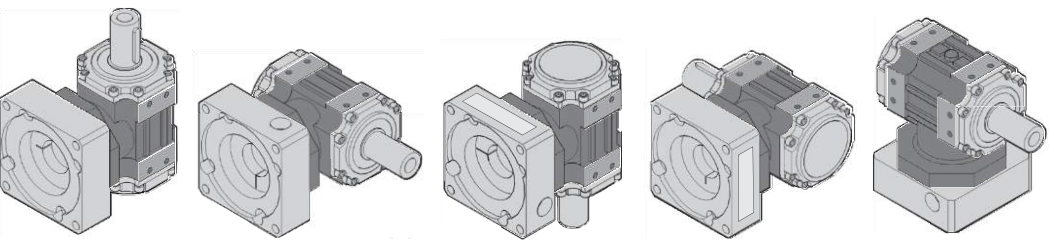
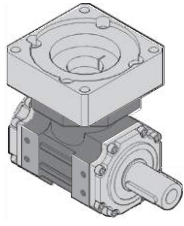
U	VA
	

14.3 COORDINATED SHAFT ROTATION

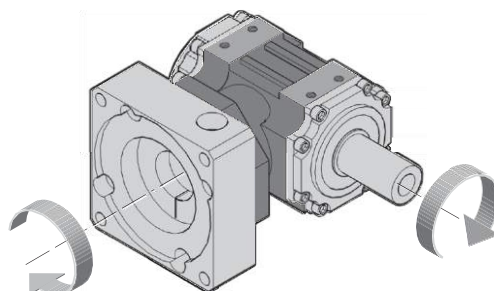

14.4 ORDERING CODE

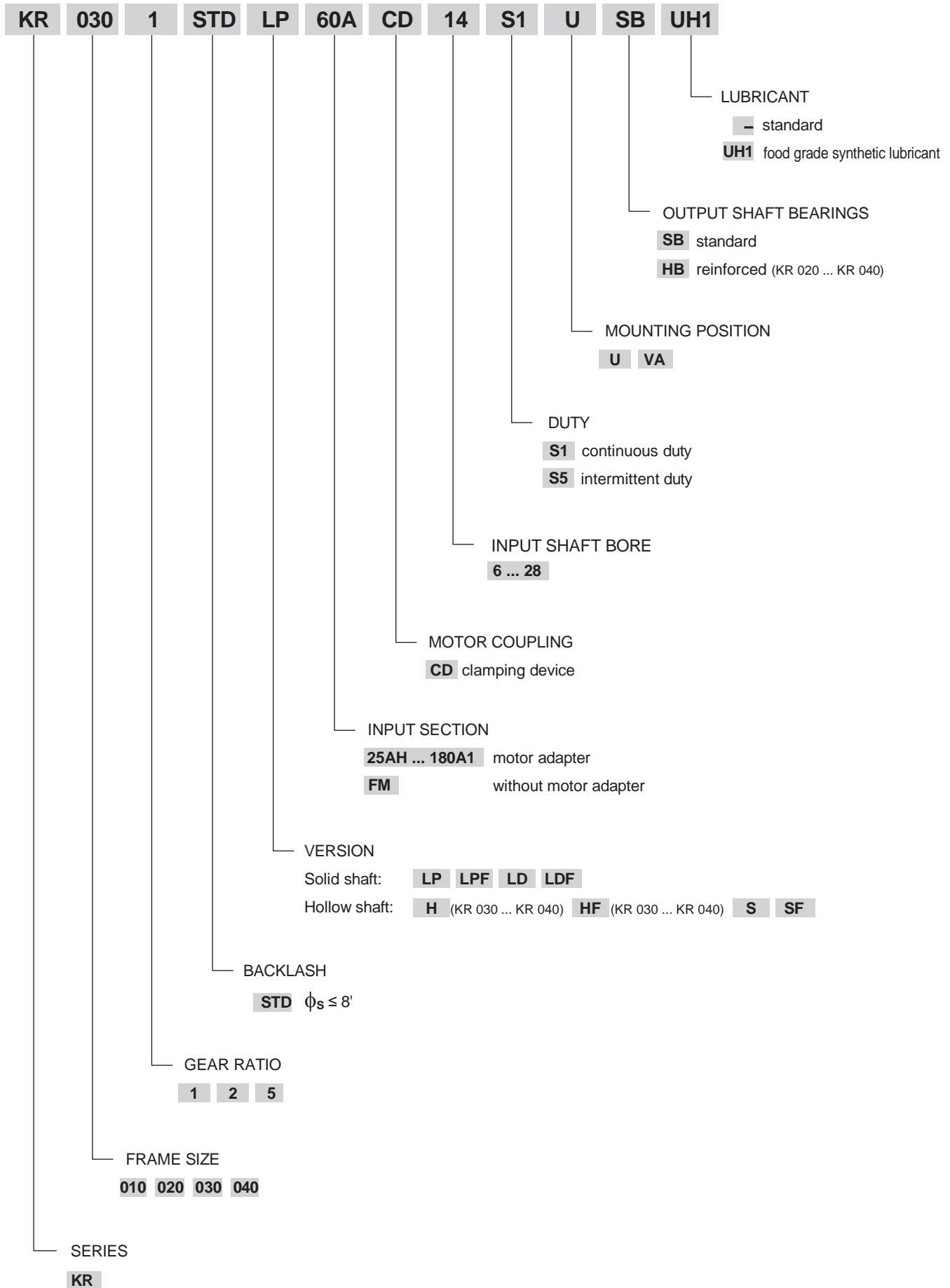

14.5 TECHNICAL SPECIFICATIONS

KR 010								
	M_{n2}	M_{a2}	M_{p2}	C_t	n_1	$n_{1\ max}$	ϕ_s	η
	[Nm]	[Nm]	[Nm]	$\frac{Nm}{arcmin}$	[min ⁻¹]	[min ⁻¹]	[arcmin]	%
i = 1	10	14	20	0.5	2000	4000		
i = 2	7	10	15	0.4	2500	5000	8'	97
i = 5	3	4	6	0.2	3000	5000		

KR 020								
	M_{n2}	M_{a2}	M_{p2}	C_t	n_1	$n_{1\ max}$	ϕ_s	η
	[Nm]	[Nm]	[Nm]	$\frac{Nm}{arcmin}$	[min ⁻¹]	[min ⁻¹]	[arcmin]	%
i = 1	24	35	50	1.4	2000	4000		
i = 2	15	21	30	1.1	2500	5000	8'	97
i = 5	10	13	20	0.7	3000	5000		

KR 030								
	M_{n2}	M_{a2}	M_{p2}	C_t	n_1	$n_{1\ max}$	ϕ_s	η
	[Nm]	[Nm]	[Nm]	$\frac{Nm}{arcmin}$	[min ⁻¹]	[min ⁻¹]	[arcmin]	%
i = 1	55	75	110	4	1500	3500		
i = 2	37	52	75	3	2000	4500	8'	97
i = 5	22	29	45	2	2800	4500		

KR 040								
	M_{n2}	M_{a2}	M_{p2}	C_t	n_1	$n_{1\ max}$	ϕ_s	η
	[Nm]	[Nm]	[Nm]	$\frac{Nm}{arcmin}$	[min ⁻¹]	[min ⁻¹]	[arcmin]	%
i = 1	120	170	240	11	1500	3500		
i = 2	85	120	170	9	2000	4500	8'	97
i = 5	45	60	90	5	2500	4500		

Stiffness value is referred to LP version

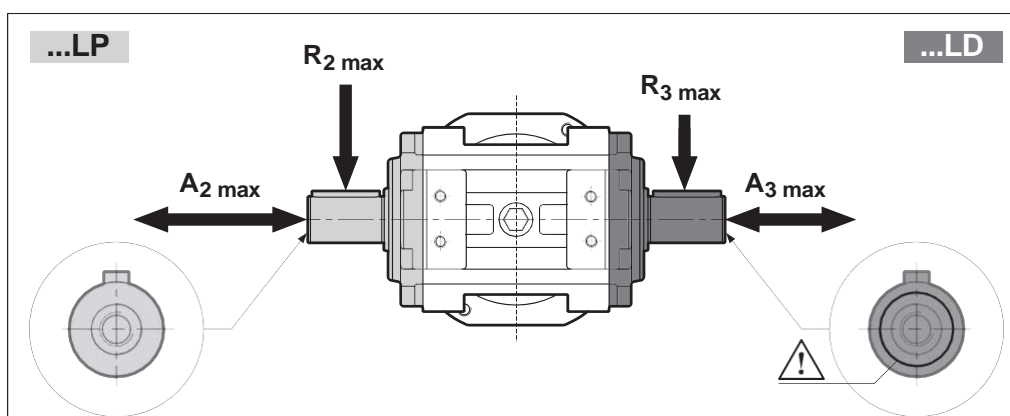

	...LP			...LD		
	$R_{2\ max}$	$A_{2\ max}$	$A_{2'\ max}$	$R_{3\ max}$	$A_{3\ max}$	$A_{3'\ max}$
	[N]	[N]	[N]	[N]	[N]	[N]
KR 010 SB	1000	—	200	500	—	100
KR 020 SB	1500	—	300	750	—	150
KR 020 HB	3000	1500	600	3000	1500	600
KR 030 SB	2000	—	400	1000	—	200
KR 030 HB	4000	2000	800	4000	2000	800
KR 040 SB	3000	—	600	1500	—	300
KR 040 HB	5500	2750	1100	5500	2750	1100

KR

14.6 MASS MOMENT OF INERTIA

14.6.1 KR 010...KR 040 with standard ball bearings - SB





KR 010			
		J_G [kgcm ²]	
		$6 \leq D \leq 9.52$	$10 \leq D \leq 14$
i = 1	S, SF	0.52	0.52
	LP, LPF	0.38	0.38
	LD, LDF	0.39	0.39
i = 2	S, SF	0.27	0.29
	LP, LPF	0.24	0.25
	LD, LDF	0.24	0.25
i = 5	S, SF	0.20	0.21
	LP, LPF	0.19	0.21
	LD, LDF	0.19	0.21



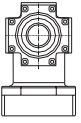

KR 020			
		J_G [kgcm ²]	
		$8 \leq D \leq 12.7$	$14 \leq D \leq 19.05$
i = 1	S, SF	1.61	1.80
	LP, LPF	1.34	1.52
	LD, LDF	1.37	1.55
i = 2	S, SF	0.86	1.05
	LP, LPF	0.80	0.98
	LD, LDF	0.80	0.99
i = 5	S, SF	0.66	0.84
	LP, LPF	0.64	0.83
	LD, LDF	0.65	0.83



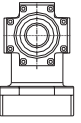

KR 030				
		J_G [kgcm ²]		
		$11 \leq D \leq 12.7$	$14 \leq D \leq 19$	$22 \leq D \leq 24$
i = 1	H, HF	4.37	4.45	4.64
	S, SF	5.00	5.08	5.27
	LP, LPF	4.70	4.78	4.97
	LD, LDF	4.63	4.71	4.90
i = 2	H, HF	2.04	2.12	2.31
	S, SF	2.20	2.28	2.47
	LP, LPF	2.12	2.20	2.39
	LD, LDF	2.11	2.19	2.37
i = 5	H, HF	1.47	1.55	1.74
	S, SF	1.50	1.57	1.76
	LP, LPF	1.48	1.56	1.75
	LD, LDF	1.48	1.56	1.75

KR 040				
		J_G [kgcm ²]		
		$14 \leq D \leq 19$	$22 \leq D \leq 24$	$D = 28$
i = 1	H, HF	17.19	17.37	17.77
	S, SF	20.46	20.65	21.05
	LP, LPF	18.21	18.40	18.80
	LD, LDF	18.90	19.08	19.48
i = 2	H, HF	4.47	4.65	5.06
	S, SF	5.29	5.47	5.87
	LP, LPF	4.73	4.91	5.31
	LD, LDF	4.90	5.08	5.48
i = 5	H, HF	5.23	5.42	5.82
	S, SF	5.36	5.55	5.95
	LP, LPF	5.27	5.46	5.86
	LD, LDF	5.30	5.49	5.89

14.6.2 KR 020...KR 040 with taper roller bearings - HB

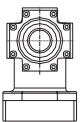
KR 020			
 		J_G [kgcm ²]	
			
HB 		$8 \leq D \leq 12.7$	$14 \leq D \leq 19.05$
i = 1	S, SF	1.87	2.06
	LP, LPF	1.60	1.78
	LD, LDF	1.62	1.81
i = 2	S, SF	0.93	1.12
	LP, LPF	0.86	1.05
	LD, LDF	0.87	1.05
i = 5	S, SF	0.67	0.85
	LP, LPF	0.66	0.84
	LD, LDF	0.66	0.84

KR 030				
 		J_G [kgcm ²]		
				
HB 		$11 \leq D \leq 12.7$	$14 \leq D \leq 19$	$22 \leq D \leq 24$
i = 1	H, HF	5.48	5.56	5.75
	S, SF	6.11	6.19	6.38
	LP, LPF	5.81	5.89	6.08
	LD, LDF	5.74	5.82	6.01
i = 2	H, HF	2.92	3.00	3.19
	S, SF	3.08	3.16	3.35
	LP, LPF	3.01	3.09	3.27
	LD, LDF	2.99	3.07	3.26
i = 5	H, HF	1.51	1.59	1.78
	S, SF	1.54	1.62	1.81
	LP, LPF	1.53	1.61	1.80
	LD, LDF	1.53	1.60	1.79

KR 040				
 		J_G [kgcm ²]		
				
HB 		$14 \leq D \leq 19$	$22 \leq D \leq 24$	$D = 28$
i = 1	H, HF	18.82	19.01	19.41
	S, SF	22.10	22.28	22.69
	LP, LPF	19.85	20.04	20.44
	LD, LDF	20.53	20.72	21.12
i = 2	H, HF	4.88	5.06	5.47
	S, SF	5.70	6.28	6.28
	LP, LPF	5.13	5.72	5.72
	LD, LDF	5.31	5.89	5.89
i = 5	H, HF	5.30	5.48	5.89
	S, SF	5.43	6.02	6.02
	LP, LPF	5.34	5.93	5.93
	LD, LDF	5.37	5.95	5.95

14.7 DIMENSIONS

KR 010

25AH ... 80A

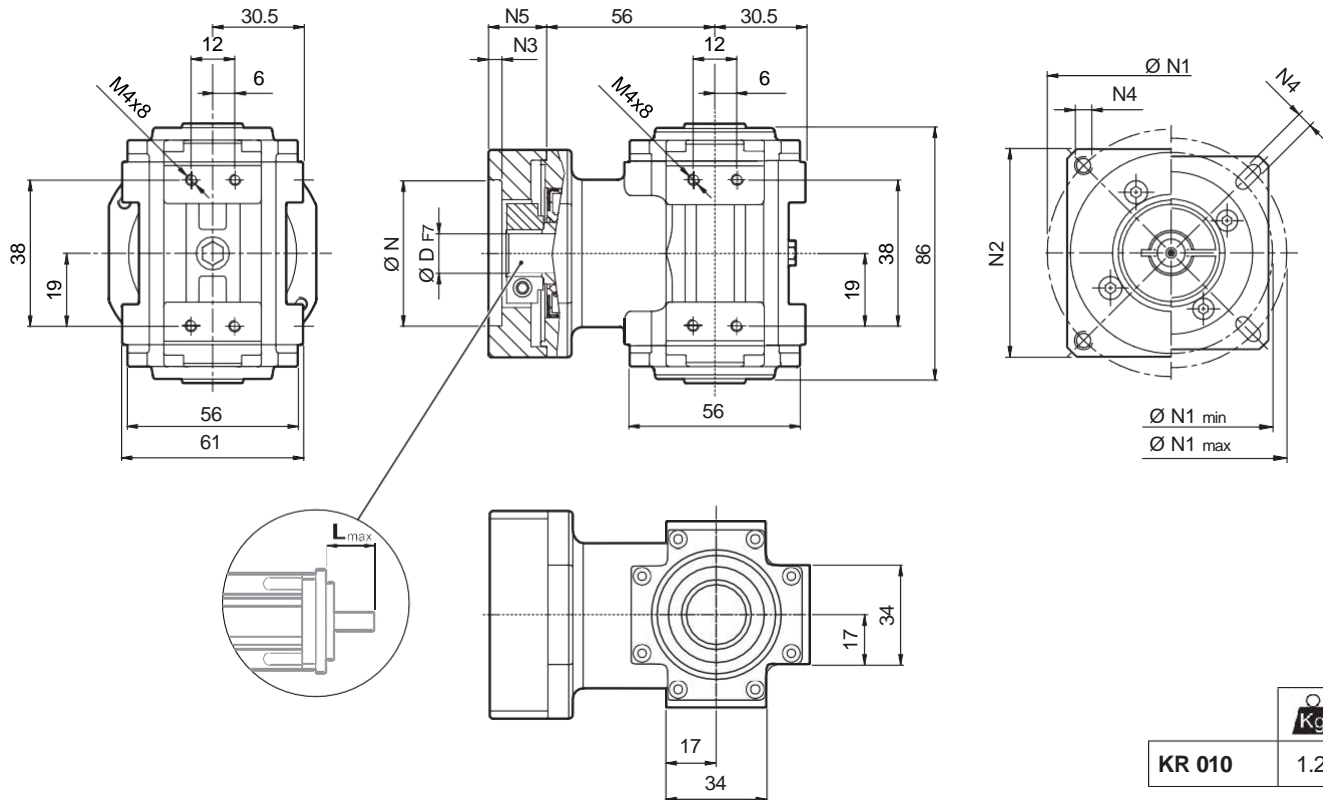

	D	N	N1		N2	N3	N4	N5	L _{max}
			min	max					
25AH	6 6.35 7 8 9 9.52 - - - - -	25	39	56					
26AH	6 6.35 7 8 9 9.52 - - - - -	26	39	56					
28AH	6 6.35 7 8 9 9.52 - - - - -	28	39	56					
30AH	6 6.35 7 8 9 9.52 - - - - -	30	39	56					
32AH	6 6.35 7 8 9 9.52 - - - - -	32	39	56	65	3.5	4.5	25	25
34AH	6 6.35 7 8 9 9.52 - - - - -	34	40	56					
36AH	6 6.35 7 8 9 9.52 - - - - -	36	42	56					
39AH	6 6.35 7 8 9 9.52 - - - - -	39	45	56					
40AH	6 6.35 7 8 9 9.52 - - - - -	40	46	56					
38B	6 6.35 7 8 9 9.52 10 11 12 12.7 -	38.1	66.6		60	3	M4x10	18	25
40B	6 6.35 7 8 9 9.52 10 11 12 12.7 -	40	63		60	3	M4x10	18	25
50A	6 6.35 7 8 9 9.52 10 11 12 12.7 -	50	60		60	3	M4x10	18	25
50B	6 6.35 7 8 9 9.52 10 11 12 12.7 14	50	65		60	3	M5x12	23	30
50BH	6 6.35 7 8 9 9.52 10 11 12 12.7 14	50	65		65	3	5.5	25	32
50C	6 6.35 7 8 9 9.52 10 11 12 12.7 14	50	70		60	3	M4x10	23	30
55MH	6 6.35 7 8 9 9.52 10 11 12 12.7 -	55	80		65	2	5.5	16	23
60A	6 6.35 7 8 9 9.52 10 11 12 12.7 -	60	75		65	3	M5x12	18	25
60A1	6 6.35 7 8 9 9.52 10 11 12 12.7 14	60	75		65	3	M5x12	23	30
60B	6 6.35 7 8 9 9.52 10 11 12 12.7 14	60	85		75	3	M5x12	23	30
60C	6 6.35 7 8 9 9.52 10 11 12 12.7 14	60	90		75	3	M5x12	23	30
70A	6 6.35 7 8 9 9.52 10 11 12 12.7 14	70	85		75	3	M6x15	23	30
70B	6 6.35 7 8 9 9.52 10 11 12 12.7 14	70	90		75	5	M5x12	23	30
73A	6 6.35 7 8 9 9.52 10 11 12 12.7 14	73	98.4		85	3	M5x12	25	32
80A	6 6.35 7 8 9 9.52 10 11 12 12.7 14	80	100		85	3	M6x15	23	30

Please contact us for different motor adapters and input shaft bore.

KR 010

KR 010... S

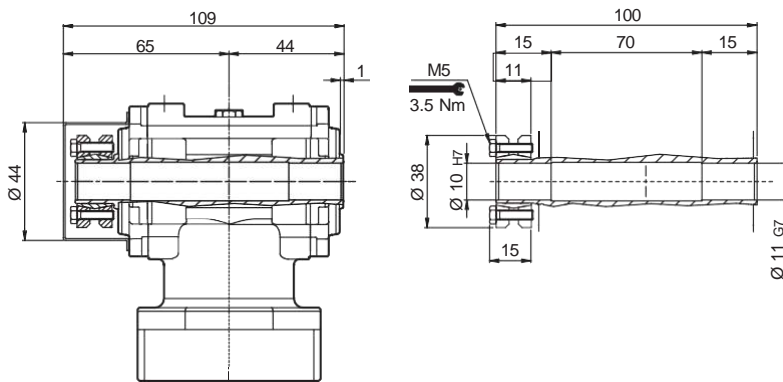

KR 010... SF

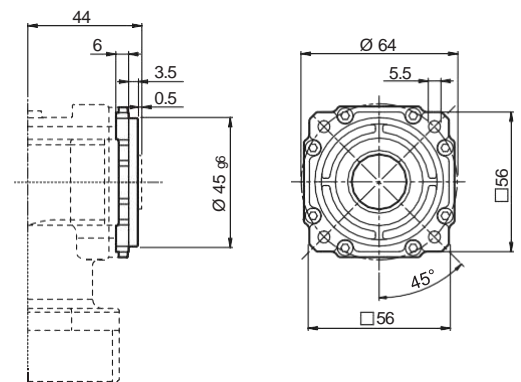

KR 010... LP

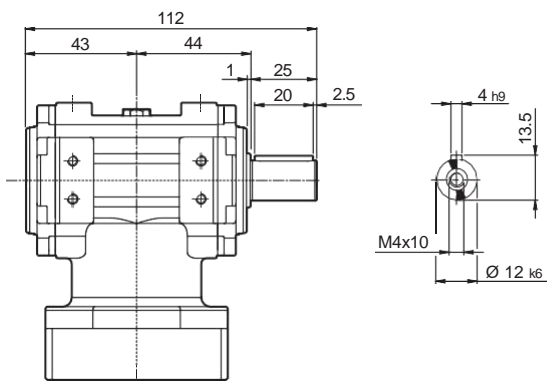

KR 010... LPF

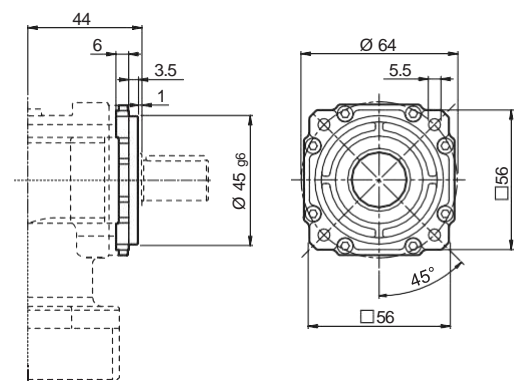

KR 010... LD

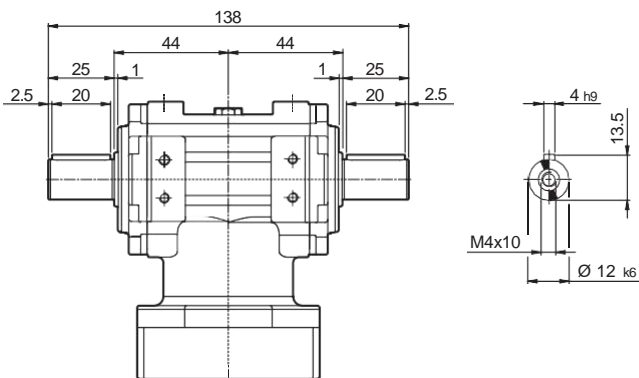

KR 010... LDF

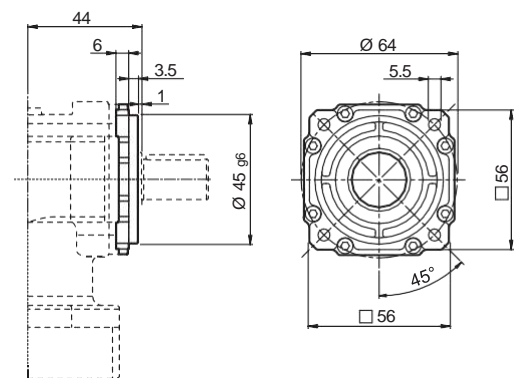

KR 020

40B1 ... 110B1

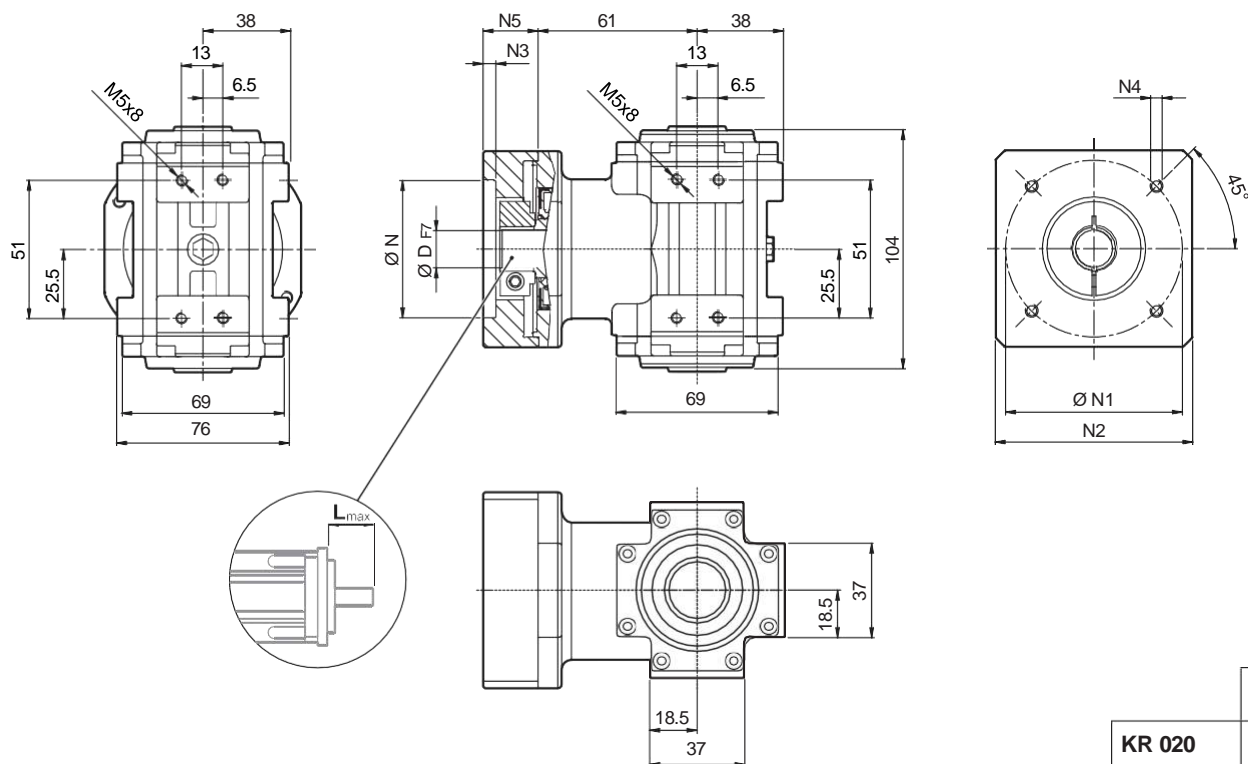
KR 020

2.6

												N	N1	N2	N3	N4	N5	L _{max}	
	8	9	9.52	11	12	12.7	14	-	-	-	-								
40B1	8	9	9.52	11	12	12.7	14	-	-	-	-	40	63	80	4	M4x10	34	40	
45A	8	9	9.52	11	12	12.7	-	-	-	-	-	45	63	80	4	M4x10	34	40	
50B1	8	9	9.52	11	12	12.7	14	-	-	-	-	50	65	80	4	M5x16	34	40	
50BH1	8	9	9.52	11	12	12.7	14	-	-	-	-	50	65	80	4	5.5	34	40	
50C1	8	9	9.52	11	12	12.7	14	-	-	-	-	50	70	80	4	M4x10	34	40	
50D	8	9	9.52	11	12	12.7	14	-	-	-	-	50	95	80	4	M6x10	34	40	
55A	8	9	9.52	11	12	12.7	14	15.875	16	17	19	19.05	55.5	125.7	105	4	M6x16	34	40
60A2	8	9	9.52	11	12	12.7	14	-	-	-	-	60	75	80	4	M5x16	34	40	
60AH2	8	9	9.52	11	12	12.7	14	-	-	-	-	60	75	90	4	5.5	34	40	
60B1	8	9	9.52	11	12	12.7	14	15.875	16	-	-	60	85	80	4	M5x16	34	40	
60C1	8	9	9.52	11	12	12.7	14	15.875	16	-	-	60	90	80	4	M5x16	34	40	
70A1	8	9	9.52	11	12	12.7	14	15.875	16	17	19	19.05	70	85	80	4	M6x20	34	40
70AH1	8	9	9.52	11	12	12.7	14	15.875	16	17	19	19.05	70	85	90	4	6.5	34	40
70B1	8	9	9.52	11	12	12.7	14	15.875	16	17	19	19.05	70	90	80	4	M5x16	34	40
73A1	8	9	9.52	11	12	12.7	14	-	-	-	-	73	98.4	85	4	M5x16	34	40	
80A1	8	9	9.52	11	12	12.7	14	15.875	16	17	19	19.05	80	100	90	4	M6x16	34	40
95A	8	9	9.52	11	12	12.7	14	15.875	16	17	19	19.05	95	115	100	4	M8x20	34	40
95B	8	9	9.52	11	12	12.7	14	15.875	16	17	19	19.05	95	130	115	4	M8x20	34	40
110A	8	9	9.52	11	12	12.7	14	15.875	16	17	19	19.05	110	130	115	4	M8x20	34	40
110B	8	9	9.52	11	12	12.7	14	15.875	16	17	19	19.05	110	145	120	6.5	M8x20	44	50
110B1	8	9	9.52	11	12	12.7	14	15.875	16	17	19	19.05	110	145	120	6.5	M8x20	54	60

Please contact us for different motor adapters and input shaft bore.

KR 020

KR 020... S

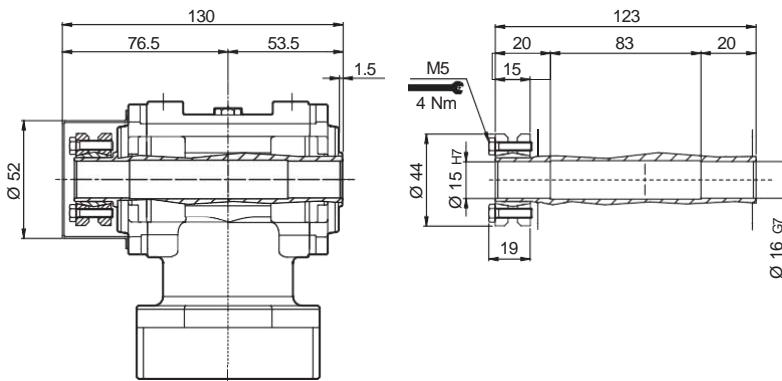

KR 020... SF

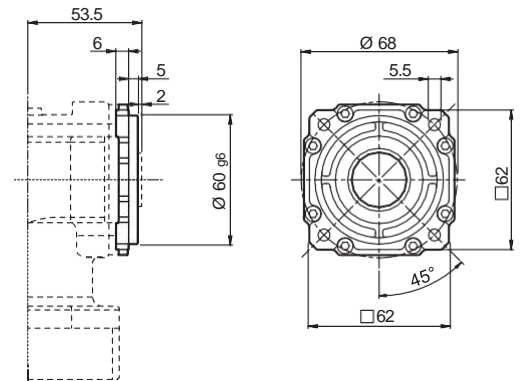

KR 020... LP

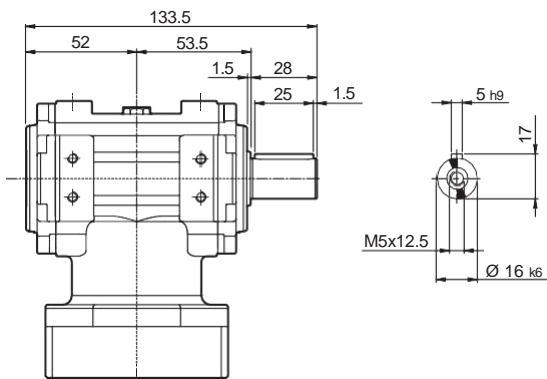

KR 020... LPF

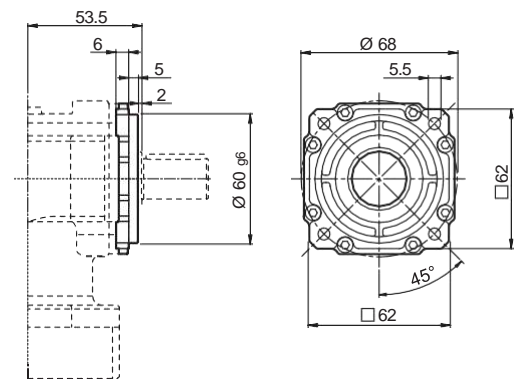

KR 020... LD

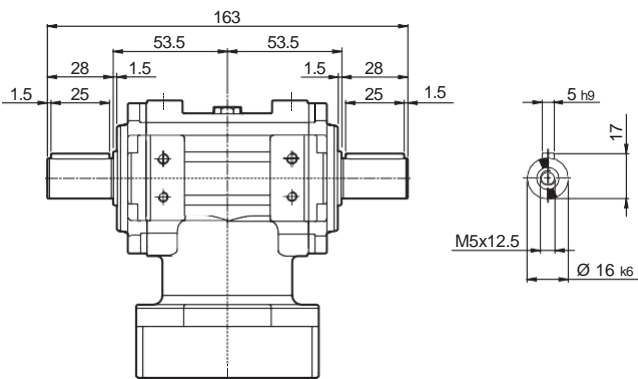

KR 020... LDF

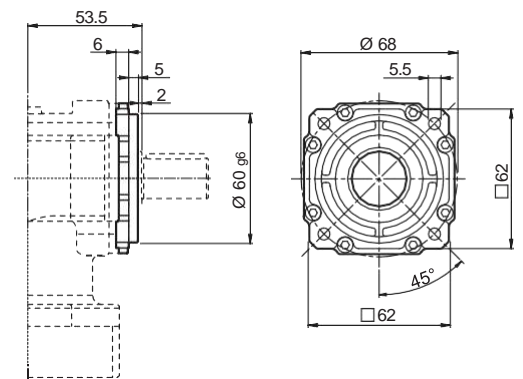

50D ... 130A1

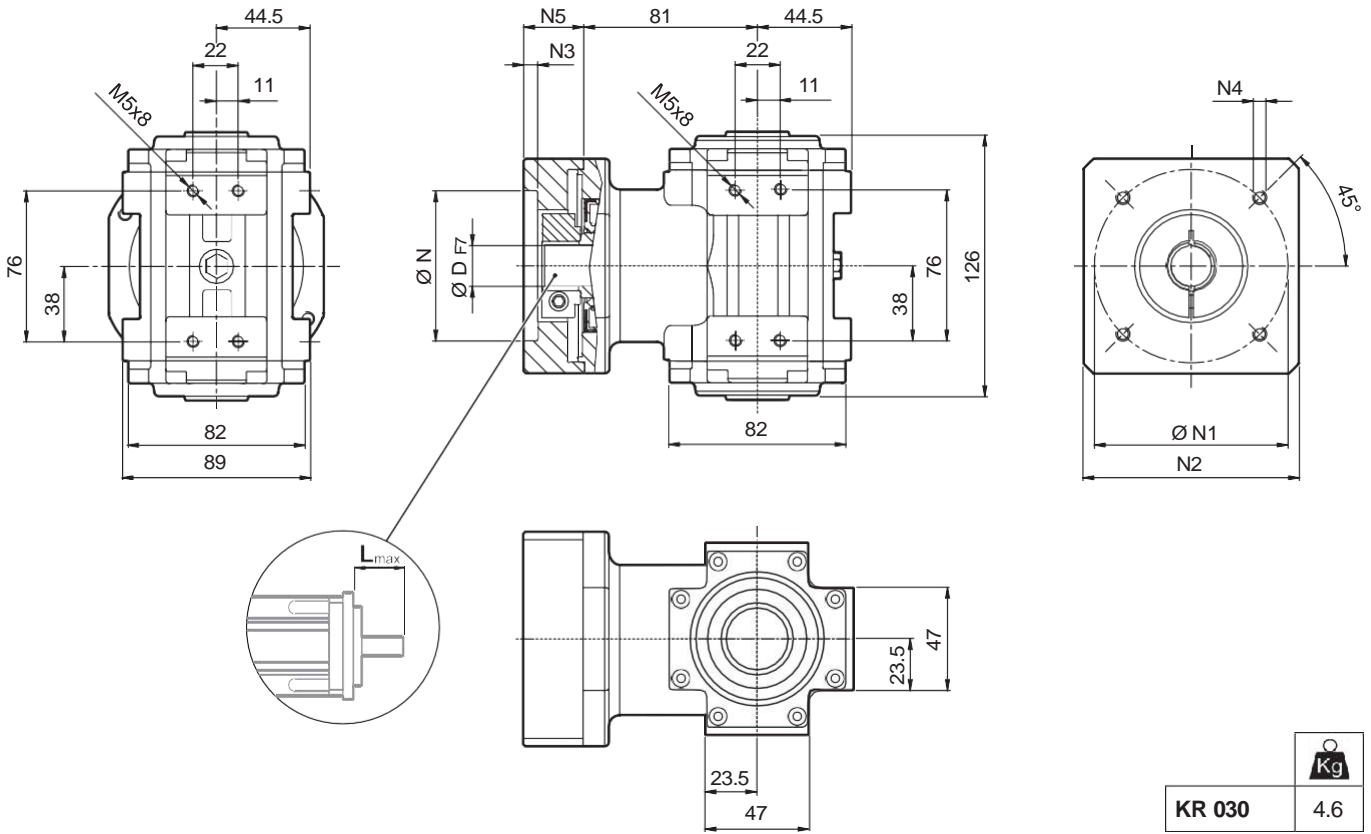

KR 030	4.6

											N	N1	N2	N3	N4	N5	L _{max}
50D	11	12	12.7	14	15	15.875	16	19	-	-	50	95	100	5	M6x14	28	40
55A	11	12	12.7	14	15	15.875	16	19	-	-	55.5	125.7	105	5	M6x16	28	40
60A2	11	12	12.7	14	15	15.875	16	19	-	-	60	75	100	5	M5x14	28	40
60AH2	11	12	12.7	14	15	15.875	16	19	-	-	60	75	100	5	6.5	33	40
60B1	11	12	12.7	14	15	15.875	16	19	-	-	60	85	100	6.5	M5x14	28	40
70A1	11	12	12.7	14	15	15.875	16	19	-	-	70	85	100	5	M6x14	28	40
70AH1	11	12	12.7	14	15	15.875	16	19	-	-	70	85	100	5	6	33	40
70B1	11	12	12.7	14	15	15.875	16	19	-	-	70	90	100	6.5	M5x12	28	40
80A1	11	12	12.7	14	15	15.875	16	19	-	-	80	100	100	5	M6x16	28	40
80AH1	11	12	12.7	14	15	15.875	16	19	-	-	80	100	100	5	6.5	28	40
95A	11	12	12.7	14	15	15.875	16	19	-	-	95	115	100	5	M8x18	28	40
95A1	11	12	12.7	14	15	15.875	16	19	22	24	95	115	100	5	M8x18	38	50
95B	11	12	12.7	14	15	15.875	16	19	-	-	95	130	115	5	M8x18	28	40
110A	11	12	12.7	14	15	15.875	16	19	-	-	110	130	115	5	M8x18	28	40
110A1	11	12	12.7	14	15	15.875	16	19	22	24	110	130	115	6.5	M8x20	38	50
110B	11	12	12.7	14	15	15.875	16	19	22	24	110	145	120	6.5	M8x20	38	50
110B1	11	12	12.7	14	15	15.875	16	19	22	24	110	145	120	6.5	M8x20	48	60
130A	11	12	12.7	14	15	15.875	16	19	22	24	130	165	140	6.5	M10x20	38	50
130A1	11	12	12.7	14	15	15.875	16	19	22	24	130	165	140	6.5	M10x25	48	60

Please contact us for different motor adapters and input shaft bore.

KR 030

KR 030... H

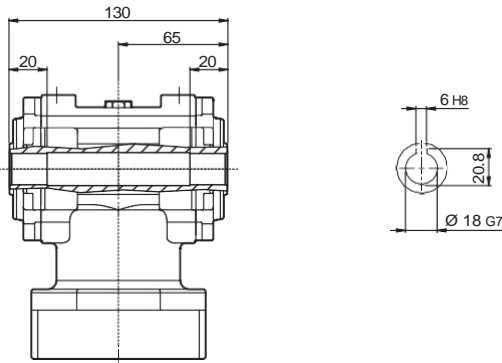

KR 030... HF

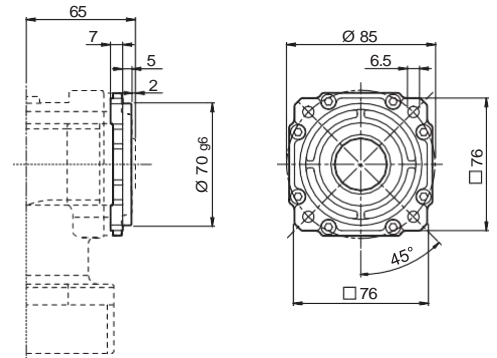

KR 030... S

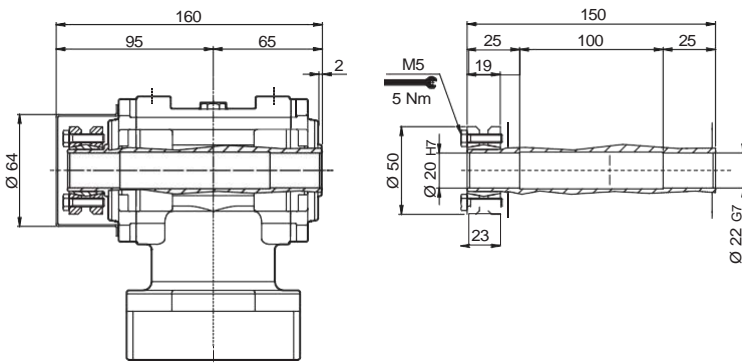

KR 030... SF

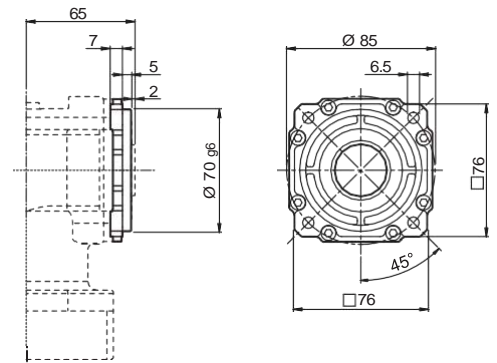

KR 030... LP

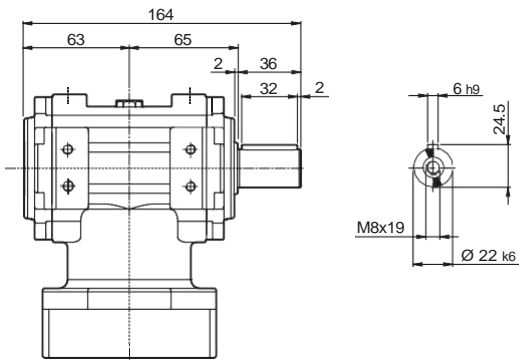

KR 030... LPF

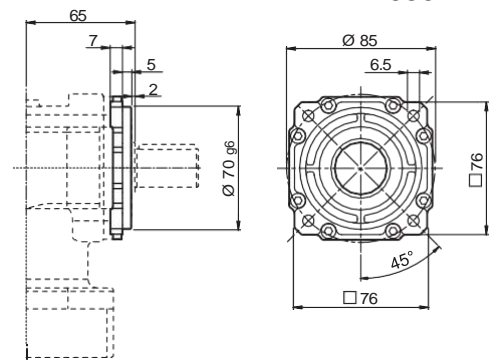

KR 030... LD

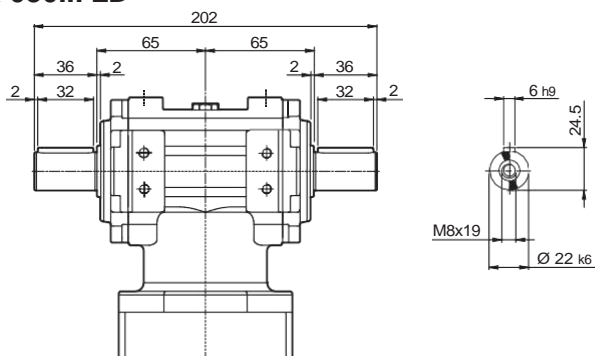

KR 030... LDF

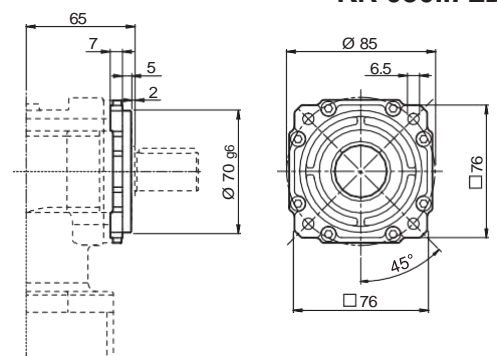

55A1 ... 180A1

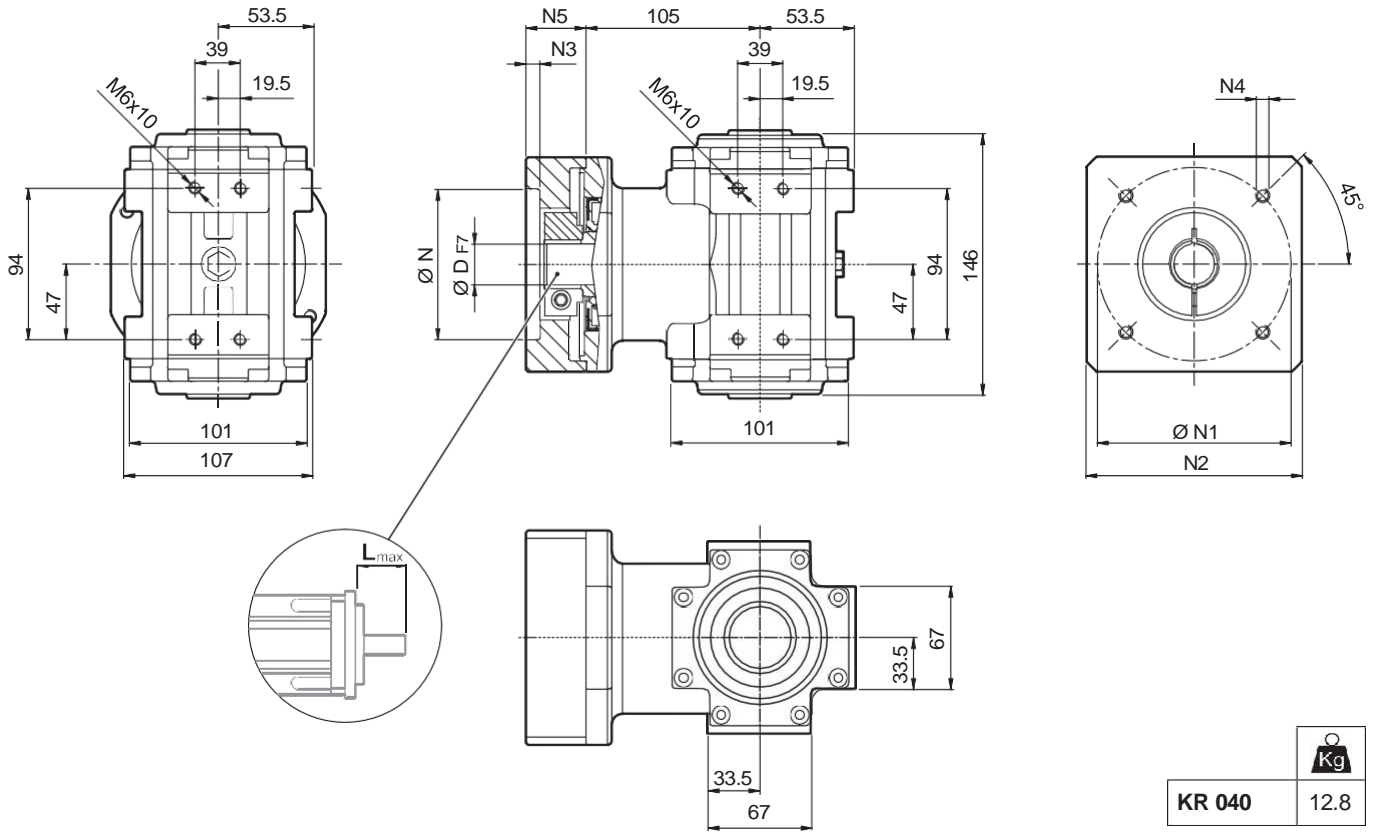

KR 040 12.8

									N	N1	N2	N3	N4	N5	L _{max}
	D														
55A1	14	15.875	16	19	-	-	-	55.5	125.7	130	4	M6x15	39.5	50	
80A2	14	15.875	16	19	-	-	-	80	100	130	4	M6x15	39.5	50	
95A1	14	15.875	16	19	22	24	-	95	115	130	4	M8x20	39.5	50	
110A1	14	15.875	16	19	22	24	-	110	130	130	4	M8x20	39.5	50	
110B1	14	15.875	16	19	22	24	-	110	145	130	6.5	M8x20	49.5	60	
114A	14	15.875	16	19	22	24	28	114.3	200	170	5.5	M12x25	69.5	80	
130A	14	15.875	16	19	22	24	-	130	165	140	4	M10x20	39.5	50	
130A1	14	15.875	16	19	22	24	28	130	165	140	4	M10x20	49.5	60	
180A	14	15.875	16	19	22	24	28	180	215	190	5.5	M14x25	49.5	60	
180A1	14	15.875	16	19	22	24	28	180	215	190	5.5	M14x25	69.5	80	

Please contact us for different motor adapters and input shaft bore.

KR 040

KR 040... H

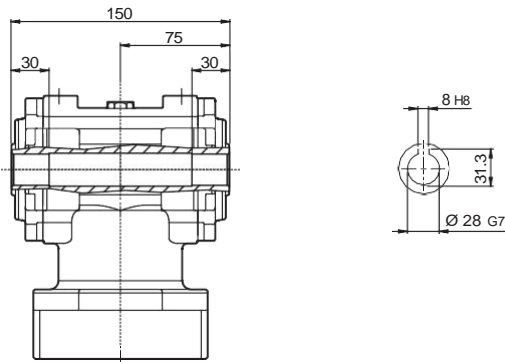

KR 040... HF

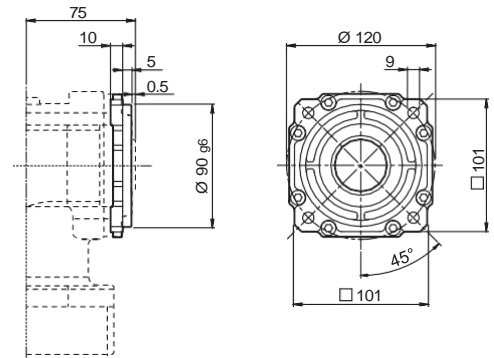

KR 040... S

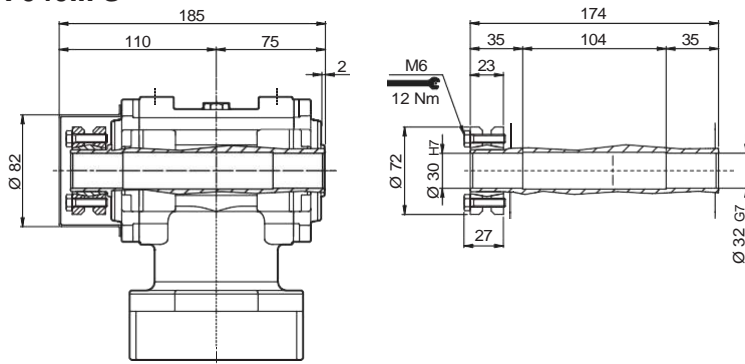

KR 040... SF

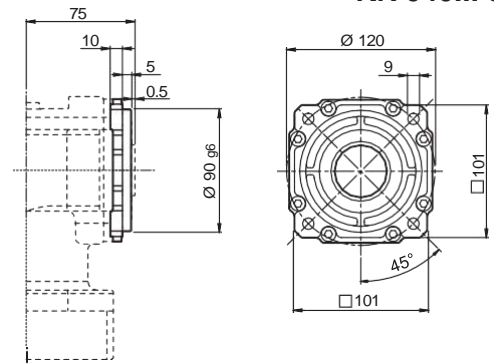

KR 040... LP

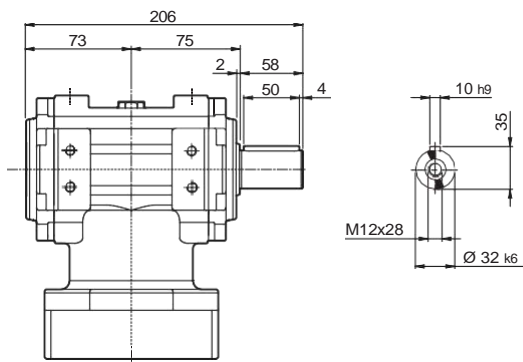

KR 040... LPF

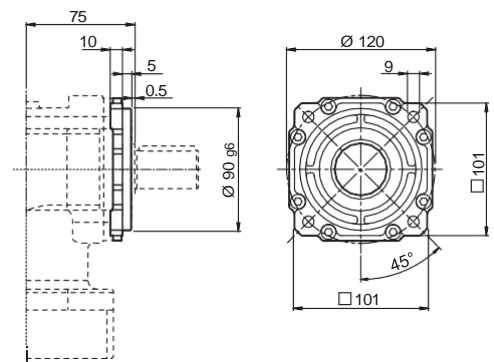

KR 040... LD

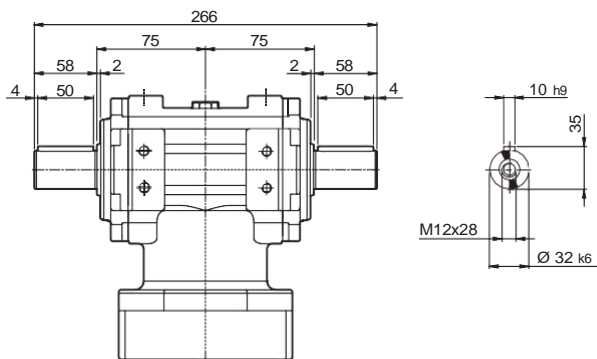

KR 040... LDF

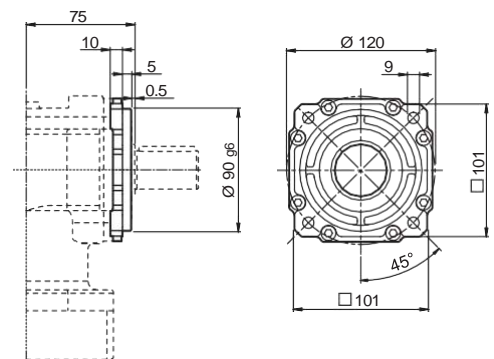

14.7.1 GEARBOX WITHOUT MOTOR ADAPTER

FM

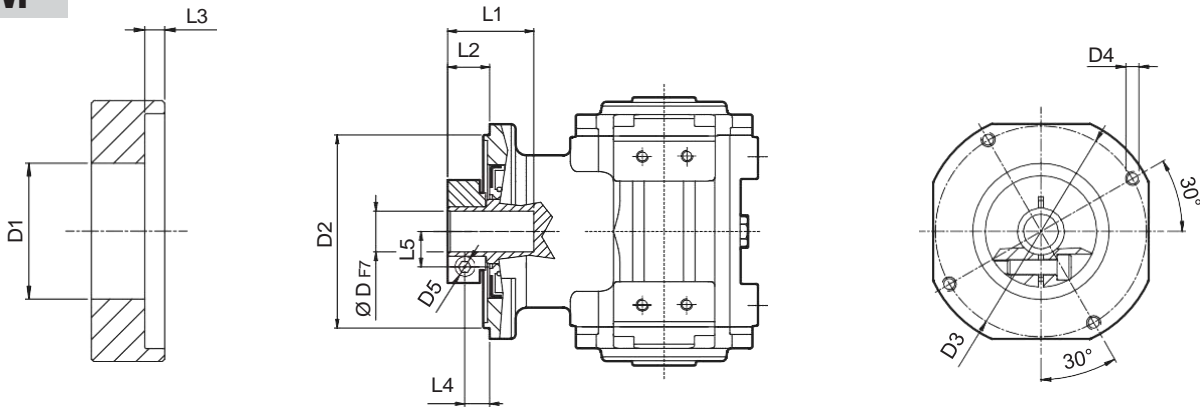

		D1	D2	D3	D4	D5	L1	L2	L3	L4	L5	
KR 010	6 6.35 7	32.5	50	42.5	M4x8	M4	28	13.5	3	8.5	8	1.0
	8 9 9.52 10	32.5	50	42.5	M4x8	M4	28	13.5	3	8.5	9	
	11 12 12.7	35.5	50	42.5	M4x8	M4	23	13.5	3	8.5	11	
	14	35.5	50	42.5	M4x8	M4	25	15.5	3	8.9	11.5	
KR 020	8 9 9.52	38	68	76.5	M6x10	M6	36.3	26.3	9.5	18.8	10.5	2.0
	11 12 12.7	43	68	76.5	M6x10	M6	36.3	26.3	9.5	18.8	12.5	
	14 15.875 16 17	48	68	76.5	M6x10	M6	36.3	26.3	9.5	18.8	14.5	
	19 19.05	51	68	76.5	M6x10	M6	36.3	26.3	9.5	18.8	16.5	
KR 030	11 12 12.7	43	90	98	M6x15	M6	35	19.5	7.6	12.1	12.5	3.5
	14 15 15.875 16	48	90	98	M6x15	M6	35	19.5	7.6	12.1	14.5	
	19	51	90	98	M6x15	M6	35	19.5	7.6	12.1	16.5	
	22 24	56.5	90	98	M6x15	M6	37	21.5	7.6	12.1	19	
KR 040	14 15.875 16	48	113	125.5	M8x15	M6	46	27.5	6	20	14.5	10.0
	19	51	113	125.5	M8x15	M6	46	27.5	6	20	16.5	
	22 24	56.5	113	125.5	M8x15	M6	47.5	29	6	20	19	
	28	67	113	125.5	M8x15	M8	47.5	29	6	20	22.5	

14.7.2 MACHINE SHAFT

Shaft of driven equipment should be made from high grade alloy steel. Table below shows recommended dimensions for the Customer to consider when designing mating shaft. A device retaining the shaft axially is also recommended (not shown). The number and size of relative tapped holes at shaft end depend on application requirements.

H

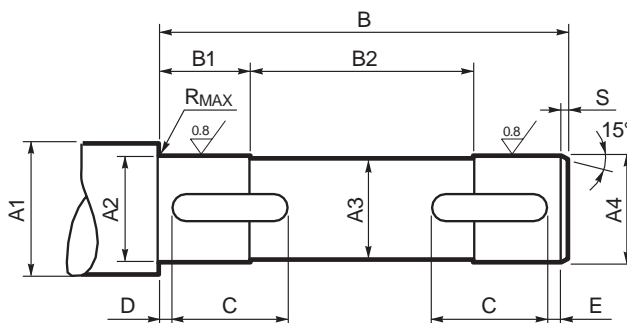

	A1	A2	A3	A4	B	B1	B2	C	D	E	R _{MAX}	 UNI 6604	S
KR 030	≥ 26	18 h7	17	18 h7	129	18	90	32	2	2	0.5	6x6x25 A	1
KR 040	≥ 36	28 h7	27	28 h7	149	28	90	50	2	2	0.5	8x7x35 A	1

NB: The choice of driven shaft with a UNI 6604 key as described introduces increased backlash into the application compared to that achieved by a configuration with just the gearbox ($\phi_s \leq 8^\circ$).

S

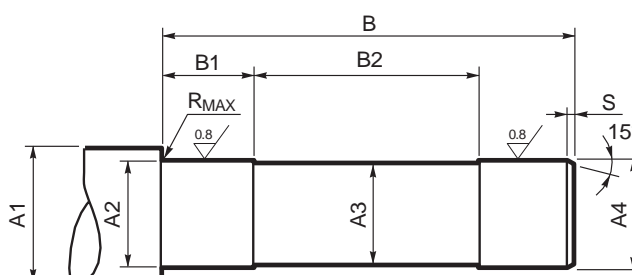

	A1	A2	A3	A4	B	B1	B2	R _{MAX}	S
KR 010	≥ 15	11 h7	9.5	10 h6	99	13	70	0.5	1
KR 020	≥ 20	16 h7	14.5	15 h6	122	18	83	0.2	
KR 030	≥ 30	22 h7	19.5	20 h6	149	23	100	0.5	
KR 040	≥ 40	32 h7	29.5	30 h6	173	33	104	0.5	

KR

INDEX OF REVISIONS

	TI_CAT_TIR_STD_ENG_R06_0
	Description
...	Amended some data.



CMZ reserves the right to change the data in order to update or improve its products without prior notice
CMZ si riserva il diritto di modificare i dati per aggiornare o migliorare i propri prodotti senza alcun preavviso

soga  energyteam

CMZ SISTEMI ELETTRONICI SRL

Via dell'Artigianato 21
31050 Vascon di Carbonera (TV)
Italy
Phone +39 0422 447411
Email cmz@cmz.it

cmz.it