

the other side of motion control

APPLICATIONS CATALOGUE

OUR EXPERTISE
TURNED INTO AN APPLICATION

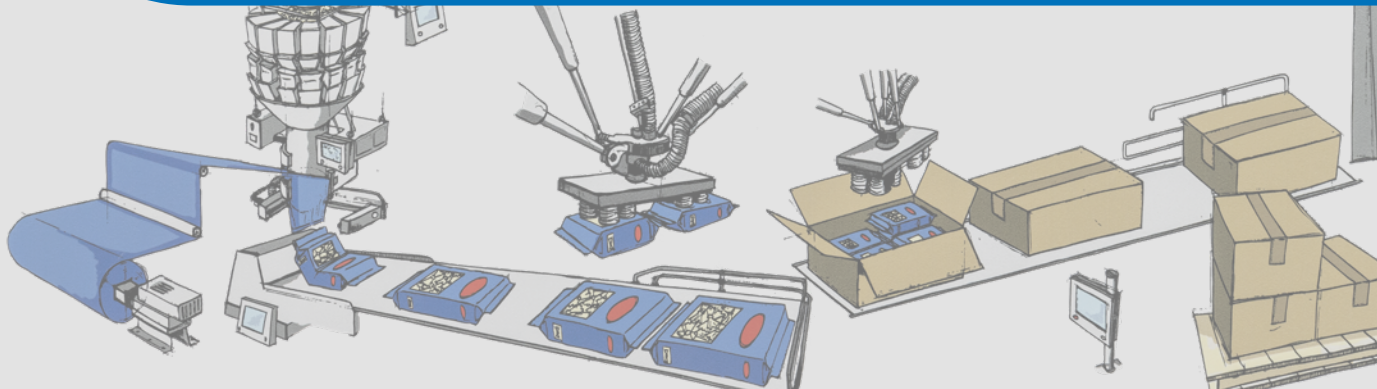
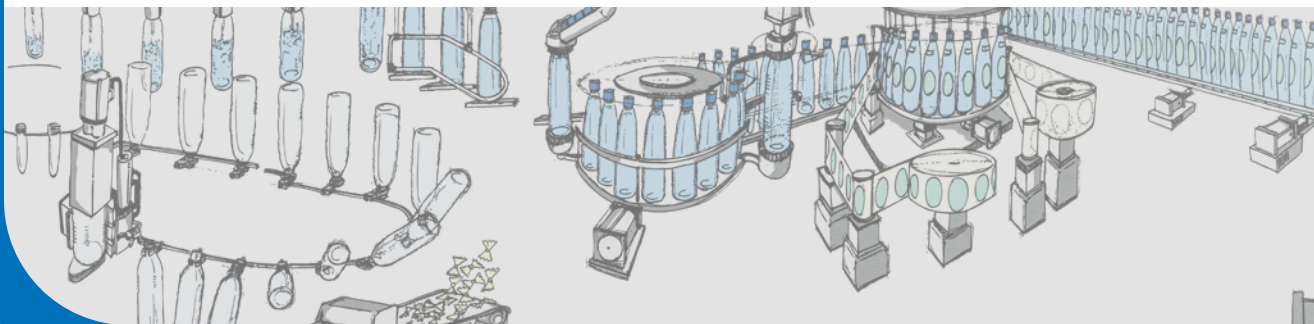

Hardware
Software
Service

MADE IN ITALY

CODESYS







MOTION CONTROL ENGINEERING & PRODUCTION

CMZ SISTEMI ELETTRONICI engineers, produces in Italy and distributes worldwide electronic systems for industrial motion control.

We target to machine builders and systems integrators for the co-development of automatic machines and equipment with customized and specific configurations in multi-axis motion.

Established in 1976 focusing on the production of controllers & drives, today the company offers customizable motion & control solutions including the systems design, the electronics programming, the development of ready-to-use motion & application libraries and ad-hoc softwares, alongside with a wide selection of controllers IEC61131 up to 99 axis, servo drives, brushless and stepper servo motors up to 120 Nm strictly compact and Made in Italy, peripherals and I/O modules both digital and analogic, HMI operator panels.

Our high technological and safety standing is based on a team of 70 technicians and engineers. The systems realized to date in our factory count over 150,000 units.

The company is part of Soga Energy Team industrial group operating in power generation, motion and control and established in 1966.



CMZ Video



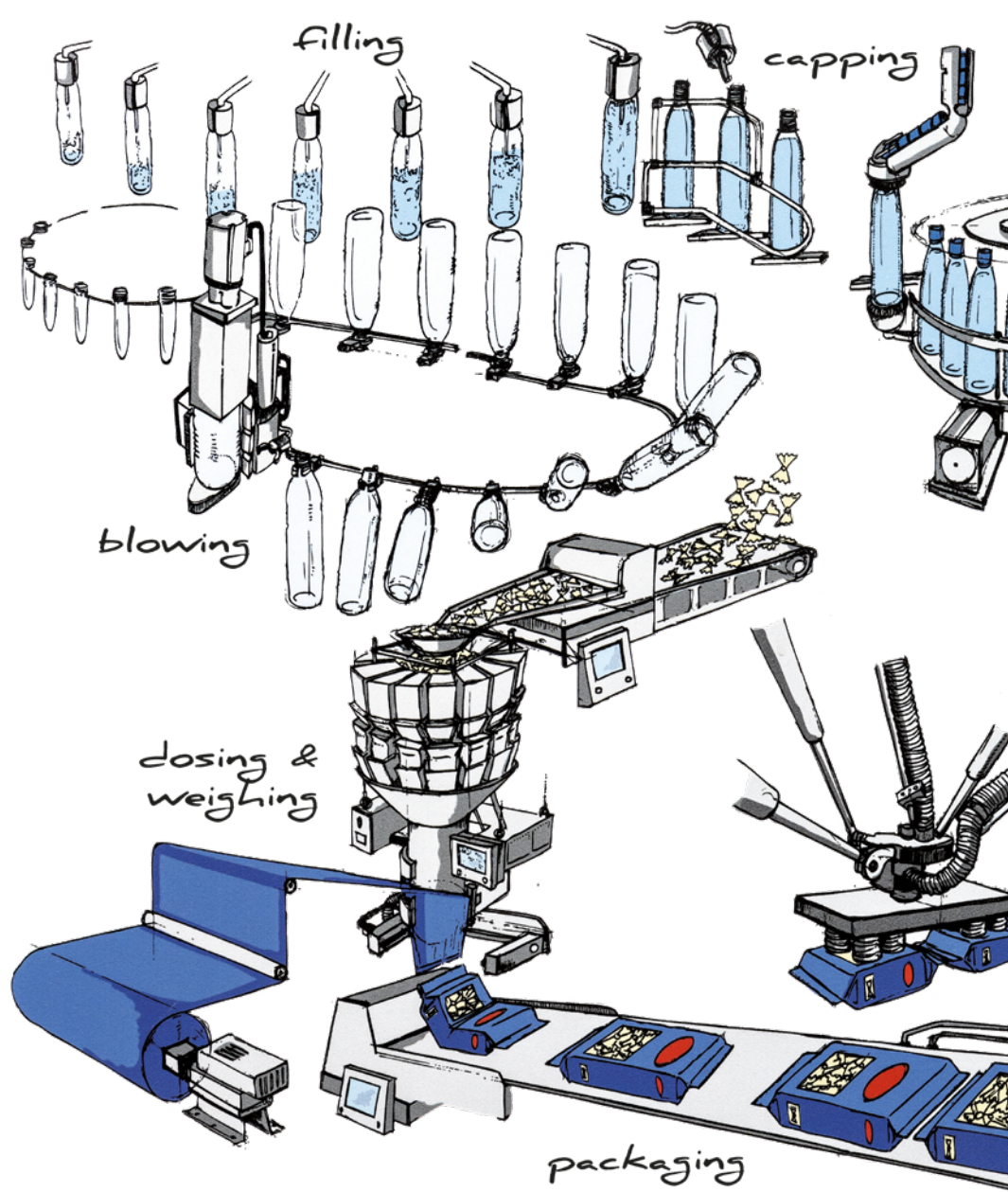

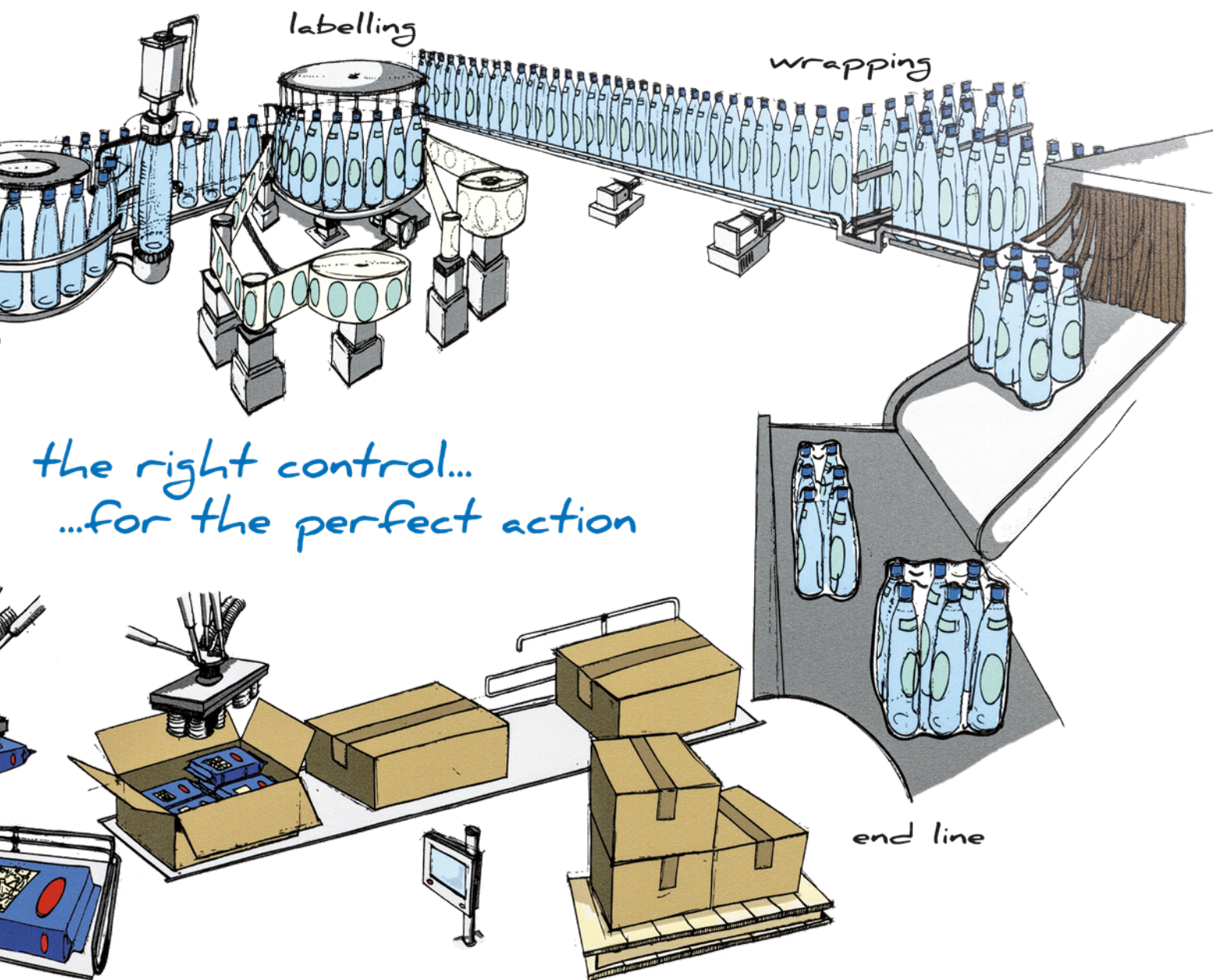

INDEX

Industry 4.0	6
Horizontal Form Fill Seal (HFFS)	8
Vertical Form Fill Seal (VFFS)	12
Multihead Weigher	16
Linear Weigher	20
Self-Adhesive and Roll-Fed Labelling Machines	24

Industry 4.0



For Industry 4.0, comprehensive documentation is provided regarding the application's compliance with regulatory requirements.

The following connection options to IT systems for data exchange in various formats are available:

- Modbus TCP/IP
- FTP server: for file export or import
- OPC-UA with gateway (optional)
- UDP with Client and Server functionality for automated integration (optional), with real-time features.

CMZ_DataConnection is available, a tool installed on a PC for monitoring and recording machine data, with the following functions:

- Interface one or more machines to the management system (MES, ERP, etc.)
- Save data to a MySQL database
- Read/write parameters from/to the controller
- Upload/download files to/from the controller

The tool connects the machine network to the company network, acting as a data collector for integration into the company IT systems.



The following features are available:

- Batch production management
- Remote recipe selection
- Setting production speed, communication monitoring, and others
- Log with buffering of downloaded weights
- Remote assistance:
 - VNC to remote the HMI interface
 - Router device or router integrated into the HMI panel to connect remotely to the system with development environments for debugging and updating.

Horizontal Form Fill Seal (HFFS)

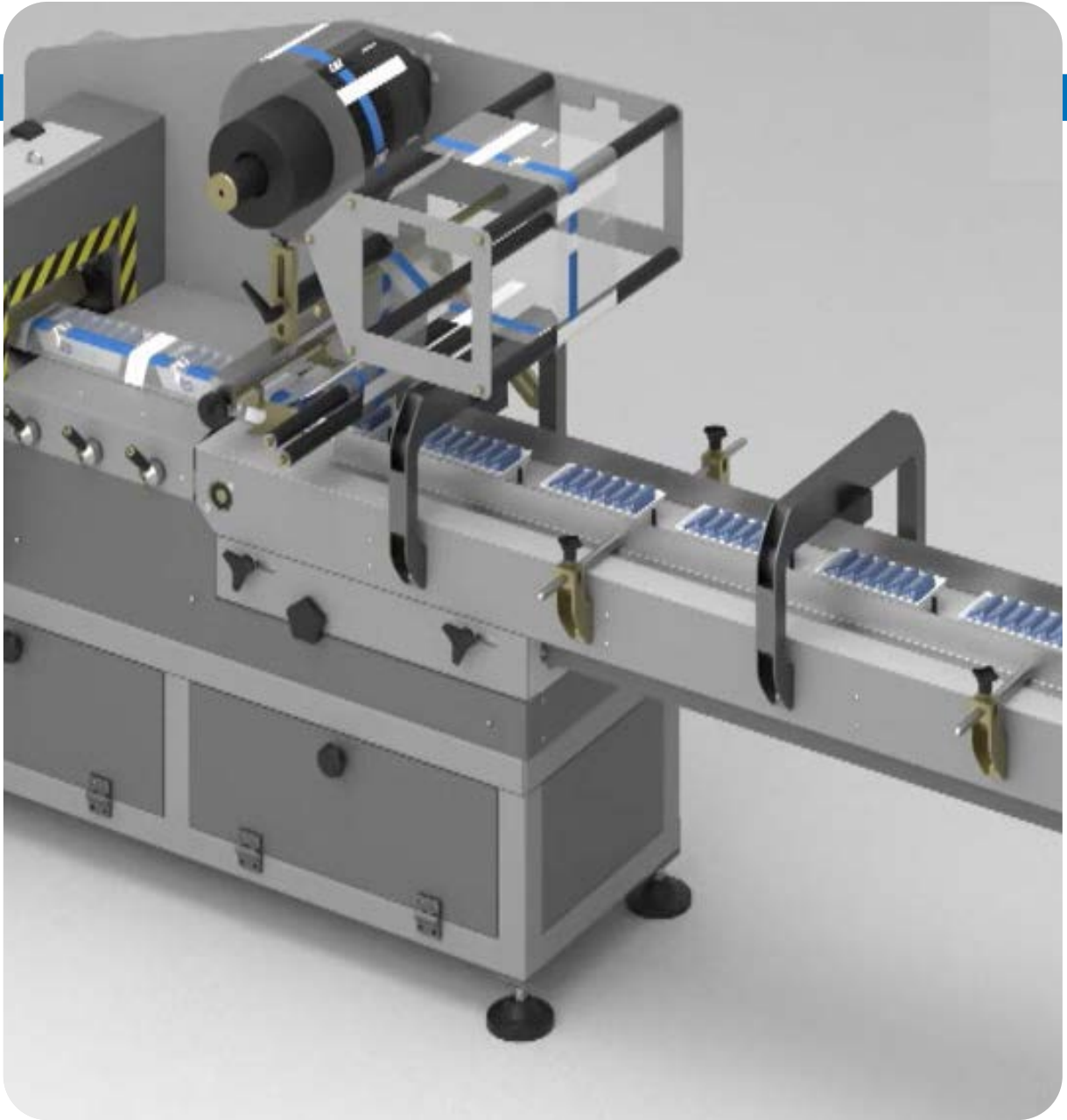

CMZ OFFERS A COMPLETE SOLUTION FOR THE MANAGEMENT OF THE HORIZONTAL PACKAGING MACHINE.

This machine performs the following operations with continuous motion:

- Package formation
- Product insertion
- Longitudinal sealing
- Transverse sealing

The entire process takes place horizontally, ensuring an efficient and automated production flow.

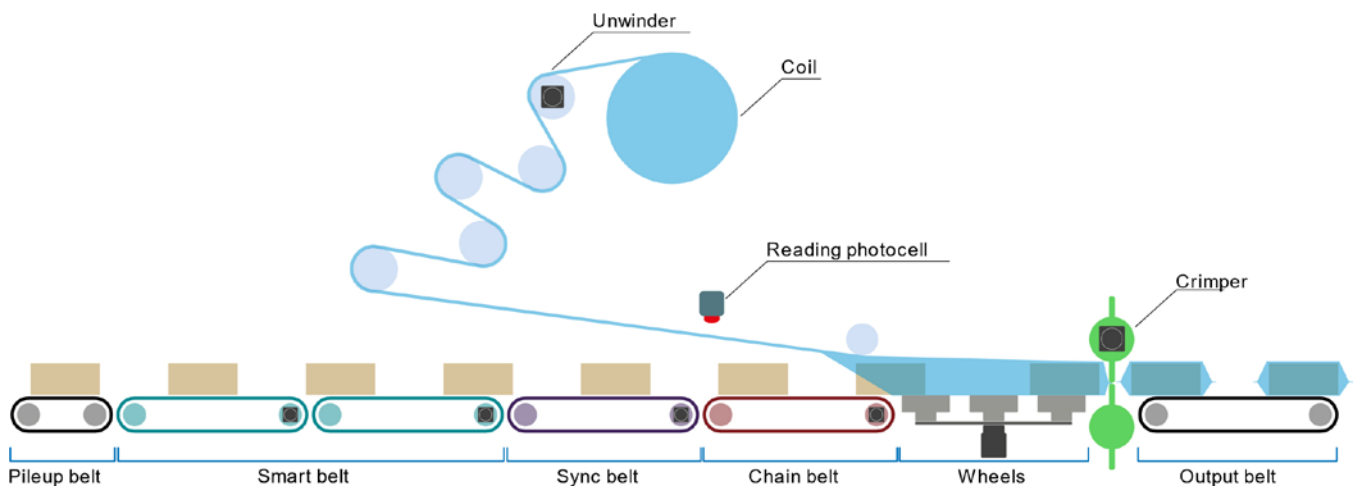

APPLICATION VERSIONS

The horizontal packaging machine is available in the following versions:

- **BASIC:** up to 4 synchronized axes
- **PLUS:** up to 8 synchronized axes
- **HIGH DYNAMIC:** with more than 8 synchronized axes
- **SLIM:** the HFFS Slim is a version with reduced functionalities compared to the HFFS. It meets the following market requirements:

- management of machines with 3 axes and reduced functionality/ services/configuration
- software customizable by the customer
- HMI, motors, and drives from third parties
- possibility of AddOns (already developed by CMZ)

DEVICES

CMZ allows the management of different devices of the horizontal packaging machine, categorized as follows:

- Interfaces and signals
- Interface with the upstream machine
- Product feeding system
- Product loading
- Film feeding and package formation
- Package sealing and cutting
- Package unloading
- Interface with the downstream machine
- Temperature regulation
- Acoustic/visual signals

CMZ OFFERING

		Base supply	Optional supply
SW	CODESYS Application	●	
SW	HMI Application	●	
SW	Managing TB20 modules to remote the I/Os	●	
SW	Managing of inverters	●	
SW	Managing of Industry 4.0	●	
SW	Customization to be defined		●
SW	Managing servo drives other than CMZ*		●
SW	Managing motors other than CMZ*		●
SW	Managing HMI other than CMZ*		●
SW	Customization: synchronization tape of the incoming product to the chain		●
SW	Customization: accumulation tapes, with capping function (up to 4 tapes)		●
SW	Customization: product level control for adjusting production speed		●
SW	Customization: auxiliary film pull roller (film feed)		●
SW	Customization: automatic film reel change, with second unwinder management		●
Service	Documentation to modify the software, use the interface and make the wiring diagram	●	
Service	3-day ACADEMY course on: <ul style="list-style-type: none"> • general application • program on FCT • program on HMI • AddOn • commissioning management 	●	
Service	1-day ACADEMY course on devices (if not familiar)		●

		Base supply	Optional supply
HW	Controller: FCT640, FCT641	●	
HW	HMI	●	
HW	Drives SBD M / SBD L / SSD / IBD / ISD e NBD: nr. 3	●	
HW	Brushless motors from CMZ's catalog: nr. 3	●	
HW	TB20 Digital Input Modules: the type and number of modules depend on how many digital inputs are needed	●	
HW	TB20 Digital Output Modules: the type and number of modules depend on how many digital outputs are needed	●	
HW	TB20 IO modules: the type and number of modules depend on how many temperature sensors are needed and their type (thermocouples and/or resistance thermometers)	●	
HW	TB20 Analog Output Modules: the type and number of modules depend on how many analog outputs are needed	●	
HW	Router	●	
HW	TB20 modules to remote I/O: the type and number of modules depends on what and how many I/Os are needed		●
HW	Inverter film unwinder		●
HW	Inverter tape unwinder output		●

*subject to verification by CMZ

Vertical Form Fill Seal (VFFS)



CMZ OFFERS A COMPLETE SOLUTION FOR THE MANAGEMENT OF THE VERTICAL CONTINUOUS CYCLE PACKAGING MACHINE.

This machine performs the following operations with continuous motion:

- Package formation
- Longitudinal sealing
- Transverse sealing

The entire process takes place vertically, ensuring an efficient and automated production flow without any interruption in movement.

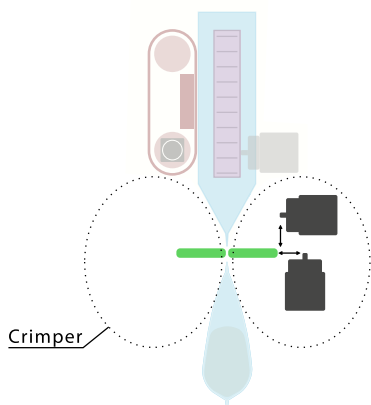
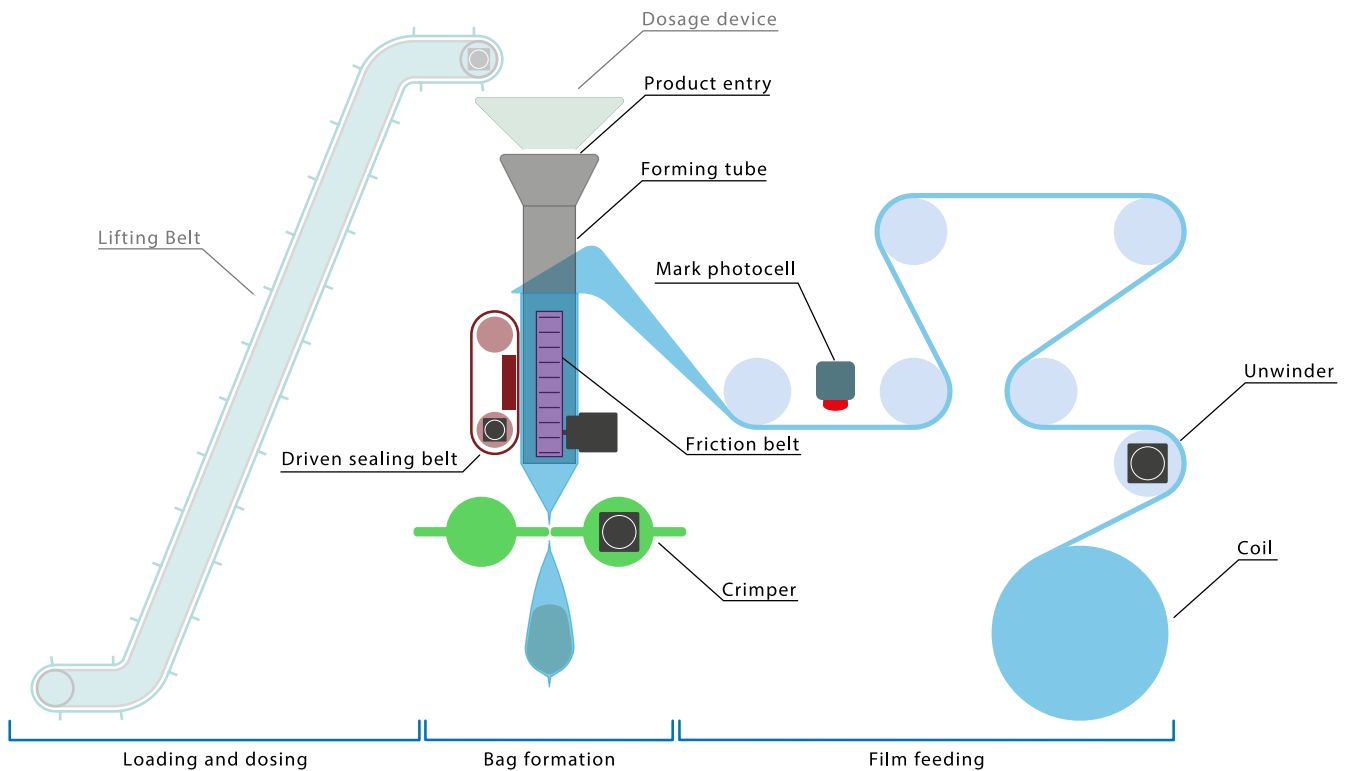

The crimper can be made with 1 motor or 2 motors. On the side is a representation with 2 motors.

MACHINE ZONES

The application includes the management of the different operational zones of the packaging machine:

- Loading and dosing
- Film feeding: reel unwinding and centering
- Forming tube: film pulling and longitudinal sealing
- Package sealing and cutting
- Package unwinding

DEVICES

- Interfaces and signals
- Interface with the upstream machine
- Loading and Dosing
- Film Feeding
- Forming Tube
- Package Sealing and Cutting
- Package Unloading
- Interface with the downstream machine
- Temperature regulation
- Acoustic and Visual Signals

CMZ OFFERING

		Base supply	Optional supply
SW	CODESYS Application	●	
SW	HMI Application with italian and english language	●	
SW	HMI operator interface manual (Italian/English)	●	
SW	HMI with other languages		●
SW	HMI of the client		●
SW	CMZ inverter management	●	
SW	Industry 4.0 management	●	
SW	Customizations (to be agreed)		●
SW	Managing of drives other than CMZ*		●
SW	Managing of motors other than CMZ*		●
SW	Third-party device management		●
SW	Dispenser management		●
SW	Automatic film reel change, with second unwinder management		●
Service	Initiating work to gather needs and share the CMZ proposal	●	
Service	<ul style="list-style-type: none"> • Wiring Diagram of managed devices • Sharing manuals 	●	
Service	Customer logo customization on HMI	●	
Service	1-day ACADEMY course for: <ul style="list-style-type: none"> • configuration from HMI • production startup 	●	
Service	2-day support for: <ul style="list-style-type: none"> • supporting the machine wiring diagram • supporting the installation of the supplied devices • commissioning the machine 	●	
Service	1-day ACADEMY course for the use of devices (if not familiar)		●
Service	1-day ACADEMY course for configuration and production startup	●	
Service	After-sales service on a consensus basis		●

		Base supply	Optional supply
HW	Controller: FCT640, FCT641	●	
HW	TB20 Digital Input Modules: the type and number of modules depend on the needs	●	
HW	TB20 Digital Output Modules: the type and number of modules depend on the needs	●	
HW	TB20 Input temperature modules: the type and number of modules depend on how many temperature sensors are needed and their type (thermocouples and/or resistance thermometers)	●	
HW	TB20 Analog Output Modules: the type and number of modules depend on the needs	●	
HW	HMI	●	
HW	Drives SBD M / SBD L / SSD / IBD / ISD e NBD	●	
HW	Brushless motors from CMZ catalogs	●	
HW	Router	●	
HW	Cables for connecting managed devices	●	
HW	Inverter film unwinder		●
HW	Inverter tape output		●
HW	Rotary table inverter		●

*subject to verification by CMZ

Multihead weigher



CMZ OFFERS A COMPLETE SOLUTION FOR THE MANAGEMENT OF MULTI-HEAD WEIGHERS WITH MOTORIZED BUCKETS USING STEPPER MOTORS.

The system, consisting of the scale, the pre-doser (optional), and the memory bucket (optional), is referred to as a **head**. The number of heads can range from 4 to 32.

A group of heads working together to determine the product's weight is called a **section**, with their number ranging from 1 to 4. The group of sections that feed the downstream packaging machine is called a **unit**. Units range from 1 to 2.

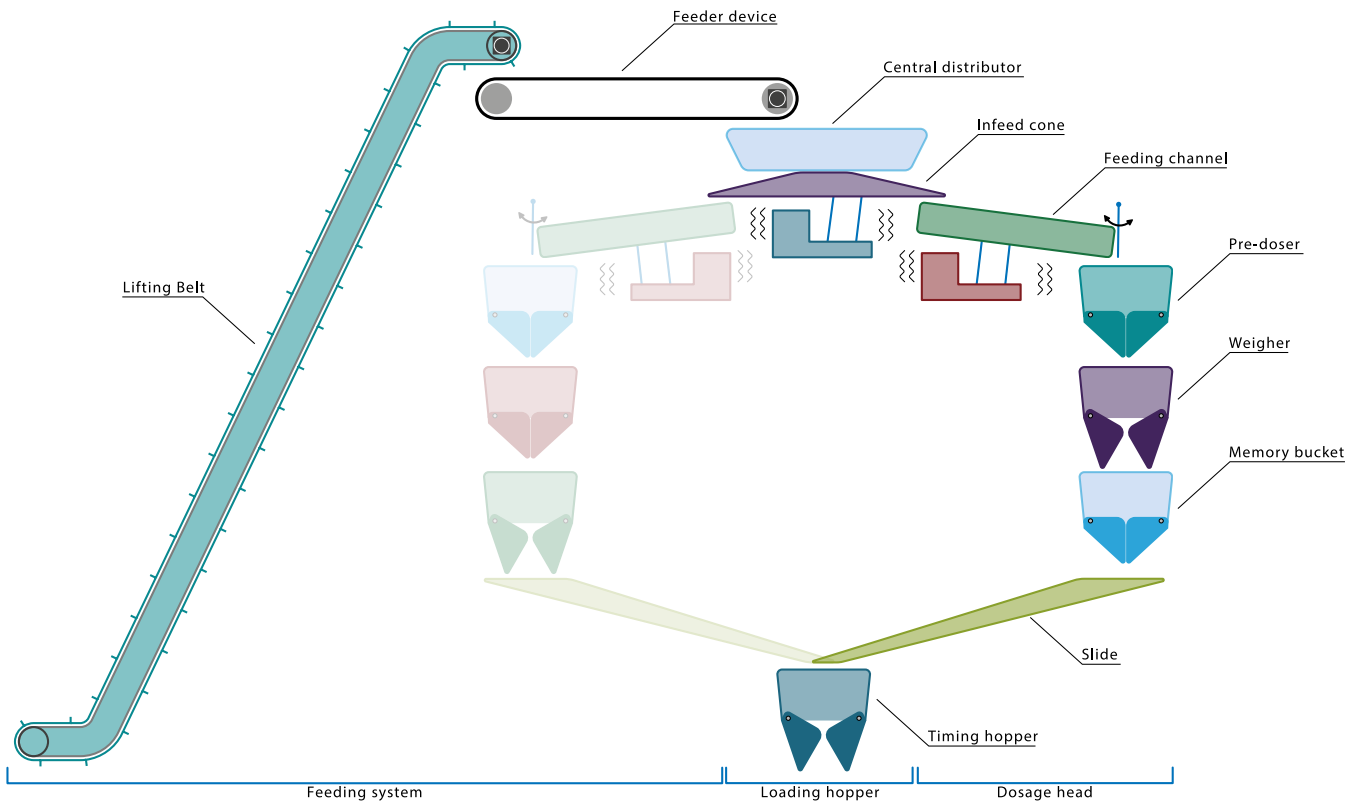











DEVICES

- Interfaces and signals
- Feeding system
- Loading hopper
- Central distributor
- Dosing head
- Refilling system
- Unloading system
- Quality interface and control

FEATURES

- Management of product loading and distribution
- Weighing optimization
- Combination algorithms and bucket management
- Unloading and refilling management
- Configuration of sections and units
- Dosing modes and interfacing
- Maintenance and diagnostics
- Monitoring and safety

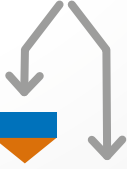
DOSING HEAD CONFIGURATIONS

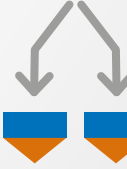
Description	1	2	3	4	Presence
Pre dosing					Optional
Scale					Always present
Memory baskets					Optional

CMZ OFFERING

		Base supply	Optional Supply
SW	CODESYS Application	●	
SW	HMI Application with Italian and English languages	●	
SW	HMI operator interface manual (Italian/English)	●	
SW	HMI with other languages		●
SW	Industry 4.0 management	●	
SW	Customization (to be defined)		●
SW	HMI Panel PC from client		●
SW	Stepper motors of third parties (driven by CPMSG0)		●
SW	Managing of third parties products		●

		Base supply	Optional Supply
Service	Initiating work to gather needs and share the CMZ proposal	●	
Service	<ul style="list-style-type: none"> • Wiring Diagram of managed devices • Sharing manuals 	●	
Service	Customer logo customization on HMI	●	
Service	1-day ACADEMY course for: <ul style="list-style-type: none"> • configuration from HMI • production startup 	●	
Service	3-day support for: <ul style="list-style-type: none"> • supporting the machine wiring diagram • supporting the installation of the supplied devices • commissioning the machine 	●	
Service	1-day ACADEMY course for configuration and production startup	●	
Service	Post-sales assistance		●
HW	Controller: FCT640, FCT641	●	
HW	TB20 Digital Input Modules: the type and number of modules depend on the needs	●	
HW	TB20 Digital Output Modules: the type and number of modules depend on the needs	●	
HW	TB20 Analog Input Modules: the type and number of modules depend on the needs	●	
HW	TB20 Analog Output Modules: the type and number of modules depend on the needs	●	
HW	HMI Panel PC	●	
HW	Drive vibrator: CP4PWM	●	
HW	Basket handling drive and load cell reading: CPMSG0	●	
HW	Basket motors (controlled by CPMSG0)	●	
HW	Router	●	
HW	Cables for connecting managed devices	●	
HW	Loading/unloading belt inverter		●
HW	Inverter rotary central distributor		●

Linear weigher



CMZ OFFERS A COMPLETE SOLUTION FOR THE MANAGEMENT OF LINEAR WEIGHERS.

The system is configurable with **1 to 4 dosing heads**, featuring **pneumatically moved buckets**, with the possibility to perform **rough** and **fine weighing** on a single or double weighing bucket. It is also possible to configure the presence of a **memory bucket**.

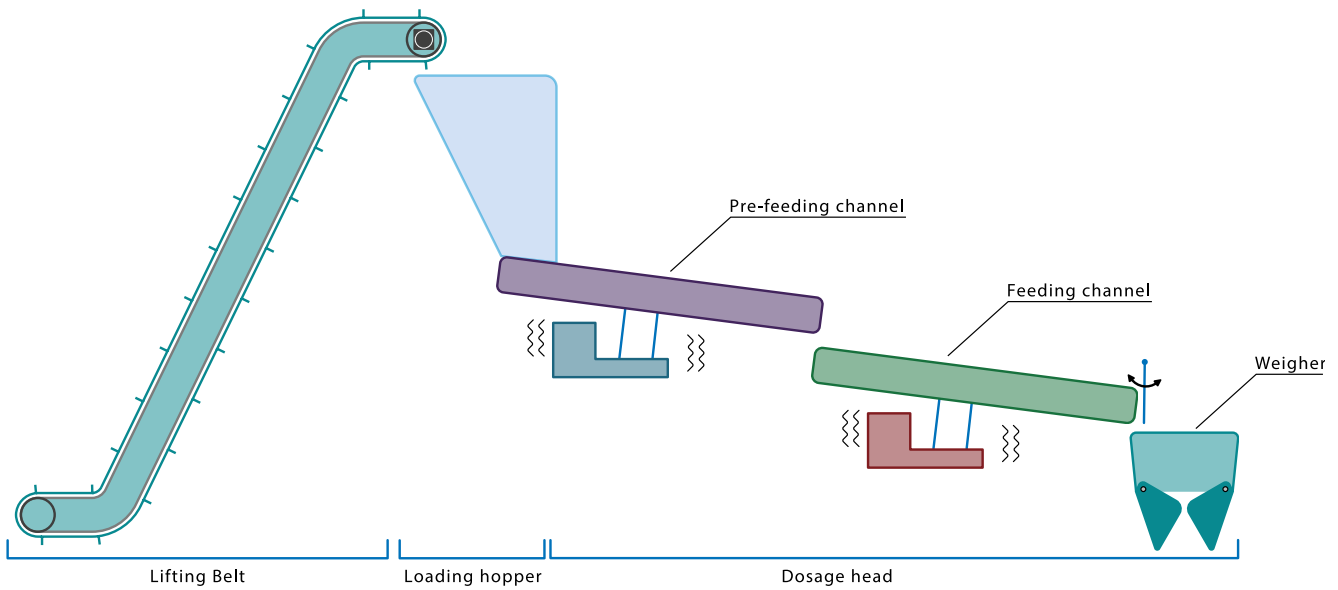



DEVICES

- Interfaces and signals
- Feeding system
- Loading hopper
- Dosing head
- Refilling system
- Quality interface and control

FEATURES

- Weighing optimization
- Dosing modes and interfacing
- Maintenance and diagnostics
- Monitoring and safety

DOSING HEAD CONFIGURATIONS

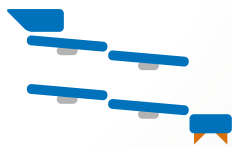
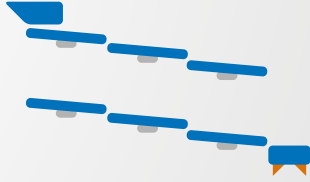
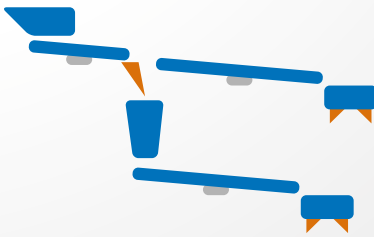
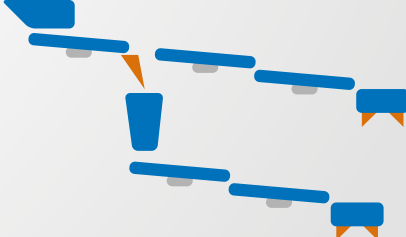
Buckets	Channel	2 levels	3 levels
Single weighing bucket	Single channel		
	Channel of rough and fine weighing		
Double weighing bucket (optional)	Channel of rough and fine weighing		

CMZ OFFERING

		Base supply	Optional supply
SW	CODESYS Application	●	
SW	HMI Application with italian and English languages	●	
SW	HMI operator interface manual (Italian/English)	●	
SW	HMI with other languages		●
SW	HMI of the client		●
SW	Industry 4.0 management	●	
SW	Customization (to be defined)		●
SW	Managing of third parties products		●

		Base supply	Optional supply
Service	Initiating work to gather needs and share the CMZ proposal	●	
Service	<ul style="list-style-type: none"> • Wiring Diagram of managed devices • Sharing manuals 	●	
Service	Customer logo customization on HMI	●	
Service	1-day ACADEMY course for: <ul style="list-style-type: none"> • configuration from HMI • production startup 	●	
Service	2 -day support for: <ul style="list-style-type: none"> • supporting the machine wiring diagram • supporting the installation of the supplied devices • commissioning the machine 	●	
Service	1-day ACADEMY course for configuration and production startup	●	
Service	Post-sales assistance		●
HW	Master Controller: FCT640, FCT641	●	
HW	TB20 Digital Input Modules: the type and number of modules depend on the needs	●	
HW	TB20 Digital Output Modules: the type and number of modules depend on the needs	●	
HW	TB20 Analog Input Modules: the type and number of modules depend on the needs	●	
HW	TB20 Analog Output Modules: the type and number of modules depend on the needs	●	
HW	HMI	●	
HW	Drive vibrator: CP4PWM	●	
HW	Router	●	
HW	Cables for connecting managed devices	●	
HW	Loading/unloading belt inverter		●

Self-Adhesive and Roll-Fed Labelling Machines



White Paper





CMZ HAS DECADES OF EXPERIENCE IN THE LABELLING SECTOR, OFFERING PRODUCTS AND THE APPROPRIATE APPLICATION EXPERTISE FOR MANUFACTURERS OF SELF-ADHESIVE AND ROLL-FED LABELLING MACHINES.

PRODUCTS

For this type of machine, CMZ offers:

- Motors with integrated drive (IBD brushless series and ISD stepper series), particularly suitable for automating devices (plates) on the rotary table and synchronized loading/unloading devices (augers and stars).
 - The integrated motor-drive solution is the ideal choice to achieve the maximum reduction in space and simplified wiring on the table.
 - Brushless drives (SBD series), with the corresponding brushless motors (MMD series) and stepper motors (SSD series) for all machines that allow the installation of the drive in the control panel.
 - The brushless and stepper alternatives offer a choice to combine performance and cost for every type of machine.

- The PLC/Controller CODESYS from the FCT series is the correct choice for managing the application and the movement of the various devices on these machines. The same FCT, thanks to communication protocols (e.g., OPC-UA), allows interfacing with the company supervision systems (INDUSTRY 4.0).
- Embedded panels or PCs can be supplied to complete the machine with the human-machine interface (HMI).
- The optional (but recommended) presence of a ROUTER allows for remote assistance of the machine, regardless of the country where it is installed.

APPLICATIVE

CMZ offers its full expertise in software development for the management of synchronized axis motion (electronic cams and interpolation) and cyclical machine operations.

The experience extends to the development of software for HMI management and machine integration within Industry 4.0.

■ SELF-ADHESIVE LABELLING MACHINES

ROTARY TABLE, LOADING / UNLOADING AND PLATES

Schematic representation of the machine can be shown as:

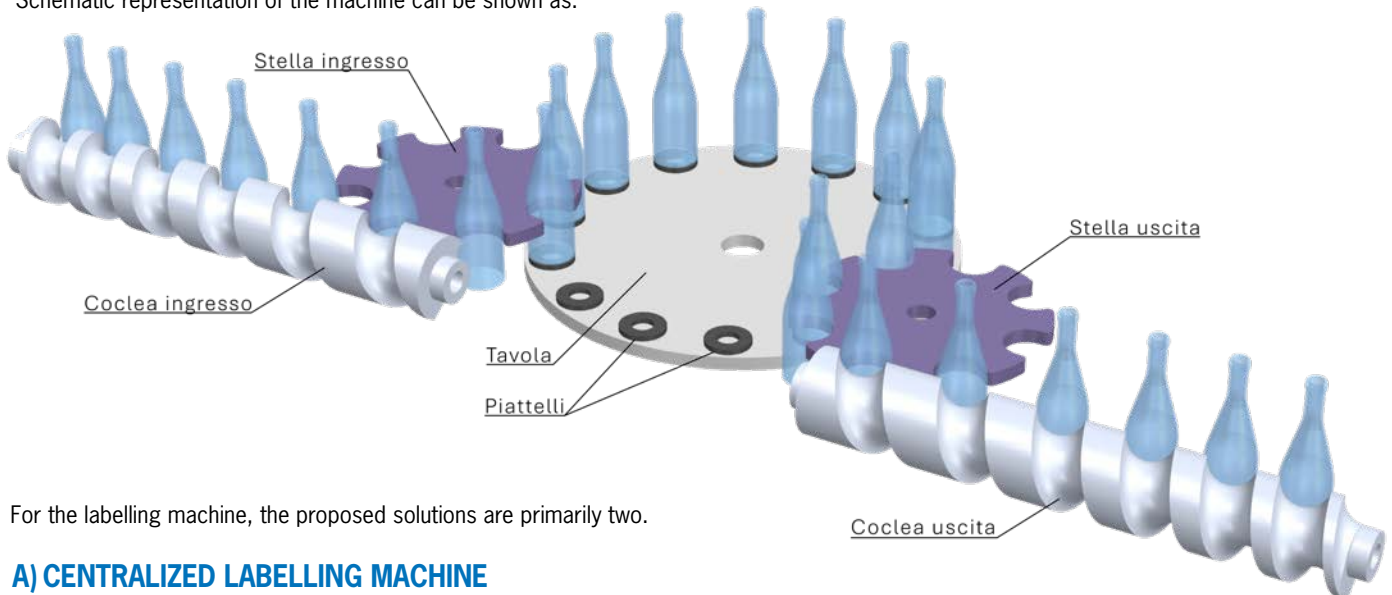

For the labelling machine, the proposed solutions are primarily two.

A) CENTRALIZED LABELLING MACHINE

WITH THIS NAME WE REFER TO A SOLUTION WHERE ALL SYNCHRONIZED MOTION IS HANDLED BY THE PLC / CONTROLLER FROM THE FCT SERIES IN CODESYS.

This is a very flexible solution, entirely implemented within the FCT controller. Thanks to the power of CODESYS, it enables the creation of cyclic operations and synchronization between axes, suitable for any requirement.

For the centralized solution, the use of the FCT controller and the integrated brushless IBD drives in EtherCAT is recommended (a high-performance bus even with a large number of axes).

The power (DC bus) to the plate drives is supplied through the central collector of the table and easily distributed between the plate drives via the daisy chain connection. Similarly, the EtherCAT field bus is distributed through the central collector from the PLC/controller (fixed part) to the drives on the table (mobile part) and facilitated by the presence of the daisy chain connection.

B) DECENTRALIZED LABELLING MACHINE

WITH THIS NAME WE REFER TO A SOLUTION WHERE THE PLC/CONTROLLER MANAGES THE MACHINE CYCLE AND SENDS THE TABLE POSITION TO THE VARIOUS PLATE DRIVES PRESENT ON THE MACHINE.

In this case, the motion of the plates is handled by the drive itself and described within the PLC integrated into the drive.

This solution is less flexible than the previous one, primarily because the motion integrated into the drive is less powerful and flexible.

Synchronization between the table position and the movements of the plates is based on the electronic cam library developed by CMZ, which is suitable for all necessary sequences, such as:

- introduction of the bottle onto the table
- bottle orientation
- labelling stages
- unloading of the bottle

The loading and unloading devices (augers and stars) are also managed by the PLC/Controller in a synchronized manner.

Often in this type of machine, there may also be a supervision PLC. Communication and data exchange between this PLC and the CMZ FCT PLC/controller is guaranteed by the available communication protocols (PROFINET, ETHERNET/IP, and OPCUA).

However, it could be a more cost-effective solution, as it is based on the CANopen field bus and on integrated motor + drive solutions of the stepper type (ISD series).

Again, power supply and CAN bus are brought to the plate drives through the central collector and facilitated by the presence of the daisy chain.

The synchronized motion, related to augers and loading/unloading stars, remains under the direct control of the FCT series PLC/controller.

ADHESIVE GROUPS FOR SELF-ADHESIVE LABELLING MACHINES

THE LABELLING MACHINE DESCRIBED IS COMPLETED WITH THE ADHESIVE GROUPS OUTSIDE THE TABLE.

CMZ also offers solutions for the development of these devices, with more or less complex options for managing the label feeder, the reel unwinder, and the rewinder.

Alternatively, the application program of the Rotary Table will manage the interchanges with third-party adhesive groups.

■ ROLL-FED LABELLING MACHINES

The roll-fed type can also be addressed with the devices and application expertise of CMZ.

The basic machine layout can be represented as follows:

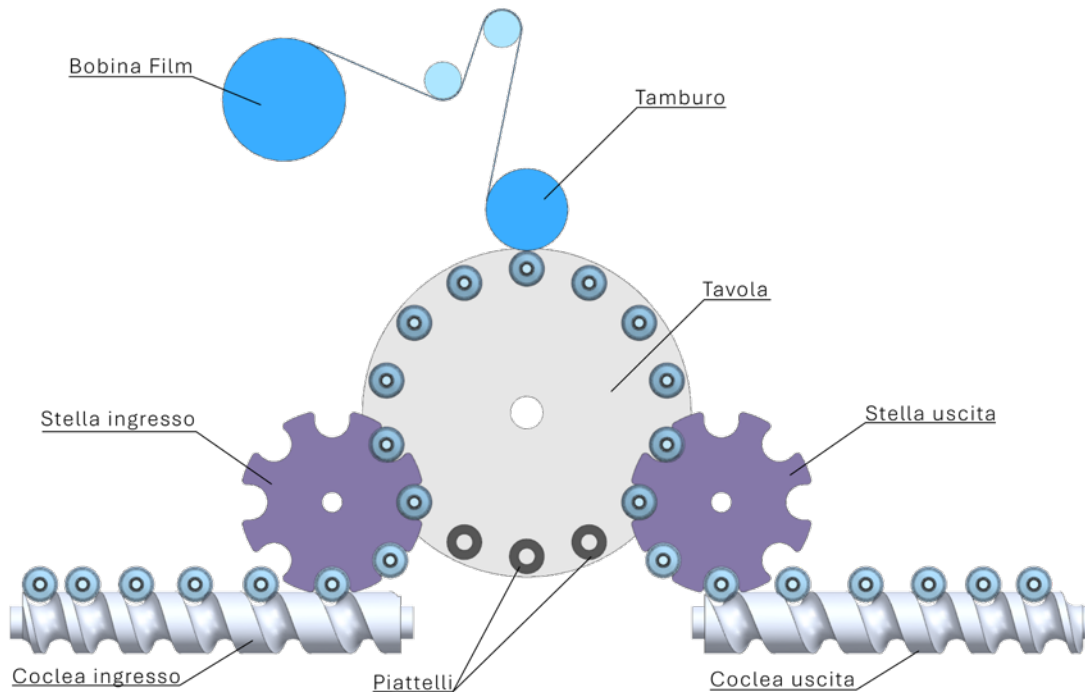

The rotation plates for bottles/jars present on the table/rotary carousel are usually mechanically driven (via pulleys that take motion from the rotation of the table) or by a single motor and a belt system that rotates them all.

Less commonly, individual plate motors are used: in this case, the management of the plates falls under the solution described in the previous application.

Synchronized augers and loading/unloading stars are made with brushless solutions such as the drive from the control panel in the SBD series or the integrated motor and drive solution (IBD series).

The same approach is applied to the reel unwinder (if motorized) and the gluing and film cutting drum.

The best solution in this case is to use an FCT PLC/controller that manages the various brushless drives via EtherCAT.

The controller enables the management of the entire machine cycle and interfacing with company supervision systems (INDUSTRY 4.0).

AUTOMATION PARTNERS

OUR SALES NETWORK IS WORLDWIDE

Be our new automation partner
Contact marketing@cmz.it

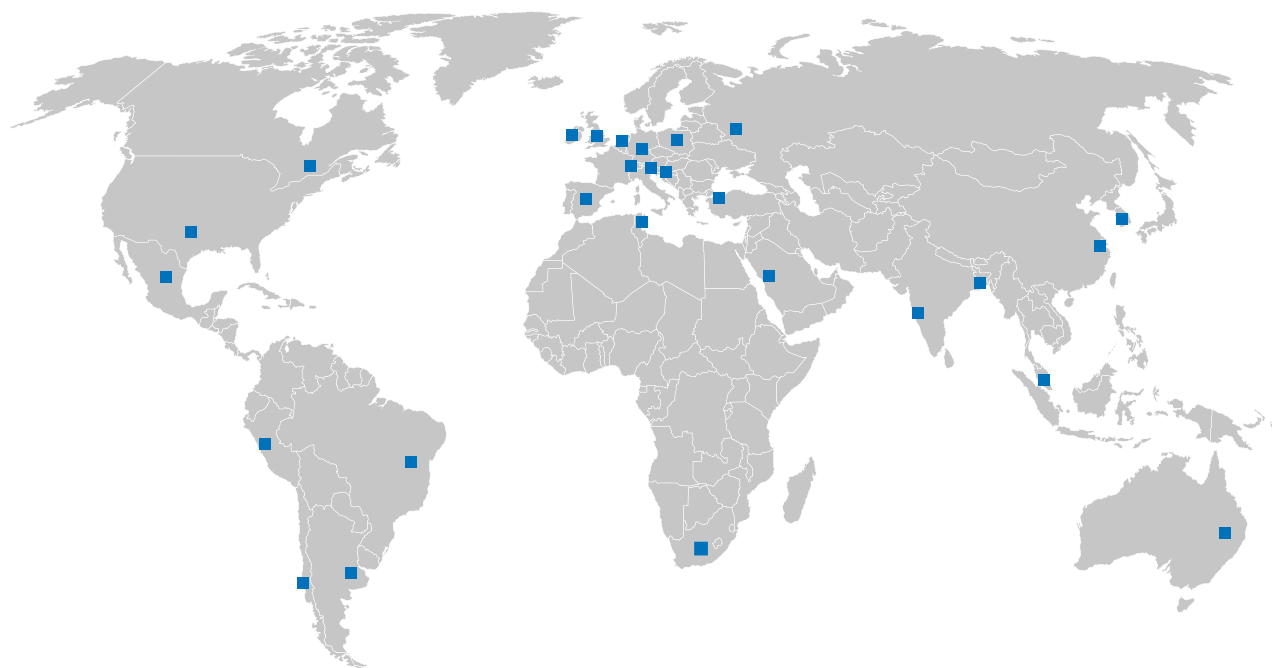

GO TO CMZ
AUTOMATION PARTNERS
ON-LINE



CMZ, A COMPANY OF SOGA ENERGY TEAM



CMZ is part of Soga Energy Team industrial group since 2017.

Soga Energy Team is headquartered in Northern-East Italy in Montecchio Maggiore (Vicenza hinterland) and operates worldwide in 90 countries within power generation, motion & control through 3 companies located in Italy (Soga S.p.A, CMZ Sistemi Elettronici S.r.l) and Croatia (Sincro d.o.o) and 5 brands: SOGA, SINCRIO, AGROWATT, SOGAENERGIES, CMZ.

Owned and managed by the Soga family today in its second generation, the Group develops and manufactures motors, alternators, controllers and drives 100% Made in Europe:

- **Asynchronous electric motors | SOGA**
- **Synchronous & Asynchronous alternators & Rotating welders | SINCRIO**
- **PTO tractor-driven generators | AGROWATT**
- **Permanent magnet, Hybrid and Special generators | SOGAENERGIES**
- **Electronic systems for industrial automation | CMZ**

Besides a range including over 850 standard models of rotating electrical machines among the most diversified and complete in our industry, the Group's portfolio extends to customized executions and the development of new special projects, for creating products with great technical innovative content.

sogaenergyteam.com



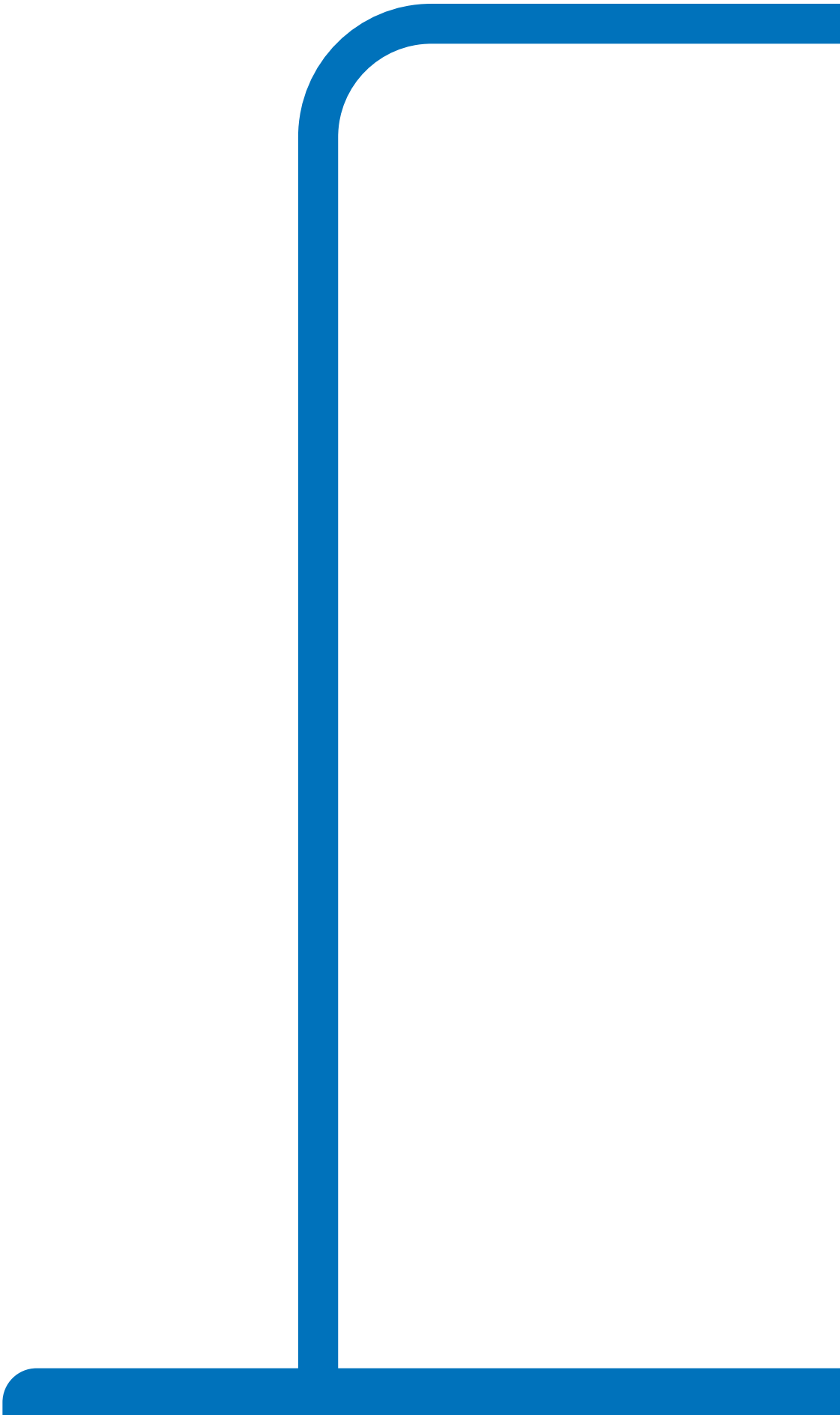



CANopen

EtherCAT

PROFI
NET

CODESYS

ISO 9001
BUREAU VERITAS
Certification



N. 324838

ISO 14001
BUREAU VERITAS
Certification



N. 324839

soga  energyteam

CMZ reserves the right to change the data in order to update or improve its products without prior notice

APPLICATIVES CATALOGUE - April 2025

CMZ SISTEMI ELETTRONICI SRL

Via dell'Artigianato 21
31050 Vascon di Carbonera (TV)
Italy
+39 0422 447411
cmz@cmz.it

cmz.it